



Border Highway (Shared Use Path) Construction Contract Award

November 12, 2024



Project Scope

- The Border Highway West Shared Use Path Project consists of construction of a shared use path from Racetrack to Executive Center Blvd (0.589 miles). The Shared Use Path will run parallel to Border Highway east and serve as a continuation of the existing path.
- The proposed improvements includes:
 - Demolition
 - ADA compliant curb ramps
 - Concrete flume
 - Concrete header curbs and small stem wall
 - Irrigated landscaping with amenities
 - Pavement markings and signs.

This text box is to remind you about the ASL translator service. Do NOT add any info in this space.

REMOVE THIS BOX ONCE THE PRESENTATION IS FINALIZED.

Project Details

This text box is to remind you about the ASL translator service. Do NOT add any info in this space.

REMOVE THIS BOX ONCE THE PRESENTATION IS FINALIZED.

Location:	Border Highway Shared Use Path
District(s):	8
Total Budget:	\$989,526.81
Funding Source:	Federal Participation - TxDOT (94%) Local Government Participation - City of El Paso (6%)

Proposed Cross Section

This text box is to remind you about the ASL translator service. Do NOT add any info in this space.

REMOVE THIS BOX ONCE THE PRESENTATION IS FINALIZED.

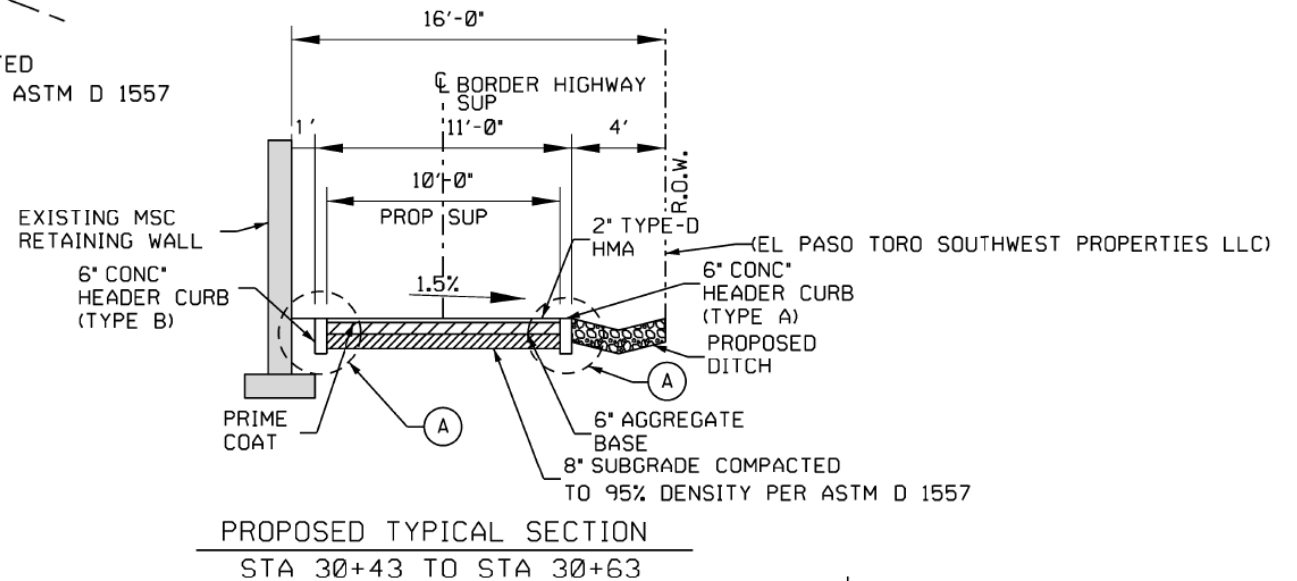
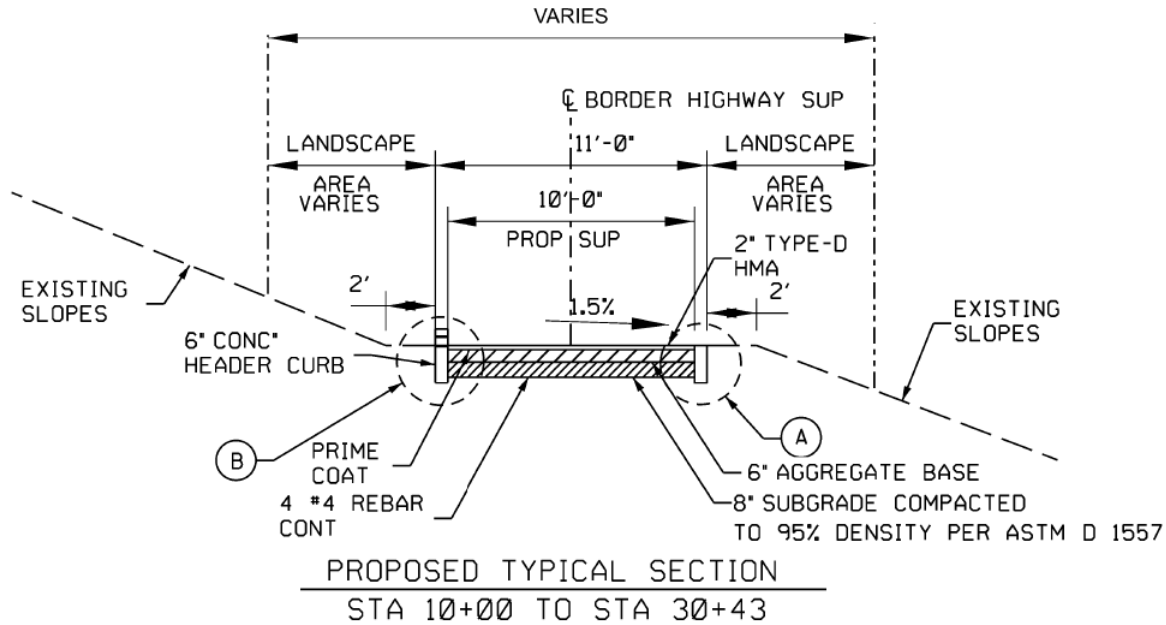

Proposed Cross Section

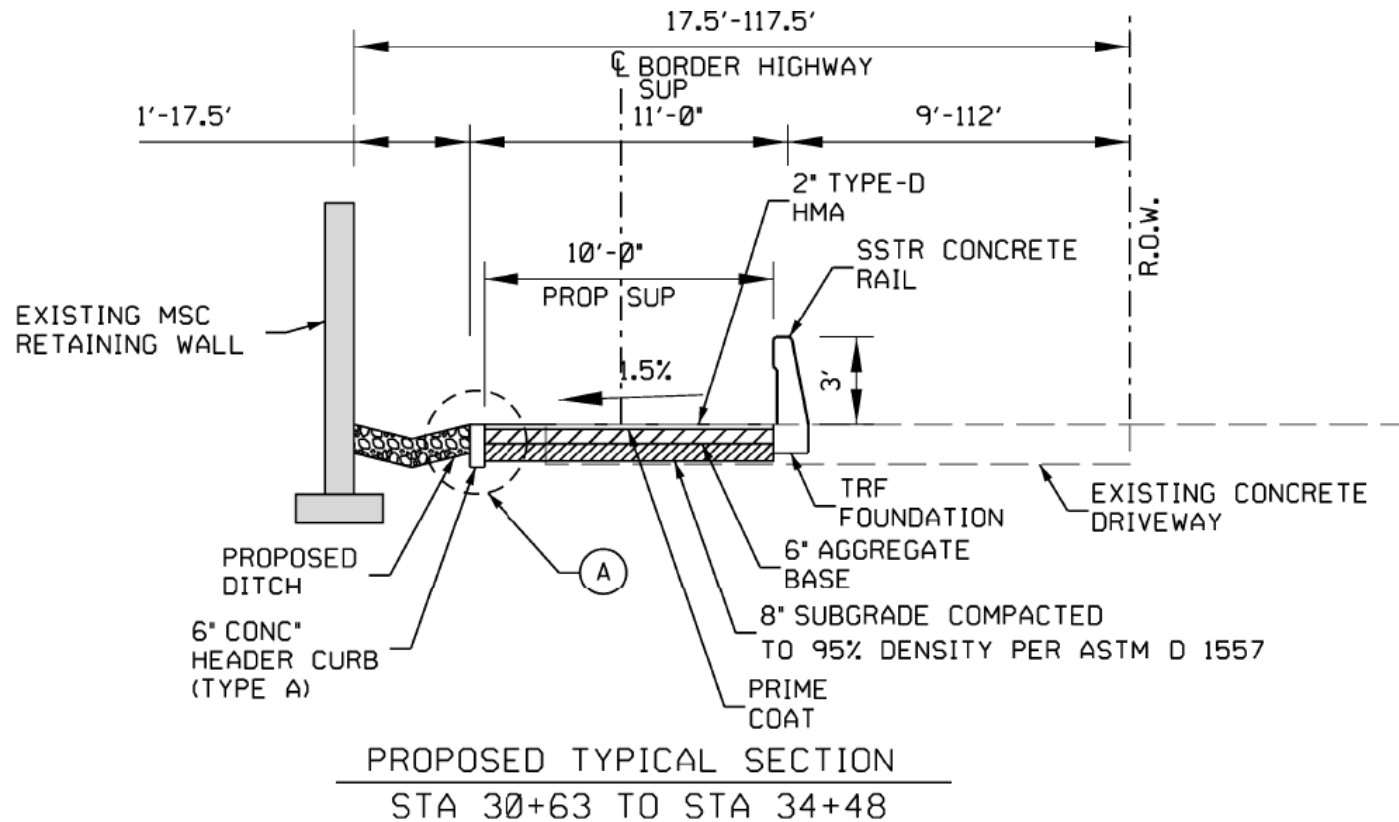

This text box is to remind you about the ASL translator service. Do NOT add any info in this space.

REMOVE THIS BOX ONCE THE PRESENTATION IS FINALIZED.

Proposed Cross Section

This text box is to remind you about the ASL translator service. Do NOT add any info in this space.

REMOVE THIS BOX ONCE THE PRESENTATION IS FINALIZED.

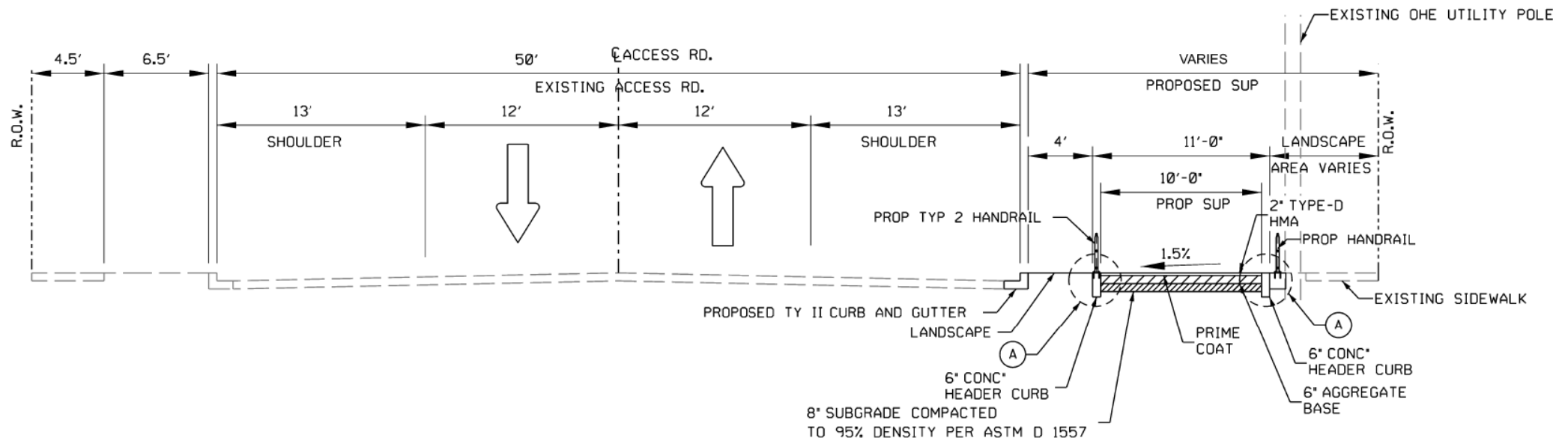

ACCESS ROAD PROPOSED TYPICAL SECTION
STA 34+88 TO END

Proposed Cross Section

This text box is to remind you about the ASL translator service. Do NOT add any info in this space.

REMOVE THIS BOX ONCE THE PRESENTATION IS FINALIZED.

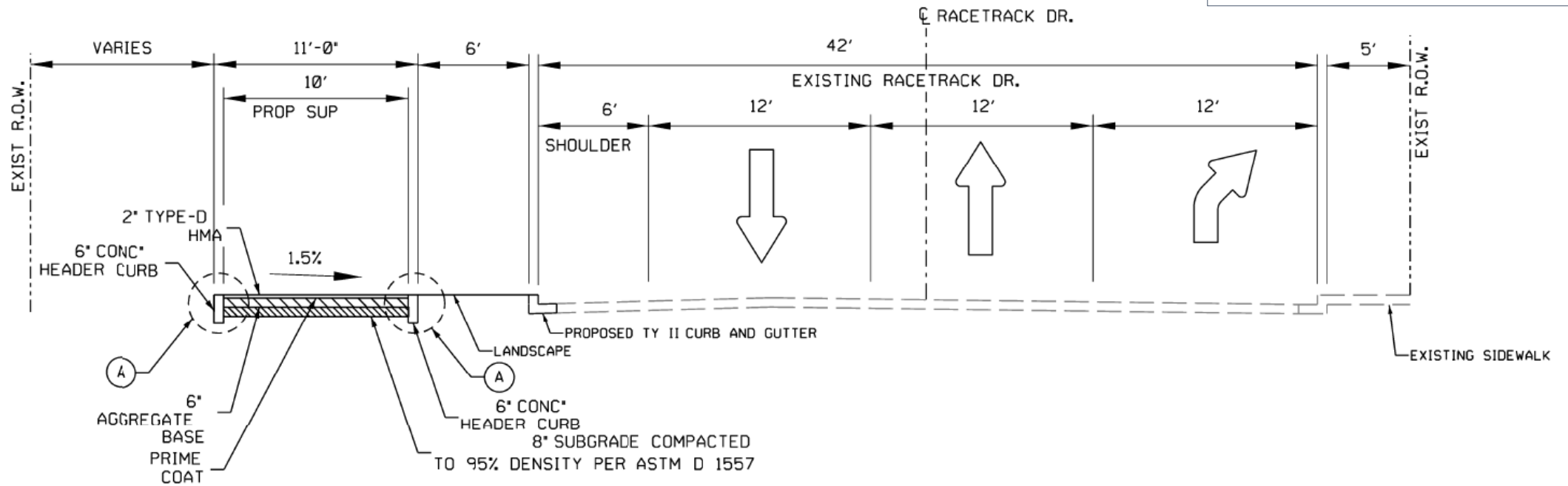

RACETRACK PROPOSED TYPICAL SECTION

STA 10+00 TO STA 11+83.15

Existing Conditions



This text box is to remind you about the ASL translator service. Do NOT add any info in this space.

REMOVE THIS BOX ONCE THE PRESENTATION IS FINALIZED.

Project Costs

- Estimated construction cost \$989,526.81
- Construction time: 8 Months
- Access to all properties will be maintained opened at all times



This text box is to remind you about the ASL translator service. Do NOT add any info in this space.

REMOVE THIS BOX ONCE THE PRESENTATION IS FINALIZED.

Procurement Summary

- **Low Bid**

- **Solicitation advertised on:**

- **April 23, 2023 and April 30, 2023**
- **6 firms submitted bids, 6 local vendors**

- **Recommendation**

- **To award the construction contract to Martinez Bros. Contractors, LLC. in the amount of \$989,526.81**
- **Construction Schedule**
- **Start: Summer / 2024**
- **End: Spring / 2025**

This text box is to remind you about the ASL translator service. Do NOT add any info in this space.

REMOVE THIS BOX ONCE THE PRESENTATION IS FINALIZED.

Thankyou