

Oscar Leeser  
Mayor

Tommy Gonzalez  
City Manager



CITY COUNCIL  
Peter Svarzbein, District 1  
Alexandra Anello, District 2  
Cassandra Hernandez, District 3  
Joe Molinar, District 4  
Isabel Salcido, District 5  
Claudia L. Rodriguez, District 6  
Henry Rivera, District 7  
Cissy Lizarraga, District 8

## **AGENDA FOR THE REGULAR COUNCIL MEETING**

---

**August 02, 2022**

**COUNCIL CHAMBERS, CITY HALL, 300 N. CAMPBELL AND VIRTUALLY  
9:00 AM**

**THE LOCAL HEALTH AUTHORITY STRONGLY RECOMMENDS THE USE OF  
MASKS IN ALL CITY FACILITIES AND INDOOR SPACES**

**Teleconference phone number: 1-915-213-4096**

**Toll free number: 1-833-664-9267**

**Conference ID: 487-453-246#**

**AND**

**AGENDA REVIEW MEETING  
COUNCIL CHAMBERS, CITY HALL  
300 N. CAMPBELL AND VIRTUALLY**

**August 1, 2022**

**9:00 AM**

**Teleconference phone number: 1-915-213-4096**

**Toll free number: 1-833-664-9267**

**Conference ID: 667-015-091#**

Notice is hereby given that an Agenda Review Meeting will be conducted on August 1, 2022 at 9:00 A.M. and a Regular Meeting of the City Council of the City of El Paso will be conducted on August 2, 2022 at 9:00 A.M. Members of the public may view the meeting via the following means:

Via the City's website. <http://www.elpasotexas.gov/videos>

Via television on City15,

YouTube: <https://www.youtube.com/user/cityofelpasotx/videos>

In compliance with the requirement that the City provide two-way communication for members of the public, members of the public may communicate with Council during public comment, and regarding agenda items by calling the following number:

1-915-213-4096 or Toll free number: 1-833-664-9267

**At the prompt please enter the corresponding Conference ID:**

**Agenda Review, August 1, 2022 Conference ID: 667-015-091#  
Regular Council Meeting, August 2, 2022 Conference ID: 487-453-246#**

**The public is strongly encouraged to sign up to speak on items on this agenda before the start of this meeting on the following links:**

**<https://www.elpasotexas.gov/city-clerk/meetings/city-council-meetings>**

**For Call to the Public: <https://elpasotx.seamlessdocs.com/f/SpeakerSignUpFormPublic>**

**To speak on Agenda Items: <https://elpasotx.seamlessdocs.com/f/SpeakerSignUpFormItem>**

**A quorum of City Council must participate in the meeting.**

### **ROLL CALL**

### **INVOCATION BY EL PASO POLICE CHAPLAIN JOE MARATTA**

#### **PLEDGE OF ALLEGIANCE**

#### **MAYOR'S PROCLAMATIONS**

**El Paso Strong Day**

**Blood Donors Appreciation Day**

**Professional Engineers Day**

#### **MAYOR'S RECOGNITION:**

**Wally Cech**

#### **NOTICE TO THE PUBLIC**

All matters listed under the CONSENT AGENDA, including those on the Addition to the Agenda, will be considered by City Council to be routine and will be enacted by one motion unless separate discussion is requested by Council Members. Prior to the vote, members of the audience may ask questions regarding items on the consent agenda. When the vote has been taken, if an item has not been called out for separate discussion, the item has been approved. Council may, however, reconsider any item at any time during the meeting.

#### **CONSENT AGENDA - APPROVAL OF MINUTES:**

## **Goal 6: Set the Standard for Sound Governance and Fiscal Management**

1. Approval of the Minutes of the Regular City Council Meeting of July 19, 2022, the Agenda Review of July 18, 2022, and the Work Session of July 18, 2022. [22-966](#)

### **All Districts**

City Clerk's Office, Laura D. Prine, (915) 212-0049

## **CONSENT AGENDA - REQUEST TO EXCUSE ABSENT CITY COUNCIL MEMBERS:**

2. REQUEST TO EXCUSE ABSENT CITY COUNCIL MEMBERS [22-967](#)

## **CONSENT AGENDA - RESOLUTIONS:**

### **Goal 1: Create an Environment Conducive to Strong, Sustainable Economic Development:**

3. That the City Manager be authorized to sign an Underground Electrical and Transformer Pad Easement for six (6) Easements, hereinafter referred to as ("Easement"), to accommodate an electrical transmission line to provide electrical power to property in the vicinity of the El Paso International Airport, said easement more particularly described as: A portion of Lot 1, Block 11, Butterfield Trail Industrial Park Unit Two, City of El Paso, El Paso County, Texas. [22-952](#)

### **District 3**

Airport, Sam Rodriguez, (915) 212-7301

### **Goal 7: Enhance and Sustain El Paso's Infrastructure Network**

4. That the City Manager be authorized to sign a Second Amendment to an On-Call agreement for Professional Services with EMC Engineers, Inc., a Texas corporation, to provide for additional services at a cost not to exceed Forty-Eight Thousand Five Hundred Fifty-Five Dollars (\$48,555.00), thereby increasing the contract amount from Three Hundred Fifty Thousand Dollars (\$350,000.00) to Three Hundred Ninety- Eight Thousand Five Hundred Fifty-Five Dollars (\$398,555.00); and that the City Manager be authorized to establish the funding sources and make any necessary budget transfers and execute any and all documents necessary for the execution of the Second Amendment. [22-962](#)

### **District 3**

Capital Improvement Department, Yvette Hernandez, (915) 212-1860

5. That the City Manager, or designee, be authorized to sign an Advance Funding Agreement by and between the City of El Paso and the State of Texas, acting by and through the Texas Department of Transportation, for Paso del Norte (PDN) Trail Magoffin Shared Use Path project, which has an estimated total [22-965](#)

project cost of \$1,308,751.00 of which the estimated local government participation amount is estimated at \$253,264.00. Further, that the City Manager, or designee, is authorized to sign all documents, agreement amendments, and perform all actions required to carry out the obligations of the City under this agreement.

**District 8**

Capital Improvement Department, Yvette Hernandez, (915) 212-1860

- 6. The linkage to the Strategic Plan is subsection 7.2 - Improve competitiveness through infrastructure improvements impacting the quality of life. [22-971](#)

Request that the Purchasing Director be authorized to notify M.J. Mader Enterprises, Inc. dba Bio Dyne Chemical Co. that the City is terminating Contract No. 2022-0156 Motor Oil, Antifreeze, Lubricants, Transmission and Hydraulic Oils & Fluids for convenience, pursuant to the provisions and requirements of Part 4, Section 8, Paragraph A of the Contract Clauses, and that the termination shall be effective as of August 2, 2022.

**All Districts**

Purchasing and Strategic Sourcing, Claudia A. Garcia, (915) 212-1218  
Streets and Maintenance, Richard J. Bristol, (915) 212-7000

**Goal 8: Nurture and Promote a Healthy, Sustainable Community**

- 7. A Resolution that the City Council designates the Director of the Department of Animal Services to be the Local Rabies Control Authority to enforce the provisions of the Texas Health and Safety Code, Section 826.017. [22-961](#)

**All Districts**

Animal Services Department, Terry Kebschull, (915) 212-8742

- 8. A Resolution that the City Manager or designee be authorized to sign a Local Government Approval Letter for nonprofit organizations conducting Emergency Solutions Grant (ESG) Shelter Activities, approving the emergency shelter activities provided by El Paso Human Services, Inc. within the City of El Paso. [22-964](#)

**All Districts**

Community and Human Development, Nicole Ferrini, (915) 212-1659

**CONSENT AGENDA - BOARD RE-APPOINTMENTS:**

**Goal 7: Enhance and Sustain El Paso's Infrastructure Network**

- 9. Eugenia Posada to the Bicycle Advisory Committee by Representative Joe Molinar, District 4. [22-973](#)

Members of the City Council, Representative Joe Molinar, (915) 212-0004

**CONSENT AGENDA - BOARD APPOINTMENTS:**



**Goal 4: Enhance El Paso’s Quality of Life through Recreational, Cultural and Educational Environments**

- 10. Rene Hurtado to the Greater El Paso Civic, Convention and Tourism Advisory Board by Representative Aleksandra Anello, District 2. [22-993](#)  
Members of the City Council, Representative Aleksandra Anello, (915) 212-0002.
- 11. Holly Packard Cobb to the Greater El Paso Civic, Convention, and Tourism by Representative Cissy Lizarraga, District 8. [22-1004](#)  
Members of the City Council, Representative Cissy Lizarraga, (915) 212-0008.

**Goal 6: Set the Standard for Sound Governance and Fiscal Management**

- 12. Valerie M. Armendariz to the Tax Advisory Committee by Representative Joe Molinar, District 4. [22-974](#)  
Members of the City Council, Representative Joe Molinar, (915) 212-0004.

**Goal 8: Nurture and Promote a Healthy, Sustainable Community**

- 13. Elisa Morales to the Women’s Rights Commission by Representative Cassandra Hernandez, District 3. [22-994](#)  
Members of the City Council, Representative Cassandra Hernandez, (915) 212-0003.
- 14. Nydia Correa to the Women’s Right Commission by Representative Cissy Lizarraga, District 8. [22-1005](#)  
Members of the City Council, Representative Cissy Lizarraga, (915) 212-0008.

**CONSENT AGENDA - APPLICATIONS FOR TAX REFUNDS:**

**Goal 6: Set the Standard for Sound Governance and Fiscal Management**

- 15. That the tax refunds listed on the attachment posted with this agenda be approved. This action would allow us to comply with state law which requires approval by the legislative body of refunds of tax overpayments greater than \$2,500.00. (See Attachment A) [22-955](#)  
**All Districts**  
Tax Office, Maria O. Pasillas, (915) 212-1737
- 16. That the tax refunds listed on the attachment posted with this agenda be approved. This action would allow us to comply with state law which requires approval by the legislative body of refunds of tax overpayments exceeding the three (3) year limit. (See Attachment B) [22-956](#)

**All Districts**

Tax Office, Maria O. Pasillas, (915) 212-1737

**CONSENT AGENDA - NOTICE OF CAMPAIGN CONTRIBUTIONS:**

**Goal 5: Promote Transparent and Consistent Communication Amongst All Members of the Community**

- 17. For notation pursuant to Section 2.92.080 of the City Code, receipt of campaign contribution by Representative Cassandra Hernandez of \$500 from the El Paso Association of Contractors. [22-992](#)  
Members of the City Council, Representative Cassandra Hernandez, (915) 212-0003
  
- 18. For notation pursuant to Section 2.92.080 of the City Code, receipt of campaign contributions by Representative Joe Molinar in the amount of \$500 from the El Paso Chapter Associated General. [22-999](#)  
Members of the City Council, Representative Joe Molinar, (915) 212-0004
  
- 19. For notation pursuant to Section 2.92.080 of the City Code, receipt of campaign contributions by City Representative Aleksandra Anello: El Paso Association of Contractors \$500. [22-1001](#)  
Members of the City Council, Representative Aleksandra Anello, (915) 212-0002

**REGULAR AGENDA - MEMBERS OF THE CITY COUNCIL**

**Goal 4: Enhance El Paso’s Quality of Life through Recreational, Cultural and Educational Environments**

- 20. Discussion and action that the City Council declares that the expenditure of District 8 discretionary funds in an amount not to exceed \$2,500.00 for the Children’s Camp Program at the El Paso Museum of History serves a municipal purpose of enhancing the quality of life through recreational, cultural and educational environments for El Paso residents; and that the City Manager be authorized to effectuate any budget transfer necessary to ensure that the funds are properly expended for such purpose and to execute any related agreements and amendments to such agreements. [22-1002](#)  
  
**District 8**  
Members of the City Council, Representative Cissy Lizarraga, (915) 212-0008

**Goal 5: Promote Transparent and Consistent Communication Amongst All Members of the Community**

- 21. Update, discussion, action by City Clerk and City Manager on city staff progress in reviewing and certifying the “Climate Charter” petition submitted by Ground Game Texas. [22-997](#)

**All Districts**

Members of the City Council, Representative Aleksandra Anello, (915) 212-0002

- 22. Discussion and action on City readiness to consider an ordinance on August 16, 2022, to place the Climate Charter initiative on the November 8, 2022, general election ballot, in the event that the petition is certified by the City Clerk. [22-996](#)

**All Districts**

Members of the City Council, Representative Aleksandra Anello, (915) 212-0002

**REGULAR AGENDA - OPERATIONAL FOCUS UPDATES**

**Goal 7: Enhance and Sustain El Paso’s Infrastructure Network**

- 23. Update from the El Paso County’s Planning and Development Department and Camino Real Regional Mobility Authority regarding the Pellicano Widening Project (TxDOT CSJ 0924-06-534). [22-970](#)

**All Districts**

Capital Improvement Department, Yvette Hernandez, (915) 212-1860

**CALL TO THE PUBLIC – PUBLIC COMMENT:**

**Call to the Public will begin at 12:00 p.m. Requests to speak must be received by 9:00 a.m. on the date of the meeting. Sixty minutes in total will be devoted for Call to the Public. This time is reserved for members of the public who would like to address the City Council on items that are not on the City Council Agenda.**

**Members of the public may communicate with Council during public comment, and regarding agenda items by calling 1-915-213-4096 or toll free number 1-833-664-9267 at the prompt please enter the following Conference ID: 487-453-246#**

**A sign-up form is available on line for those who wish to sign up in advance of the meeting at: <https://elpasotx.seamlessdocs.com/f/SpeakerSignUpFormPublic>**

**REGULAR AGENDA - FIRST READING OF ORDINANCES:**

**INTRODUCTION OF ORDINANCES PURSUANT TO SECTION 3.9 OF THE EL PASO CITY CHARTER:**

**Public comment typically is not taken during the first reading of ordinances. Public comments are invited at the date of the scheduled public hearing.**

Public Hearings will be held as part of the regular City Council meeting that begins at approximately 9:00 a.m. All interested persons present shall have an opportunity to be heard at that time. After the public hearings, Council may also delay taking action on Ordinances; no requirement is made by Section 3.9B of the El Paso City Charter to publish any further notice. Copies of all Ordinances are available for review in the City Clerk’s office, 300 N. Campbell, Monday through Thursday, 7:00 a.m. to

6:00 p.m.

**Goal 6: Set the Standard for Sound Governance and Fiscal Management**

24. An Ordinance of the City Council of the City of El Paso, Texas, ordering a Special Election for the submission of Charter Amendments to Section 2.2C to allow persons to serve two full terms as Mayor or District Representative if such person carried out an unexpired term; Section 3.18 to allow City Council to authorize leases for 40 years or less by Resolution or Ordinance; Section 3.5A to allow Council to reschedule meetings for holidays and allow the Mayor to cancel a Council meeting if required due to Declared Emergency; Section 3.9B, 3.10B, and 6.1-12 to align to State law and update obsolete references; Section 3.11 to remove the requirement for a second petition in initiatives, and provide a procedure for citizens to initiate City Ordinances; Section 1.2, 3.5E, 3.6, 4.1B, 4.3 and 7.3 to authorize the Mayor to vote on all Council items, removing the tie-breaking and veto capacity; Section 6.1-4 to authorize the City to create a policy regarding membership on the Civil Service Commission to reflect the community and City Workforce; Sections 6.2-2 and 6.2-3 to align the employee serving as Civil Service Commission Recorder with other employees carrying out similar duties; Section 6.7-1 and 6.8-1 to allow the City to establish more flexible policies in hiring employees; Section 6.13-11D to establish the City contribution to the Police and Fire Pension Fund of no less than 18% of the wages of the participants, and remove the limit on the City's contribution; such Election to be held within the City, on November 8, 2022; making provisions for the conduct of the Election; and authorizing a contract with El Paso County to furnish election services and equipment; providing for severability and setting an effective date.

[22-995](#)

**All Districts**

Communications and Public Affairs, Laura Cruz-Acosta, (915) 212-1061

**PUBLIC HEARING WILL BE HELD ON AUGUST 16, 2022**

**REGULAR AGENDA – OTHER BIDS, CONTRACTS, PROCUREMENTS:**

**Goal 7: Enhance and Sustain El Paso's Infrastructure Network**

25. The linkage to the Strategic Plan is subsection 7.2 - Improve competitiveness through infrastructure improvements impacting the quality of life.

[22-963](#)

**Award Summary:**

Discussion and action on the award of Solicitation 2022-0271 Ysleta Middle School Rapid Transit System (RTS) to ALLEN CONCRETE, LLC for an estimated award of \$625,384.55. The project consists of installation of school zone flashers along Independence Drive, Americans with Disability Act (ADA) ramps at multiple locations, and school zone signs will be upgraded to meet the Manual on Uniform Traffic Control Devices (MUTCD) standards at Ysleta Middle School. Bicycle lanes will be installed at Davis Dr. / Elvin Way between Alameda Avenue and Victor Lane. There will also be a hike & bike trail along Playa Lateral between Elvin Way and Jesuit Drive.

Department: Capital Improvement  
Award to: ALLEN CONCRETE, LLC  
El Paso, TX  
Item(s): Base Bid I  
Initial Term: 117 Consecutive Calendar Days  
Base Bid: \$625,384.55  
Total Estimated Award: \$625,384.55  
Funding Source: Capital Projects and Federal Highway Administration  
Account: 190-4950-580270-38170- PCP21TRAN02  
District(s): 7

This is a Low Bid procurement, unit price contract.

The Purchasing and Strategic Sourcing and Capital Improvement Department recommend award as indicated to ALLEN CONCRETE, LLC, the lowest responsive and responsible bidder.

It is requested that the City Manager be authorized to establish the funding sources and make any necessary budget transfers and execute any and all documents necessary for execution of this award.

Work under this unit price contract is only an estimated value and will be ordered, performed, invoiced, and paid by measured quantity. The actual cost of this contract may be higher or lower than the total estimated value and will be the sum total of unit prices at the end of the contract term.

As a part of this award, upon the review of the City Attorney, the City Engineer may without further authorization from City Council approve contract changes which are necessary for proper execution of the work and carrying out the intent of the project, which are in accordance with applicable law, do not make changes to the prices and are within the appropriate budget.

**District 7**

Purchasing and Strategic Sourcing, Claudia A. Garcia, (915) 212-1218  
Capital Improvement Department, Yvette Hernandez, (915) 212-1860

**REGULAR AGENDA – INTRODUCTION AND PUBLIC HEARINGS:**

- 26. An Ordinance authorizing the issuance of City of El Paso, Texas, Water and Sewer Revenue Bonds, in one or more series, in an aggregate amount not to exceed \$441,000,000 for System improvements and to refund certain obligations issued for System improvements; and resolving matters which are necessary to effect such issuance, including the delegation of matters relating to the sale and issuance of the bonds to an authorized City officer or employee within certain specified parameters. [22-953](#)

**All Districts**

El Paso Water, Arturo Duran, (915) 594-5549

- 27. An Ordinance authorizing the issuance of “City of El Paso, Texas, Municipal [22-954](#)

Drainage Utility System Revenue Refunding Bonds, Series 2023” in an amount not to exceed \$25,330,000 to refund certain previously issued obligations of the City; and resolving matters which are necessary to effect such issuance, including the delegation of matters relating to the sale and issuance of the bonds to an authorized City officer or employee within certain specified parameters.

**All Districts**

El Paso Water, Arturo Duran, (915) 594-5549

**REGULAR AGENDA – PUBLIC HEARINGS AND SECOND READING OF ORDINANCES:**

**Goal 3: Promote the Visual Image of El Paso**

28. An Ordinance changing the zoning of a portion of Tract 9A1, 9B1, Laura E. Mundy Survey 238 and a portion of Nellie D. Mundy Survey No. 244, City of El Paso, El Paso County, Texas from R-5/c (Residential/conditions) to C-2/c (Commercial/conditions) and from R-5/sp (Residential/special permit) to C-2 (Commercial) and imposing conditions. The penalty is as provided for in Chapter 20.24 of the El Paso City Code. [22-754](#)

The proposed rezoning meets the intent of the Future Land Use designation for the property and is in accordance with Plan El Paso, the City’s Comprehensive Plan.

Subject Property: Generally North of Transmountain Road and East of Interstate 10

Applicant: EP Transmountain Residential, LLC. PZRZ22-00009  
[POSTPONED FROM 07-19-2022]

**District 1**

Planning and Inspections, Philip F. Etiwe, (915) 212-1553  
Planning and Inspections, Andrew Salloum, (915) 212-1603

29. An Ordinance changing the zoning of a portion of the East 300 feet of North 150 feet of South 165 feet of Tract 9-D, First Supplemental Map of Parkland Addition, City of El Paso, El Paso County, Texas from R-4 (Residential) to A-O (Apartment/Office) and imposing conditions. The penalty is as provided for in Chapter 20.24 of the El Paso City Code. [22-848](#)

The proposed rezoning meets the intent of the Future Land Use designation for the property and is in accordance with Plan El Paso, the City’s Comprehensive Plan.

Subject Property: North of Woodrow Bean Transmountain Drive and East of Bomarc Street

Applicant: CEA Group, PZRZ22-00015

**District 4**

Planning and Inspections, Philip F. Etiwe, (915) 212-1553  
Planning and Inspections, Nina Rodriguez, (915) 212-1561

30. An Ordinance granting a Special Privilege License to 1031 Firestone, LLC to permit the construction, installation, maintenance use and repair of an aerial encroachment of an outdoor stairway for additional access to the property located at 1025 Texas Avenue, El Paso, Texas; setting the License term for a term of fifteen years (15) with one (1) renewable fifteen (15) year term.

[22-920](#)

Subject Property: 1025 Texas  
Applicant: 1031 Firestone, LLC., NESV2022-00002

**District 8**

Planning and Inspections, Philip F. Etiwe, (915) 212-1553  
Planning and Inspections, Armida R. Martinez, (915) 212-1605

**Goal 7: Enhance and Sustain El Paso's Infrastructure Network**

31. An Ordinance amending Title 12 (Vehicles and Traffic), Chapter 12.88 (Schedules), Section 12.88.150 (Schedule XIV-Speed Limits), to amend paragraph N (Speed limits on the following of Pershing Drive and Dyer Street) subparagraph 2; and to amend by deleting paragraph N-(Speed limits on the following of Pershing Drive and Dyer Street) subparagraph 3, to amend by deleting paragraph N (Speed limits on the following of Pershing Drive and Dyer Street) subparagraph 4; and to amend by deleting paragraph N (Speed limits on the following of Pershing Drive and Dyer street) subparagraph 5; the penalty being provided in Chapter 12.84 of the El Paso City Code.

[22-861](#)

**Districts 2 and 4**

Streets and Maintenance, Randy Garcia, (915) 212-7005

**REGULAR AGENDA - OTHER BUSINESS:**

**Goal 1: Create an Environment Conducive to Strong, Sustainable Economic Development**

32. Discussion and action on the approval of a Resolution to authorize the Director of Aviation to sign and submit a grant application and related documentation to the Federal Aviation Administration (FAA) and be designated the official representative of the City of El Paso to act in connection with the application process for the Airport Improvement Program (AIP) Project No. 3-48-0077-047-2022. That upon approval and issuance of such grant by the FAA, the City Manager be authorized to accept and sign the grant agreement, any related grant modifications, and other necessary documents when the form and substance of those documents has been reviewed and approved by the City Attorney's Office, and that such authorization will include the ability to accept and sign multiple agreements and documents, as the FAA grant may be issued in various disbursements. That the City Manager be authorized to approve and sign any budget transfers needed to establish appropriations in connection with this grant. The total grant amount shall include a federal estimated share of \$13,070,029 and an estimated match of \$2,002,565 to be paid for with Airport Enterprise Funds, totaling \$15,072,594 for the following projects: RWY 8R-26L & Connecting Taxiways Rehabilitation, and RWY

[22-972](#)



8R-26L Reconstruction - Taxiway U from Customs Ramp to TWY V Reconstruction.

**All Districts**

Airport, Sam Rodriguez, (915) 212-7301

**EXECUTIVE SESSION**

The City Council of the City of El Paso may retire into EXECUTIVE SESSION pursuant to Section 3.5A of the El Paso City Charter and the Texas Government Code, Chapter 551, Subchapter D, to discuss any of the following: (The items listed below are matters of the sort routinely discussed in Executive Session, but the City Council of the City of El Paso may move to Executive Session any of the items on this agenda, consistent with the terms of the Open Meetings Act and the Rules of City Council.) The City Council will return to open session to take any final action and may also, at any time during the meeting, bring forward any of the following items for public discussion, as appropriate.

- Section 551.071      CONSULTATION WITH ATTORNEY
- Section 551.072      DELIBERATION REGARDING REAL PROPERTY
- Section 551.073      DELIBERATION REGARDING PROSPECTIVE GIFTS
- Section 551.074      PERSONNEL MATTERS
- Section 551.076      DELIBERATION REGARDING SECURITY DEVICES OR SECURITY AUDITS
- Section 551.087      DELIBERATION REGARDING ECONOMIC DEVELOPMENT NEGOTIATIONS
- Section 551.089      DELIBERATION REGARDING SECURITY DEVICES OR SECURITY AUDITS; CLOSED MEETING

**Goal 6: Set the Standard for Sound Governance and Fiscal Management**

**Discussion and action on the following:**

- EX1.** Consultation with attorney regarding a petition for charter amendments. Matter No. 22-1065-153 (551.071) [22-978](#)  
City Attorney's Office, Kristen Hamilton-Karam, (915) 212-0033
  
- EX2.** Rubio, Arturo vs. City of El Paso; Cause No. 2021DCV2074. Matter No. 21-1036-3478 (551.071) [22-977](#)  
City Attorney's Office, Mathew Engelbaum, (915) 212-0033
  
- EX3.** Application of El Paso Electric Company to Change Rates to Open Access Transmission Tariff, Federal Energy Regulatory Commission (FERC); Docket No. ER22-282-000. Matter No. 21-1008-183 (551.071) [22-979](#)  
City Attorney's Office, Donald Davie, (915) 212-0033
  
- EX4.** Application for Approval of Advanced Metering System (AMS) Deployment Plan, AMS Surcharge, and Non-Standard Metering Service Fees, Public Utility Commission of Texas Docket No. 52040. Matter No 21-1008-168 (551.071) [22-980](#)  
City Attorney's Office, Donald Davie, (915) 212-0033



**EX5.** Purchase, lease, exchange of real property located in El Paso, Texas. Matter No. 22-1004-1402 (551.072)

[22-983](#)

Economic and International Development, Karina Brasgalla, (915) 212-1570

## **ADJOURN**

### **NOTICE TO THE PUBLIC:**

Sign Language interpreters are provided for regular City Council meetings. If you need Spanish Interpreter Services, you must email [CityClerk@elpasotexas.gov](mailto:CityClerk@elpasotexas.gov) at least 72 hours in advance of the meeting.

**ALL REGULAR CITY COUNCIL AGENDAS ARE PLACED ON THE INTERNET ON THURSDAY PRIOR TO THE MEETING AT THE ADDRESS BELOW:**

<http://www.elpasotexas.gov/>



El Paso, TX

300 N. Campbell  
El Paso, TX

Legislation Text

---

**File #: 22-966, Version: 1**

---

**CITY OF EL PASO, TEXAS  
LEGISTAR AGENDA ITEM SUMMARY FORM**

**DISTRICT, DEPARTMENT, CONTACT INFORMATION:**

*Please choose District and Department from drop down menu. Please post exactly as example below.  
No Title's, No emails. Please use ARIAL 10 Font.*

**All Districts**

City Clerk's Office, Laura D. Prine, (915) 212-0049

**AGENDA LANGUAGE:**

*This is the language that will be posted to the agenda. Please use ARIAL 11 Font.*

Approval of the Minutes of the Regular City Council Meeting of July 19, 2022, the Agenda Review of July 18, 2022, and the Work Session of July 18, 2022.

OSCAR LEESER  
MAYOR



CITY COUNCIL  
PETER SVARZBEIN, DISTRICT 1  
ALEXSANDRA ANNELLO, DISTRICT 2  
CASSANDRA HERNANDEZ, DISTRICT 3  
JOE MOLINAR, DISTRICT 4  
ISABEL SALCIDO, DISTRICT 5  
CLAUDIA L. RODRIGUEZ, DISTRICT 6  
HENRY RIVERA, DISTRICT 7  
CISSY LIZARRAGA, DISTRICT 8

TOMMY GONZALEZ  
CITY MANAGER

**AGENDA REVIEW MINUTES  
COUNCIL CHAMBERS AND VIRTUALLY  
CITY HALL, 300 N. CAMPBELL  
July 18, 2022  
9:00 A.M.**

.....  
The City Council met at the above place and date. Meeting was called to order at 9:01 a.m. Mayor Leeser present and presiding. The following Council Members answered roll call: Peter Svarzbein, Alexsandra Annello, Joe Molinar, Claudia Rodriguez, and Henry Rivera. Late arrivals: Isabel Salcido at 9:04 a.m. and Cassandra Hernandez joined virtually at 9:03 a.m. Cissy Lizarraga requested to be excused.

The agenda items for the July 19, 2022 Regular City Council and Special Mass Transit Board Meetings were reviewed.

.....  
**17. REGULAR AGENDA – OPERATIONAL FOCUS UPDATES**

Provide an annual report to the City Council on the Stormwater Utility.

Ms. Karina Brascalla, Economic and International Development Assistant Director for Partnerships, commented.

Ms. Lisa Turner, citizen, commented.

.....  
**22. REGULAR AGENDA – OTHER BIDS, CONTRACTS, PROCUREMENTS**

Discussion and action on the award of Solicitation 2022-0672 Runway 8R-26L Rehabilitation to Jordan Foster Construction, LLC for an estimated award of \$13,092,848.45. The project consists of rehabilitating the pavement for Runway 8R-26L, associated taxiway connectors (TWY S, T, U, and V), and reconstructing a portion of Taxiway U.

Department: El Paso International Airport  
Award to: Jordan Foster Construction, LLC  
El Paso, TX  
Item(s): Base Bid I and Base Bid II  
Initial Term: 302 Consecutive Calendar Days  
Base Bid: \$8,847,160.95  
Base Bid II: \$4,245,687.50  
Total Estimated Award: \$13,092,848.45  
Funding Source: Federal Aviation Administration and Airport Enterprise  
Account: 562-3010-62330-580270- G62A204002  
562-3080-62335-580270- G62A204002

District(s): All

This is a Low Bid procurement, unit price contract.

The Purchasing & Strategic Sourcing and Aviation Departments recommend award as indicated to Jordan Foster Construction, LLC, the lowest responsive and responsible bidder.

It is requested that the City Manager be authorized to establish the funding sources and make any necessary budget transfers and execute any and all documents necessary for execution of this award.

Work under this unit price contract is only an estimated value and will be ordered, performed, invoiced, and paid by measured quantity. The actual cost or lower than the total estimated value and will be the sum total of unit prices at the end of the contract term.

As a part of this award, upon the review of the City Attorney, the City Engineer may without further authorization from City Council approve contract changes which are necessary for proper execution of the work and carrying out the intent of the project, which are in accordance with applicable law, do not make changes to the prices and are within the appropriate budget.

The following City staff members commented:

1. Mr. Derek Russell, Senior Purchasing Analyst
2. Mr. Sam Rodriguez, Chief Operations and Transportation Officer

Ms. Lisa Turner, citizen, commented.

.....  
**23. REGULAR AGENDA – OTHER BIDS, CONTRACTS, PROCUREMENTS**

Discussion and action on the award of Solicitation 2022-0402 Canterbury Trail Improvements to BLACK STALLION CONTRACTORS, INC. for an estimated total amount of \$2,967,572.40. This contract will allow for the construction of a trail that pedestrians, hikers, and bicyclists can use located along Canterbury Drive from Ridgecrest Drive to Stanton Street.

Department:	Capital Improvement
Award to:	BLACK STALLION CONTRACTORS, INC. El Paso, TX
Item(s):	Base Bid I, Base Bid II, Base Bid III, Base Bid IV, and Base Bid V
Initial Term:	300 Consecutive Calendar Days
Base Bid I:	\$956,239.81
Base Bid II:	\$503,908.92
Base Bid III:	\$97,967.47
Base Bid IV:	\$918,798.67
Base Bid V:	\$490,657.53
Total Estimated Award:	\$2,967,572.40
Funding Source:	2013 Street Infrastructure
Accounts:	190-4740-580270-28900-PCP20ST010
District(s):	1

This is a Competitive Sealed Proposal, unit price contract.

The Purchasing & Strategic Sourcing and Capital Improvement Departments recommend award as indicated to BLACK STALLION CONTRACTORS, INC. the highest ranked offeror, and the Horizonte Construction I, Ltd. be deemed nonresponsive due to submitting an incomplete price form. It is requested that the City Manager be authorized to establish the funding sources and

make any necessary budget transfers and execute any and all documents necessary for execution of this award.

Work under this unit price contract is only an estimated value and will be ordered, performed, invoiced, and paid by measured quantity. The actual cost of this contract may be higher or lower than the total estimated value and will be the sum total of unit prices at the end of the contract term.

As a part of this award, upon the review of the City Attorney, the City Engineer may without further authorization from City Council approve contract changes which are necessary for proper execution of the work and carrying out the intent of the project, which are in accordance with applicable law, do not make changes to the prices and are within the appropriate budget.

Representative Svarzbein commented.

Ms. Crystal Paz, Senior Procurement Analyst, commented.

.....  
**29. REGULAR AGENDA – PUBLIC HEARINGS AND SECOND READING OF ORDINANCES**

An Ordinance adopting the “El Paso Complete Streets Policy - July 2022” as an addendum to the City of El Paso’s Comprehensive Plan, “Plan El Paso”.

Representative Hernandez commented.

Mr. Joaquin Rodriguez, Capital Improvement Project Manager, commented.

.....  
Motion made by Representative Rivera, seconded by Representative Rodriguez, and unanimously carried to **ADJOURN** this meeting at 9:20 a.m.

AYES: Representatives Svarzbein, Annello, Hernandez, Molinar, Salcido, Rodriguez, and Rivera

NAYS: None

ABSENT: Representative Lizarraga

.....  
APPROVED AS TO CONTENT:

\_\_\_\_\_  
Laura D. Prine, City Clerk

OSCAR LEESER  
MAYOR

TOMMY GONZALEZ  
CITY MANAGER



CITY COUNCIL  
PETER SVARZBEIN, DISTRICT 1  
ALEXSANDRA ANNELLO, DISTRICT 2  
CASSANDRA HERNANDEZ, DISTRICT 3  
JOE MOLINAR, DISTRICT 4  
ISABEL SALCIDO, DISTRICT 5  
CLAUDIA L. RODRIGUEZ, DISTRICT 6  
HENRY RIVERA, DISTRICT 7  
CISSY LIZARRAGA, DISTRICT 8

**CITY COUNCIL WORK SESSION MINUTES**  
**July 18, 2022**  
**COUNCIL CHAMBERS, CITY HALL AND VIRTUALLY**  
**9:05 A.M.**

.....  
The City Council of the City of El Paso met at the above place and date. Meeting was called to order at 9:20 a.m. Mayor Oscar Leeser was present and presiding and the following Council Members answered roll call: Peter Svarzbein, Alexsandra Annello, Joe Molinar, Isabel Salcido, Claudia Rodriguez and Henry Rivera. Cassandra Hernandez joined virtually. Cissy Lizarraga requested to be excused.  
.....

**AGENDA**

.....  
1. Presentation and discussion by the COVID-19 Response and Recovery Cross-Functional Team providing information on key activities, efforts, and processes.

1. Overview (Tommy Gonzalez)

Mr. Tommy Gonzalez, City Manager, began the presentation by highlighting the increase in number of hospitalizations at this time and recommended the wearing of masks, hand sanitizing, and social distancing. Mr. Gonzalez provided the hours of operation and location on the four vaccination clinics throughout the City. He also provided vaccination rates, which remain higher than the state average and mentioned that the coordination with the school districts will soon resume to provide vaccinations during the back to school season.

2. City Attorney Overview (Karla Nieman)

- a. State Disaster Declaration
- b. Emergency Ordinances
- c. Greg Abbott, in his official capacity as Governor of Texas v. City of El Paso and Statewide Mask Mandate Litigation
- d. Additional Updates

Ms. Josette Flores, Senior Assistant City Attorney, continued with the presentation and stated that although the State Disaster Declaration has not yet been extended, it is expected that Governor Abbot will be doing so within the next two days adding that the local Emergency Ordinances will expire on July 22, 2022 and will need to be reenacted. Ms. Flores explained that there were no updates related to the mask mandate litigation and finalized her presentation by providing data on the COVID-19 related citations filed in the Municipal Courts, which include a total of 405 trial settings.

Representative Annello questioned the following City staff members:

- Mr. Sam Rodriguez, Chief Operations and Transportation Officer
- Mr. Joaquin Rodriguez, Capital Improvement Project Manager
- Ms. Tracey Jerome, Senior Deputy City Manager

3. Team Lead Report:

- a. Health Focus (Hector Ocaranza, M.D.)
- b. Community Vulnerabilities (Nicole Ferrini)
  - i. Utility Assistance

Dr. Hector Ocaranza, Public Health Authority, reiterated the information previously provided by Mr. Gonzalez regarding the high status of community infection due to the increased number in hospitalizations; he also made the recommendations on mask wearing, vaccination and boosting while reminding the public that COVID-19 is not over. He advised the community to continue testing and to be prepared for the fall and winter seasons with the expected increase in infections. Dr. Ocaranza proceeded to go over data related to the different variants and subvariants with BA.4 and BA.5 most prevalent in replacing the Omicron variant across the state. He added that young adults between the ages of 20-40 are the group with the higher number of infections while seniors make up the majority of hospitalizations.

Representative Svarzbein commented.

Ms. Nicole Ferrini, Community and Human Development Director Ferrini continued the presentation and briefed Council members on the support provided in conjunction with the Paso del Norte Community Foundation and Amistad to over 9,000 local families during the last two years amounting to a total of \$10M in rent and utility assistance for up to 12 months. She mentioned that rental assistance is no longer available but funds are still available for utility assistance. Ms. Ferrini concluded her presentation by urging people to contact Amistad to apply for utility assistance before funds expire.

4. City Manager Wrap-up (Tommy Gonzalez)

Mr. Gonzalez concluded the presentation with a reminder that the number of infections keep going up and mentioning that although the vaccination rate for youths ages 5 – 16, is currently at 51%, which compares to the state numbers, and said we need to remain focused on getting more people from this age group vaccinated especially with back to school around the corner.

**NO ACTION** was taken on this item.

2.

ITEMS 2 THROUGH 4 WERE TAKEN TOGETHER

ORDINANCE NO. 019349

**AN EMERGENCY ORDINANCE RE-ENACTING EMERGENCY ORDINANCE NO. 019035  
EXTENDING A DISASTER DECLARATION DUE TO A PUBLIC HEALTH EMERGENCY**

**WHEREAS**, on March 13, 2020, the Governor of the State of Texas declared a state of disaster and the President of the United States of America declared a national emergency in relation to COVID-19; and

**WHEREAS**, on March 13, 2020, the Mayor signed a Local Emergency Declaration and requested the aid of the State Government pursuant to Texas Government Code Section 418.108; and

**WHEREAS**, pursuant to El Paso City Code Section 2.48.020(C), a local state of disaster declaration may not be continued or renewed for a period in excess of seven days except by or with the consent of City Council; and

**WHEREAS**, City Charter Section 3.10 allows for the City Council to adopt an emergency ordinance to meet a public emergency affecting life, health, property or the public peace; and

**WHEREAS**, on March 17, 2020, the City Council adopted Emergency Ordinance No. 019035, Extending a Disaster Declaration Due to a Public Health Emergency; and

**WHEREAS**, since March 2020, El Paso City Council has re-enacted Emergency Ordinance No. 019035 monthly, with the most recent re-enactment taking place on June 21, 2022; and

**WHEREAS**, as of July 8, 2022, the number of COVID-19 active cases in El Paso is over 3,516; and

**WHEREAS**, pursuant to City Charter Section 3.10, every emergency ordinance shall stand repealed automatically as of the 31<sup>st</sup> day following the date on which it was adopted, but may be re-enacted to continue a Disaster Declaration; and

**WHEREAS**, Emergency Ordinance No. 019336 which re-enacts Emergency Ordinance No. 019035 is set to expire on July 21, 2022;

**WHEREAS**, the condition necessitating a declaration of a state of disaster continues to exist.

**NOW THEREFORE, BE IT ORDAINED BY THE CITY COUNCIL OF EL PASO, TEXAS:**

1. That the state of disaster proclaimed for the City of El Paso by the Mayor on March 13, 2020, and extended by Emergency Ordinance No. 019035, is hereby re-enacted and shall continue for thirty (30) days unless re-enacted in accordance with City Charter Section 3.10 or until terminated by City Council, whichever is sooner.
2. This ordinance is adopted as an emergency measure with the unanimous vote of the City Council Representatives present and the consent of the Mayor and pursuant to City Charter Section 3.10.

3.

**ORDINANCE NO. 019350**

**AN EMERGENCY ORDINANCE RE-ENACTING EMERGENCY ORDINANCE NO. 019036  
INSTITUTING EMERGENCY MEASURES, AS RE-ENACTED, RESTATED AND AMENDED**



**BY EMERGENCY ORDINANCE NO. 019151; AND FURTHER RE-ENACTED AND AMENDED BY EMERGENCY ORDINANCE NOS. 019156, 019169, 019191 and 019284; PENALTY AS PROVIDED IN SECTION 8**

**WHEREAS**, on March 13, 2020, the Governor of the State of Texas declared a state of disaster and the President of the United States of America declared a national emergency in relation to COVID-19; and

**WHEREAS**, by proclamation issued on March 13, 2020, the Mayor declared a local state of disaster for the City of El Paso resulting from a public health emergency; and

**WHEREAS**, on March 17, 2020, the City Council, pursuant to City Charter Section 3.10, adopted Emergency Ordinance No. 019036 to meet a public emergency affecting life, health, property or the public peace; and

**WHEREAS**, since March 2020, City Council has re-enacted Emergency Ordinance No. 019036 monthly, with the most recent re-enactment, re-statement and amendment taking place on March 16, 2021, and with the most recent re-enactment taking place on June 21, 2022; and

**WHEREAS**, pursuant to City Charter Section 3.10, every emergency ordinance shall stand repealed automatically as of the 31<sup>st</sup> day following the date on which it was adopted, but may be re-enacted if the emergency still exists; and

**WHEREAS**, a disaster continues to exist and requires that certain emergency measures be taken to meet a public emergency affecting life, health, property or the public peace; and

**WHEREAS**, the City Council desires to re-enact Emergency Ordinance No. 019036, as re-enacted, restated and amended on March 16, 2021 through Emergency Ordinance No. 019151, as further re-enacted and amended on March 29, 2021 through Emergency Ordinance No. 019156, as further re-enacted and amended on April 26, 2021 through Emergency Ordinance No. 019169, as further re-enacted and amended on May 24, 2021 through Emergency Ordinance No. 019191, as further re-enacted and amended on January 31, 2022 through Emergency Ordinance No. 019284, which shall remain in effect for thirty days or until otherwise terminated, re-enacted, or superseded by a conflicting El Paso Local Health Authority order, or state or federal law or order.

**NOW THEREFORE, BE IT ORDAINED BY THE CITY COUNCIL OF EL PASO, TEXAS:**

1. Emergency Ordinance No. 019036, as re-enacted, restated and amended by Emergency Ordinance No. 019151, and as further re-enacted and amended by Emergency Ordinance Nos. 019156, 019169, 019191, and 019284, penalty as provided in Section 8, is hereby re-enacted.
2. Emergency Ordinance No. 019036, as re-enacted, restated and amended by Emergency Ordinance No. 019151, and further re-enacted and amended by Emergency Ordinance Nos. 019156, 019169, 019191, and 019284, penalty as provided in Section 8, shall remain in full force and effect and continue for thirty (30) days unless re-enacted in accordance with City Charter Section 3.10 or until terminated by the City Council, whichever is sooner.

3. This ordinance is adopted as an emergency measure with the unanimous vote of the City Council Representatives present and the consent of the Mayor, pursuant to City Charter Section 3.10.

4.

**ORDINANCE 019351  
AN EMERGENCY ORDINANCE  
RE-ENACTING EMERGENCY ORDINANCE NO. 019241;  
ALLOWING TEMPORARY USES ON THE PUBLIC RIGHT OF WAY AND PRIVATE  
PROPERTY BY SUSPENDING VARIOUS CITY ORDINANCES; PENALTY AS  
PROVIDED IN SECTION 6.**

**WHEREAS**, on March 13, 2020, the Governor of the State of Texas declared a state of disaster and the President of the United States of America declared a national emergency in relation to COVID-19; and

**WHEREAS**, by proclamation issued on March 13, 2020, the Mayor declared a local state of disaster for the City of El Paso resulting from a public health emergency; and

**WHEREAS**, on March 17, 2020, El Paso City Council adopted Emergency Ordinance No. 019035 extending the City's Disaster Declaration due to a Public Health Emergency; and

**WHEREAS**, since March 2020, El Paso City Council has re-enacted Emergency Ordinance No. 019035, with the most recent re-enactment taking place on June 21, 2022; and

**WHEREAS**, Governor Abbott has similarly renewed the State's COVID- 19 Disaster Declaration, with the most recent extension taking place on June 21, 2022; and

**WHEREAS**, El Paso City Charter Section 3.10 allows City Council to adopt an emergency ordinance to meet a public emergency affecting life, health, property, or the public peace; and

**WHEREAS**, the El Paso City Council desires to support restaurants and similar establishments in their efforts to safely operate during the COVID-19 pandemic by further facilitating outdoor service and dining opportunities; and

**WHEREAS**, on October 11, 2021, City Council enacted an Emergency Ordinance Instituting Emergency Measures to Allow Temporary Uses on the Public Right of Way and Private Property by Suspending Various City Ordinances ("**Emergency Ordinance No. 019241**"); and

**WHEREAS**, pursuant to City Charter Section 3.10, every emergency ordinance shall stand repealed automatically as of the 31st day following the date on which it was adopted, but may be re-enacted if the emergency still exists; and

**WHEREAS**, City Council re-enacted Emergency Ordinance No. 019241, with the most recent re-enaction taking place on June 21, 2022 (Ord. No. 019338) ("**Re-enacting Ordinance**"); and

**WHEREAS**, a disaster continues to exist and requires that certain emergency measures be taken to meet a public emergency affecting life, health, property or the public peace; and

**WHEREAS**, City Council desires to re-enact its October 11, 2021, Emergency Ordinance No. 019241, which shall take effect immediately, and remain in effect until August 17, 2022 or until otherwise terminated, re-enacted, or superseded by a conflicting El Paso Local Health Authority order, or state or federal law or order.

**NOW THEREFORE, BE IT ORDAINED BY THE CITY COUNCIL OF EL PASO, TEXAS:**

1. That Emergency Ordinance No. 019241, is re-enacted and shall remain in full force and continue for thirty (30) days unless re-enacted in accordance with City Charter Section 3.10 or until terminated by the City Council, whichever is sooner;
2. This ordinance is adopted as an emergency measure with the unanimous vote of the City Council Representatives present and the consent of the Mayor and pursuant to City Charter Section 3.10.

Mr. Sam Rodriguez, Chief Operations and Transportation Officer, commented.

Ms. Lisa Turner, citizen, commented.

Motion made by Representative Rivera, second by Representative Molinar, and unanimously carried to **ADOPT** the Emergency Ordinances.

AYES: Representatives Svarzbein, Annelo, Hernandez, Molinar, Salcido, Rodriguez, and Rivera

NAYS: None

ABSENT: Representative Lizarraga

**Mayor Leeser consented to the adoption of the Emergency Ordinances.**

5.

**ORDINANCE NO. 019352**

**AN EMERGENCY ORDINANCE EXTENDING EMERGENCY  
ORDINANCE NO. 019333 AUTHORIZING THE CITY MANAGER TO ASSIGN  
PERSONNEL AND RESOURCES TO ASSIST IN ADDRESSING THE HUMANITARIAN  
AND PUBLIC SAFETY CRISIS RESULTING FROM A MASS MIGRATION THROUGH EL  
PASO**

**WHEREAS**, on May 23, 2022, the Mayor and City Council of the City of El Paso (the "City") passed an Emergency Ordinance No. 019333 "Authorizing the City Manager to Assign Personnel and Resources to Assist in Addressing the Humanitarian and Public Safety Crisis Resulting from a Mass Migration through the City of El Paso"; and

**WHEREAS**, thousands of migrants from Latin America have already gathered at or near the U.S.- Mexico border in hopes that President Biden will ease immigration restrictions that will make it easier to enter the United States; and

**WHEREAS**, because of war between Russia and Ukraine and the political situation in Turkey, Ukrainians, Russians, and Turks are arriving at the Southern border for admission to the United States; and

**WHEREAS**, on April 1, 2022, the Centers for Disease Control and Prevention (“CDC”) announced the repeal of the Public Health Services Act, 42 U.S.C. §265 (“Title 42”), which was expected to allow for the inflow of migrants from the southern border; and

**WHEREAS**, federal litigation ensued to enjoin the CDC from repealing Title 42 on the intended date of May 23, 2022; and

**WHEREAS**, on June 30, 2022, a United States Supreme Court ruling allowed the President to end the Migrant Protection Protocols, which would allow for the inflow of migrants from the southern border; and

**WHEREAS**, the Southwest had 239,416 land border encounters in the month of May, 2022; and

**WHEREAS**, the El Paso sector of CBP had 34,638 land border encounters in the month of May, 2022 and a total of 177,789 encounters for federal fiscal year 2022; and

**WHEREAS**, although Title 42 remains in place as a result of the federal litigation, the number of Border Patrol encounters remain high averaging 600 to 1000 per day; and

**WHEREAS**, due to this high volume, the number of refugees and asylum seekers amounts to 200-300 releases to the Annunciation House, a local non-governmental organization (“NGO”), on a daily basis; and

**WHEREAS**, on some days, the number of releases is lower due to the limited NGO space; and

**WHEREAS**, when the City faced a migrant surge in March of 2019, the NGO was able to establish over thirty hospitality sites throughout the El Paso region, versus today’s fifteen hospitality sites; and

**WHEREAS**, the primary challenge is that the NGO does not have the volunteer base to sustain or increase current capacity at its current hospitality sites (twelve in El Paso, Texas, three in Las Cruces, New Mexico, one in Deming, New Mexico, and another in Albuquerque, New Mexico); and

**WHEREAS**, although NGO volunteer recruitment efforts will continue, it is not anticipated that the volunteer base will keep up with the current demand, despite the NGO having identified additional facilities that could receive migrants; and

**WHEREAS**, when the U.S. Customs and Border Protection’s (“CBP”) Central Processing Center is over capacity and NGO space is unavailable, that is when the potential for street releases arises; and

**WHEREAS**, on May 15, 2022, the federal authorities released 119 single adults on the downtown streets of the City of El Paso; and

**WHEREAS**, in response to the May 15, 2022, street release, the El Paso City-County Office of Emergency Management (“OEM”) reallocated twenty-nine COVID-19 Operations staff

to assist as migrant shelter surge staff, and on May 17, 2022, this staff began orientation training at Casa del Refugiado, the NGO's largest hospitality site; and

**WHEREAS**, OEM has created a job specification, for general disaster operations to include humanitarian relief duties to hire and assign staff to assist with NGO capacity with 36 staff currently assigned; and

**WHEREAS**, the El Paso City Charter Section 3.10, allows for the adoption of one or more emergency ordinances to meet a public emergency affecting life, health, property, or the public peace; and

**WHEREAS**, Section 121.003 of the Texas Health & Safety Code states that a municipality may enforce any law that is reasonably necessary to protect public health; and

**WHEREAS**, Section 122.006 of the Texas Health & Safety Code provides home-rule municipalities express authority to adopt rules to protect the health of persons in the municipality, including quarantine rules to protect the residents against communicable disease; and

**WHEREAS**, OEM continues to provide COVID-19 isolation and quarantine hotel support to migrant shelters, expanding operations when outbreaks occur in congregate shelter facilities; and

**WHEREAS**, OEM has provided isolation and quarantine services to over 2,483 migrants in close coordination with NGOs since April 2020; and

**WHEREAS**, the release of mass groups of people without access to potable water, food, or shelter exposes the migrants and El Paso residents to the origination and spread of potential and actual disease; and

**WHEREAS**, there are significant public safety and security concerns related to the wave of migration, including but not limited to the risk to injury or loss of life with migrants in El Paso streets with little or no resources on days that reach hot or cold temperatures and the inherent risks that come with increased demand on local shelters; and

**WHEREAS**, for these reasons, the City is faced with the imminent threat of widespread injury or loss of life resulting from a surge in transient migrants traveling to the region during an ongoing global pandemic; and

**WHEREAS**, there is the potential for loss of property for both residents and migrants due to those who would take financial advantage of this wave of migrants; and

**WHEREAS**, the City of El Paso is home to 4 of the 28 international ports of entry between Texas and Mexico; and

**WHEREAS**, based on mass migration events in the recent past, the City anticipates significant delays at the international ports-of-entry to include trade; and

**WHEREAS**, the potential encampment of large groups of migrants on City rights of way and parks poses safety risks to migrants and citizens alike; and

**WHEREAS**, in awaiting the due support of the federal government, the City finds that the expenditure of public funds for staff to coordinate resources and supplies, serve as shelter surge staff and transport migrants released in the City of El Paso accomplishes a valid public purpose of protecting public infrastructure, and protecting the health, safety and welfare of the citizens of El Paso; and

**WHEREAS**, in order to protect the health of persons in the municipality, the City Council wishes to continue to assist the local NGO with surge staff, coordination of resources and supplies, and transportation in light of the continued high number of community releases; and

**WHEREAS**, OEM and the City will continue to prepare and evaluate the need for mass emergency sheltering in anticipation of the eventual repeal of Title 42 and other regional migration surges that may impact the El Paso region; and

**WHEREAS**, this Ordinance shall remain in effect until otherwise terminated, re-enacted, or superseded by a conflicting ordinance, El Paso Local Health Authority Ordinance, or state or federal law.

**NOW THEREFORE, BE IT ORDAINED BY THE CITY COUNCIL OF THE CITY OF EL PASO:**

1. That the Emergency Ordinance No. 019333 passed and adopted by the City Council of the City of El Paso on May 23, 2022 is hereby re-enacted and shall continue for thirty (30) days unless re-enacted in accordance with City Charter Section 3.10 or until terminated by City Council, whichever is sooner.
2. This ordinance is adopted as an emergency measure with the unanimous vote of the City Council Representatives present and the consent of the Mayor and pursuant to City Charter Section 3.10.

Assistant Fire Chief Jorge Rodriguez presented a PowerPoint presentation related to the mass migration situation in El Paso.

Mayor Leeser commented.

Motion made by Representative Anello, second by Representative Rivera, and unanimously carried to **ADOPT** the Emergency Ordinance.

AYES: Representatives Svarzbein, Anello, Hernandez, Molinar, Salcido, Rodriguez, and Rivera

NAYS: None

ABSENT: Representative Lizarraga

**Mayor Leeser consented to the adoption of the Emergency Ordinance.**

- 
6. Presentation of, and discussion and action on, the recommendation of the Ad Hoc Charter Advisory Committee.

Ms. Laura D. Prine, City Clerk, presented a PowerPoint presentation (copy on file in the City Clerk's Office and answered questions posed by members of Council.

The following City staff members commented and/or assisted answering questions:

- Ms. Karen Hamilton, Senior Assistant City Attorney
- Ms. Araceli Guerra, Managing Director of Internal Services
- Ms. Josette Flores, Senior Assistant City Attorney
- Ms. Mary Michel, Human Resources Assistant Director
- Mr. Robert Cortinas, Chief Financial Officer
- Mr. Tommy Gonzalez, City Manager
- Ms. Laura Cruz-Acosta, Strategic Communications Director

The following members of the public commented:

1. Mr. Tyler Grossman
2. Mr. Rick Bonart
3. Ms. Lisa Turner

Mayor Leeser and Representatives Svarzbein, Annelo, Hernandez, Molinar, Rodriguez, Salcido, and Rivera, commented.

#### **1<sup>ST</sup> MOTION**

Motion made by Representative Annelo, seconded by Representative Molinar and carried to **AMEND** the recommended ballot language for Section 2.2C as follows:

Should section 2.2C of the City Charter, relating to term limits, be amended to provide that a person who serves an unexpired term due to a council member vacancy be allowed to serve two full four-year terms, ~~regardless of whether it results in more than ten years~~ **“not to exceed ten years and six months”**?

AYES: Representatives Annelo, Molinar, Salcido, Rodriguez, and Rivera

NAYS: Representatives Svarzbein and Hernandez

ABSENT: Representative Lizarraga

#### **2<sup>ND</sup> MOTION**

Motion made by Representative Rodriguez, seconded by Representative Hernandez, and carried to **RECONSIDER** the amendment to Section 2.2C.

AYES: Representatives Svarzbein, Hernandez, Salcido, Rodriguez, and Rivera

NAYS: Representatives Annelo and Molinar

ABSENT: Representative Lizarraga

#### **3<sup>RD</sup> MOTION**

Motion made by Representative Annelo, seconded by Representative Molinar, to **AMEND** the recommended ballot language for Section 2.2C as follows:

Should section 2.2C of the City Charter, relating to term limits, be amended to provide that a person who serves an unexpired term due to a council member vacancy be allowed to serve two full four-year terms, ~~regardless of whether it results in more than ten years~~ **“not to exceed ten years and six months”**?

AYES: Representatives Svarzbein, Annelo, and Molinar

NAYS: Representatives Hernandez, Salcido, Rodriguez, and Rivera

ABSENT: Representative Lizarraga  
**THE MOTION FAILED.**

**4<sup>TH</sup> MOTION**

Motion made by Representative Rivera, seconded by Representative Salcido, and carried to **APPROVE** the recommended ballot language for Section 2.2C as follows:

Should section 2.2C of the City Charter, relating to term limits, be amended to provide that a person who serves an unexpired term due to a council member vacancy be allowed to serve two full four-year terms, regardless of whether it results in more than ten years?

AYES: Representatives Hernandez, Salcido, Rodriguez, and Rivera  
NAYS: Representatives Svarzbein, Annelo, and Molinar  
ABSENT: Representative Lizarraga

**5<sup>TH</sup> MOTION**

Motion made by Representative Annelo, seconded by Representative Salcido, and carried to **AMEND** a ballot proposition that would amend Section 3.1 as follows:

Each Representative shall have the discretion and sole authority to appoint and remove a Legislative Aide or Chief of Staff **“district office staff”**.

AYES: Representatives Svarzbein, Annelo, Salcido, and Rivera  
NAYS: Representatives Hernandez, Molinar, and Rodriguez  
ABSENT: Representative Lizarraga

**6<sup>TH</sup> MOTION**

Motion made by Representative Molinar, seconded by Representative Annelo, to **AMEND** a ballot proposition that would amend Section 3.1 as follows:

“Each City Representative may have two full-time employees, one as a Legislative Aide, and reports directly to the City Representative and with the authority to appoint and terminate”.

AYES: Representatives Annelo and Molinar  
NAYS: Representatives Svarzbein, Hernandez, Salcido, Rodriguez, and Rivera  
ABSENT: Representative Lizarraga  
**THE MOTION FAILED.**

**7<sup>TH</sup> MOTION**

Motion made by Representative Rivera, seconded by Representative Annelo, and unanimously carried to **APPROVE** only the following ballot proposition to amend Section 3.1 as follows:

Each Representative shall have the discretion and sole authority to appoint and remove a Legislative Aide or Chief of Staff **“district office staff”**.

AYES: Representatives Svarzbein, Annelo, Hernandez, Molinar, Salcido, Rodriguez, and  
Rivera  
NAYS: None  
ABSENT: Representative Lizarraga



**8<sup>TH</sup> MOTION**

Motion made by Representative Rivera, seconded by Representative Annello, and unanimously carried to **APPROVE** the recommended ballot language for Section 3.5A to read as follows:

- Should section 3.5A of the City Charter be amended to allow Council to reschedule meetings by resolution to allow for City holidays but shall hold no less than two regular meetings per month?
- Should section 3.5A of the City Charter be amended to allow the Mayor to cancel a meeting if necessary due to a Federal, State, or Local declared emergency?

AYES: Representatives Svarzbein, Annello, Hernandez, Molinar, Salcido, Rodriguez, and Rivera

NAYS: None

ABSENT: Representative Lizarraga

**9<sup>TH</sup> MOTION**

Motion made by Representative Annello, seconded by Representative Molinar, carried to **AMEND** a portion of the recommended amended language for Section 3.11 to eliminate the restriction on the type of ordinances for an initiative to read as follows:

“Any five registered voters, referred to in this section as the committee, may initiate an ordinance that complies with federal, state, and local law by filing with the City Clerk a statement that they intend to circulate a petition, ~~however, no ordinance may be initiated through this process regarding required appropriation or allocation of City funds, zoning or rezoning, levy of taxes, setting utility rates, purchase or sale of an interest in real property or granting a franchise.~~”

If the committee still wishes to seek adoption of the ordinance after Council fails to adopt, or does not agree to Council’s amendments, it will then have 90 calendar days after notice from the City Clerk to complete the petition by gathering signatures in the form required by state law, including but not limited to the original signature, printed name, residence address and date of birth or voter registration of a number of registered voters equal to at least five percent of the voters who voted in the last general City election or 20,000 voters whichever is smaller.

AYES: Representatives Svarzbein, Annello, Molinar, and Salcido

NAYS: Representatives Hernandez, Rodriguez, and Rivera

ABSENT: Representative Lizarraga

**10<sup>TH</sup> MOTION**

Motion made by Representative Salcido, seconded by Representative Rodriguez, and carried to **RECONSIDER** amendments to Section 3.11.

AYES: Representatives Hernandez, Salcido, Rodriguez, and Rivera

NAYS: Representatives Svarzbein, Annello and Molinar

ABSENT: Representative Lizarraga

**11<sup>TH</sup> MOTION**

Motion made by Representative Anello, seconded by Representative Molinar, carried to **AMEND** a portion of the recommended amended language for Section 3.11 to strike out the first paragraph and add a cap of 20,000 to the number of signatures required to read as follows:

~~“Any five registered voters, referred to in this section as the committee, may initiate an ordinance that complies with federal, state, and local law by filing with the City Clerk a statement that they intend to circulate a petition, however, no ordinance may be initiated through this process regarding required appropriation or allocation of City funds, zoning or rezoning, levy of taxes, setting utility rates, purchase or sale of an interest in real property or granting a franchise.”~~

If the committee still wishes to seek adoption of the ordinance after Council fails to adopt, or does not agree to Council’s amendments, it will then have 90 calendar days after notice from the City Clerk to complete the petition by gathering signatures in the form required by state law, including but not limited to the original signature, printed name, residence address and date of birth or voter registration of a number of registered voters equal to at least five percent of the voters who voted in the last general City election or 20,000 signatures whichever is smaller.

AYES: Representatives Svarzbein, Anello, and Molinar

NAYS: Representatives Hernandez, Rodriguez, Rivera and Mayor Leeser

ABSTAIN: Representative Salcido

ABSENT: Representative Lizarraga

**THE MAYOR BROKE THE TIE BY VOTING “NAY”. THE MOTION FAILED.**

**12<sup>TH</sup> MOTION**

Motion made by Representative Hernandez, seconded by Representative Rivera, and carried to **AMEND** a portion of the recommended amended language for Section 3.11 to include “or matters outside the City’s jurisdiction” to read as follows:

Any five registered voters, referred to in this section as the committee, may initiate an ordinance that complies with federal, state, and local law by filing with the City Clerk a statement that they intend to circulate a petition, however, no ordinance may be initiated through this process regarding required appropriation or allocation of City funds, zoning or rezoning, levy of taxes, setting utility rates, purchase or sale of an interest in real property, granting a franchise, or matters outside the City’s jurisdiction.

AYES: Representatives Hernandez, Rodriguez, Rivera, and Mayor Leeser

NAYS: Representatives Svarzbein, Anello, and Molinar

ABSTAIN: Representative Salcido

ABSENT: Representative Lizarraga

**THE MAYOR BROKE THE TIE BY VOTING “AYE”.**

**13<sup>TH</sup> MOTION**

Motion made by Representative Hernandez, seconded by Representative Rodriguez, to **APPROVE** the recommended ballot language and proposed amended language for Section 3.11 **AS AMENDED** to read as follows:

**Proposed ballot language:**

Should section 3.11 relating to the initiative petition of the City Charter be amended to remove the requirement for a second petition, and institute a process for the public to initiate a City ordinance?

**Proposed amended language:**

**Any five registered voters, referred to in this section as the committee, may initiate an ordinance that complies with federal, state, and local law by filing with the City Clerk a statement that they intend to circulate a petition, however, no ordinance may be initiated through this process regarding required appropriation or allocation of City funds, zoning or rezoning, levy of taxes, setting utility rates, purchase or sale of an interest in real property, or granting a franchise, or matters outside the City's jurisdiction. Such statements must include the names and addresses of the committee members, the full text of the proposed ordinance, and the designated lead committee member.**

**The City Clerk shall place the proposed Ordinance on the City Council Agenda for introduction within thirty days after receiving the statement, followed by a public hearing at the second reading. If City Council fails to adopt the ordinance or adopts it with amendments, the City Clerk will notify the committee through the lead committee member.**

**If the committee still wishes to seek adoption of the ordinance after Council fails to adopt, or does not agree to Council's amendments, it will then have 90 calendar days after notice from the City Clerk to complete the petition by gathering signatures in the form required by state law, including but not limited to the original signature, printed name, residence address and date of birth or voter registration** Whenever a number of registered voters who voted in the last general City election, ~~sign a~~ **The** petition **must** set forth the precise content of an **the** ordinance desired by the **petitioners**. ~~signers.~~

**Within thirty working days, the City Clerk shall review the petition to verify if it meets all requirements, and if authenticated with the required number of signatures,** ~~the Council~~ must place that ordinance on the agenda of a Council meeting to be held within thirty working days of the receipt, **authentication** by the City Clerk, of the petition bearing the authenticated names and addresses of the petitioners. Such an item shall be treated by the Council exactly as any other proposed ordinance.

~~Should an ordinance proposed by such petition not be enacted by the~~ If Council does not adopt, ~~or should it be enacted~~ **adopts the proposed ordinance** in an amended form, ~~a second petition, signed by a number of registered voters equal to at least five percent of the voters who voted in the last general City election,~~ may be submitted to the City Clerk and ~~that official shall have twenty working days in which to authenticate the signatures and thereafter must place the re-proposed ordinance on the ballot at the next~~ **citywide** general election specified in State law, if the proposal receives ~~and~~ the favorable vote of the majority of those voting in that election it shall thereupon become a City ordinance. The Council is not obligated to consider the same ordinance initiated by petition, or one that is substantially the same, more often than once in two years.

AYES: Representatives Hernandez, Rodriguez, and Rivera

NAYS: Representatives Svarzbein, Annello, Molinar, and Mayor Leeser  
ABSTAIN: Representative Salcido  
ABSENT: Representative Lizarraga

**THE MAYOR BROKE THE TIE BY VOTING "NAY". THE MOTION FAILED.**

**14<sup>TH</sup> MOTION**

Motion made by Representative Annello, seconded by Representative Rodriguez, and unanimously carried to **APPROVE** the recommended ballot language for Sections 3.9B, 3.10B, and 6.1-12 to read as follows:

Shall Sections 3.9B, 3.10B, 6.1-12 of the City Charter be amended to require submission to the qualified voters of the City to eliminate provisions that have become inoperative because they have superseded by state law; replace obsolete references, and update terminology to current legal usage?

AYES: Representatives Svarzbein, Annello, Hernandez, Molinar, Salcido, Rodriguez, and Rivera

NAYS: None

ABSENT: Representative Lizarraga

**15<sup>TH</sup> MOTION**

Motion made by Representative Hernandez, seconded by Representative Salcido, and unanimously carried to **APPROVE** the proposed amended language after discussion with pension office for Sections 6.13-11D to include the floor cap for City contributions as a separate ballot proposition to reads as follows:

Proposed amended language after discussion with pension office:

Firemen and Policemen Pension Fund of El Paso. The City shall continue to augment the Firemen and Policemen Pension Fund of El Paso in a manner consistent with the laws of Texas. To augment the Firemen and Policemen Pension Fund, the Council shall in each fiscal year beginning after February 1968, appropriate an amount equal to three times the amount paid into the fund by the participants therein. **Any change to the City's contribution shall comply with the relevant state Law;** ~~provided that the amount contributed by the City shall not exceed eighteen percent of the total amount expended for salaries of the participants;~~ provided further, however, that in the event age limits for participation in the pension fund, or any division of the fund, are increased as permitted by law and the raising of the age limits causes an increase in funding costs as determined by an actuary, the City shall appropriate an amount equal to such cost increase ~~notwithstanding that such increased appropriation may exceed eighteen percent of the total amount expended for salaries of the participants,~~ but such increased appropriation shall in no case exceed eighteen and **in an amount up to** one-half percent of the total amount expended for salaries of the participants.

Fireman and Policemen Pension Fund of El Paso. The City shall continue to augment the Firemen and Policemen Pension Fund of El Paso in a manner consistent with the laws of Texas. To augment the Fireman and Policemen Pension Fund, the Council shall in each fiscal year beginning after **November 2022,** ~~February, 1968~~ appropriate **no less than eighteen percent of the total amount expended for wages of the participants, and may increase this contribution rate as allowed by the relevant state law requirements based on a qualified actuary's report;** ~~an amount equal to three times the amount paid into the fund by the participants therein; provided that the amount contributed by the City shall not exceed eighteen~~

~~percent of the total amount expended for salaries of the participants;~~ provided further, however, that in the event age limits for participation in the pension fund, or any division of the fund, are increased as permitted by law and the raising of the age limits causes an increase in funding costs as determined by an actuary, the City shall appropriate an amount equal to such cost increase notwithstanding that such increased appropriation may exceed **the otherwise determined** ~~eighteen percent of the total amount expended for salaries of the participants, but such increased appropriation shall in no case exceed eighteen and one-half percent of the total amount expended for~~ **wages** salaries of the participants.

AYES: Representatives Svarzbein, Annello, Hernandez, Molinar, Salcido, Rodriguez, and Rivera

NAYS: None

ABSENT: Representative Lizarraga

#### **16<sup>TH</sup> MOTION**

Motion made by Representative Rodriguez, seconded by Representative Salcido, and carried to **APPROVE** the recommended ballot language for Section 3.18. to read as follows:

Should section 3.18 of the City Charter relating to Leases, Franchises, and Conveyances be amended to authorize Council to lease City-owned property for 40 years or less by Council resolution or ordinance?

AYES: Representatives Annello, Hernandez, Molinar, Salcido, Rodriguez, and Rivera

NAYS: Representative Svarzbein

ABSENT: Representative Lizarraga

#### **17<sup>TH</sup> MOTION**

Motion made by Representative Rodriguez, seconded by Mayor Pro Tempore Svarzbein, and carried to **AMEND** the recommended ballot language for Section 4.1B to include an effective date of the first meeting in 2025 to read as follows:

Should sections 1.2, 3.5E, 3.6, 4.1B, 4.3, and 7.3 of the City Charter be amended to authorize the Mayor to vote on City Council agenda items and remove the Mayor's tie-breaking and veto capacity **beginning with the first meeting in 2025?**

AYES: Representatives Svarzbein, Annello, Hernandez, Salcido, Rodriguez, and Rivera

NAYS: Representative Molinar

ABSENT: Representative Lizarraga

#### **18<sup>TH</sup> MOTION**

Motion made by Representative Annello, seconded by Representative Molinar, to **AMEND** the recommended ballot language for Section 4.1B to have the amendment to Section 3.5E (Mayor's veto power) as a separate ballot item:

AYES: Representatives Annello, Molinar, and Rivera

NAYS: Representatives Svarzbein, Hernandez, Salcido, and Rodriguez

ABSENT: Representative Lizarraga

**THE MOTION FAILED.**

**19<sup>TH</sup> MOTION**

Motion made by Representative Rodriguez, seconded by Representative Salcido, and carried to **RECONSIDER** the previous motion related to Section 3.5E.

AYES: Representatives Svarzbein, Hernandez, Salcido, Rodriguez, and Rivera

NAYS: Representative Annelo and Molinar

ABSENT: Representative Lizarraga

**20<sup>TH</sup> MOTION**

Motion made by Representative Annelo, seconded by Representative Molinar, to **AMEND** the recommended ballot language for Section 4.1B to have the amendment to Section 3.5E (Mayor's veto power) as a separate ballot item:

AYES: Representatives Annelo and Molinar

NAYS: Representatives Svarzbein, Hernandez, Salcido, Rodriguez, and Rivera

ABSENT: Representative Lizarraga

**THE MOTION FAILED.**

**21<sup>ST</sup> MOTION**

Motion made by Mayor Pro Tempore Svarzbein, seconded by Representative Rivera, and carried to **APPROVE** the recommended ballot language for Sections 4.1B, 1.2, 3.5E, 3.6, 4.18, 4.3 and 7.3D **AS AMENDED** to read as follows:

Should sections 1.2, 3.5E, 3.6, 4.1B, 4.3, and 7.3 of the City Charter be amended to authorize the Mayor to vote on City Council agenda items and remove the Mayor's tie-breaking and veto capacity beginning with the first meeting in 2025?

AYES: Representatives Svarzbein, Hernandez, Salcido, Rodriguez, and Rivera

NAYS: Representatives Annelo and Molinar

ABSENT: Representative Lizarraga

**22<sup>ND</sup> MOTION**

Motion made by Mayor Pro Tempore Svarzbein, seconded by Representative Hernandez, and carried to **DENY** the recommended ballot language for Section 4.1B below:

Should section 4.1B of the City Charter be amended to clarify that the Mayor will represent the City in intergovernmental relationships as established by City Council legislative priorities?

AYES: Representatives Svarzbein, Hernandez, Salcido, Rodriguez, and Rivera

NAYS: Representative Molinar

ABSENT: Representative Lizarraga

NOT PRESENT FOR THE VOTE: Representative Annelo

**23<sup>RD</sup> MOTION**

Motion made by Representative Rodriguez, seconded by Representative Hernandez, and carried to **APPROVE** the recommended ballot language for Sections 6.1-4 to read as follows:

Should 6.1-4 be amended by the City to allow for the appointment of Civil Service Commissioners that reflect the diversity of the community and City workforce?

AYES: Representatives Hernandez, Salcido, Rodriguez, and Rivera  
NAYS: Representative Svarzbein, Annello, and Molinar  
ABSENT: Representative Lizarraga

**24<sup>TH</sup> MOTION**

Motion made by Representative Rodriguez, seconded by Representative Salcido, to **APPROVE** the recommended ballot language for Section 6.5-2 below:

Should Section 6.5-2 regarding the rule of five be deleted to allow for more flexibility in City employee promotions?

AYES: Representatives Hernandez, Salcido and Rodriguez  
NAYS: Representative Svarzbein, Annello, Molinar, and Rivera  
ABSENT: Representative Lizarraga  
**THE MOTION FAILED.**

**25<sup>TH</sup> MOTION**

Motion made by Representative Hernandez, seconded by Representative Salcido, and carried to **APPROVE** the recommended ballot language for Sections 6.7-1 and 6.8-1 to read as follows:

Should Sections 6.7-1 and 6.8-1 be amended to establish policies and procedures for the promotion of City employees?

AYES: Representatives Hernandez, Salcido, Rodriguez, and Rivera  
NAYS: Representative Svarzbein, Annello, and Molinar  
ABSENT: Representative Lizarraga

**26<sup>TH</sup> MOTION**

Motion made by Representative Hernandez, seconded by Representative Rivera, and carried to **APPROVE** a ballot proposition that would amend Section 6.2 to align the role of the Commission Recorder for the Civil Service Commission to other similarly situated City employees.

AYES: Representatives Hernandez, Salcido, Rodriguez, and Rivera  
NAYS: Representative Svarzbein, Annello, and Molinar  
ABSENT: Representative Lizarraga

Motion made, seconded, and unanimously carried to **SUSPEND THE RULES OF ORDER** to allow Rick Bonart, member of the public, to speak for a second time.

**27<sup>TH</sup> MOTION**

Motion made by Representative Hernandez, seconded by Representative Rodriguez, to **APPROVE** the language for Section 3.11 as originally recommended by the Ad Hoc Charter Advisory Committee without any amendments:

**Proposed ballot language:**

Should section 3.11 relating to the initiative petition of the City Charter be amended to remove the requirement for a second petition, and institute a process for the public to initiate a City ordinance?

Proposed amended language:

Any five registered voters, referred to in this section as the committee, may initiate an ordinance that complies with federal, state, and local law by filing with the City Clerk a statement that they intend to circulate a petition, however, no ordinance may be initiated through this process regarding required appropriation or allocation of City funds, zoning or rezoning, levy of taxes, setting utility rates, purchase or sale of an interest in real property, or granting a franchise. Such statements must include the names and addresses of the committee members, the full text of the proposed ordinance, and the designated lead committee member.

The City Clerk shall place the proposed Ordinance on the City Council Agenda for introduction within thirty days after receiving the statement, followed by a public hearing at the second reading. If City Council fails to adopt the ordinance or adopts it with amendments, the City Clerk will notify the committee through the lead committee member.

If the committee still wishes to seek adoption of the ordinance after Council fails to adopt, or does not agree to Council's amendments, it will then have 90 calendar days after notice from the City Clerk to complete the petition by gathering signatures in the form required by state law, including but not limited to the original signature, printed name, residence address and date of birth or voter registration Whenever a number of registered voters who voted in the last general City election, sign a The petition must set forth the precise content of an the ordinance desired by the petitioners. ~~signers.~~

Within thirty working days, the City Clerk shall review the petition to verify if it meets all requirements, and if authenticated with the required number of signatures, the Council must place that ordinance on the agenda of a Council meeting to be held within thirty working days of the receipt, authentication by the City Clerk, of the petition bearing the authenticated names and addresses of the petitioners. Such an item shall be treated by the Council exactly as any other proposed ordinance.

~~Should an ordinance proposed by such petition not be enacted by the~~ If Council does not adopt, or should it be enacted adopts the proposed ordinance in an amended form, a second petition, signed by a number of registered voters equal to at least five percent of the voters who voted in the last general City election, may be submitted to the City Clerk and that official shall have twenty working days in which to authenticate the signatures and thereafter must place the re-proposed ordinance on the ballot at the next citywide general election specified in State law, if the proposal receives a the favorable vote of the majority of those voting in that election it shall thereupon become a City ordinance. The Council is not obligated to consider the same ordinance initiated by petition, or one that is substantially the same, more often than once in two years.

AYES: Representatives Salcido, Rodriguez, and Rivera  
NAYS: Representatives Svarzbein, Annelo, Hernandez, and Molinar  
ABSENT: Representative Lizarraga  
**THE MOTION FAILED.**

## **28<sup>TH</sup> MOTION**

Motion made by Representative Hernandez, seconded by Representative Rodriguez, and carried to **RECONSIDER** the proposed language for Section 3.11.

AYES: Representatives Annelo, Hernandez, Salcido, Rodriguez, and Rivera



NAYS: Representative Svarzbein and Molinar  
ABSENT: Representative Lizarraga

**29<sup>TH</sup> MOTION**

Motion made by Mayor Pro Tempore Svarzbein, seconded by Representative Annello, to **AMEND** a portion of the recommended language for Section 3.11 by deleting the types of ordinances that may be initiated through the initiative process regarding required appropriation of City funds, purchase or sale of an interest in real property and **CHANGE** the number of days for gathering signatures from 90 to 180 days to read as follows.

**Proposed amended language:**

“Any five registered voters, referred to in this section as the committee, may initiate an ordinance that complies with federal, state, and local law by filing with the City Clerk a statement that they intend to circulate a petition, however, no ordinance may be initiated through this process regarding ~~required appropriation or allocation of City funds,~~ zoning or rezoning, levy of taxes, setting utility rates, ~~purchase or sale of an interest in real property,~~ or granting a franchise. Such statements must include the names and addresses of the committee members, the full text of the proposed ordinance, and the designated lead committee member.”

“If the committee still wishes to seek adoption of the ordinance after Council fails to adopt, or does not agree to Council’s amendments, it will then have ~~90~~ **180** calendar days after notice from the City Clerk to complete the petition by gathering signatures in the form required by state law, including but not limited to the original signature, printed name, residence address and date of birth or voter registration.”

AYES: Representatives Svarzbein, Annello, and Molinar  
NAYS: Representatives Hernandez, Salcido, Rodriguez, and Rivera  
ABSENT: Representative Lizarraga  
**THE MOTION FAILED.**

**30<sup>TH</sup> MOTION**

Motion made by Representative Salcido, seconded by Representative Rodriguez, and carried to **AMEND** a portion of the recommended language for Section 3.11 to **CHANGE** the number of days for gathering signatures from 90 to 180 days to read as follows:

“If the committee still wishes to seek adoption of the ordinance after Council fails to adopt, or does not agree to Council’s amendments, it will then have ~~90~~ **180** calendar days after notice from the City Clerk to complete the petition by gathering signatures in the form required by state law, including but not limited to the original signature, printed name, residence address and date of birth or voter registration.”

AYES: Representatives Annello, Hernandez, Salcido, Rodriguez, and Rivera  
NAYS: Representatives Svarzbein and Molinar  
ABSENT: Representative Lizarraga

**31<sup>ST</sup> MOTION**

Motion made by Representative Hernandez, seconded by Representative Rodriguez, and carried to **APPROVE** the recommended ballot language and amended language for Section

3.11 **AS AMENDED** to read as follows.

**Proposed ballot language:**

Should section 3.11 relating to the initiative petition of the City Charter be amended to remove the requirement for a second petition, and institute a process for the public to initiate a City ordinance?

**Proposed amended language:**

**Any five registered voters, referred to in this section as the committee, may initiate an ordinance that complies with federal, state, and local law by filing with the City Clerk a statement that they intend to circulate a petition, however, no ordinance may be initiated through this process regarding required appropriation or allocation of City funds, zoning or rezoning, levy of taxes, setting utility rates, purchase or sale of an interest in real property, or granting a franchise. Such statements must include the names and addresses of the committee members, the full text of the proposed ordinance, and the designated lead committee member.**

**The City Clerk shall place the proposed Ordinance on the City Council Agenda for introduction within thirty days after receiving the statement, followed by a public hearing at the second reading. If City Council fails to adopt the ordinance or adopts it with amendments, the City Clerk will notify the committee through the lead committee member.**

**If the committee still wishes to seek adoption of the ordinance after Council fails to adopt, or does not agree to Council's amendments, it will then have 90 180 calendar days after notice from the City Clerk to complete the petition by gathering signatures in the form required by state law, including but not limited to the original signature, printed name, residence address and date of birth or voter registration** Whenever a number of registered voters who voted in the last general City election, **sign a The** petition **must** set forth the precise content of an **the** ordinance desired by the **petitioners**. signers.

**Within thirty working days, the City Clerk shall review the petition to verify if it meets all requirements, and if authenticated with the required number of signatures,** the Council must place that ordinance on the agenda of a Council meeting to be held within thirty working days of the receipt, **authentication** by the City Clerk, of the petition bearing the authenticated names and addresses of the petitioners. Such an item shall be treated by the Council exactly as any other proposed ordinance.

~~Should an ordinance proposed by such petition not be enacted by the~~ If Council does not adopt, or should it be enacted **adopts the proposed ordinance** in an amended form, a second petition, signed by a number of registered voters equal to at least five percent of the voters who voted in the last general City election, may be submitted to the City Clerk and that official shall have twenty working days in which to authenticate the signatures and thereafter must place the re-proposed ordinance on the ballot at the next **citywide** general election specified in State law, if the proposal receives **s** the favorable vote of the majority of those voting in that election it shall thereupon become a City ordinance. The Council is not obligated to consider the same ordinance initiated by petition, or one that is substantially the same, more often than once in two years.

AYES: Representatives Hernandez, Salcido, Rodriguez, and Rivera

NAYS: Representatives Svarzbein, Anello, and Molinar

ABSENT: Representative Lizarraga

.....  
The Work Session was **RECESSED** at 12:35 p.m. for lunch.

The Work Session was **RECONVENED** at 1:04 p.m.

The Work Session was **RECESSED** at 3:40 p.m. on July 18, 2022 until July 19, 2022.

The Work Session was **RECONVENED** at 2:16 p.m. on July 19, 2022 with all members of Council present, except Representative Molinar, who requested to be excused.

.....  
7. Discussion and action to review and amend the employment agreement for the City Attorney and City Manager in alignment with the City's Strategic Plan Goal of setting the standard for sound governance and fiscal management.

**1<sup>ST</sup> MOTION**

Motion made by Representative Hernandez, seconded by Representative Annello, and unanimously carried to **TABLE** the item until July 19, 2022.

AYES: Representatives Svarzbein, Annello, Hernandez, Molinar, Salcido, Rodriguez, and Rivera  
NAYS: None  
ABSENT: Representative Lizarraga

**2<sup>ND</sup> MOTION**

Motion made by Alternate Mayor Pro Tempore Lizarraga, seconded by Representative Salcido, and unanimously carried that the City Council **RETIRE** into **EXECUTIVE SESSION** at 2:17 p.m. on July 19, 2022 pursuant to Section 3.5A of the El Paso City Charter and the Texas Government Code, Sections 551.071 - 551.089 to discuss the executive session items:

Section 551.071 CONSULTATION WITH ATTORNEY  
Section 551.074 PERSONNEL MATTERS

AYES: Representatives Svarzbein, Annello, Hernandez, Salcido, Rodriguez, Rivera, and Lizarraga  
NAYS: None  
ABSENT: Representative Molinar

**3<sup>RD</sup> MOTION**

Motion made by Representative Annello, seconded by Representative Salcido, and unanimously carried to **ADJOURN** the Executive Session at 5:35 p.m. on July 19, 2022 and **RECONVENE** the meeting of the City Council. \*at which time motions were made:

AYES: Representatives Svarzbein, Annello, Hernandez, Molinar, Salcido, Rivera, and Lizarraga  
NAYS: None  
NOT PRESENT FOR THE VOTE: Representative Rodriguez  
ABSENT: Representative Molinar

**4<sup>TH</sup> MOTION**

Motion made by Mayor Pro Tempore Svarzbein, seconded by Representative Rivera, and unanimously carried that outside counsel is authorized to **CONTINUE** discussions with the City

Manager and City Attorney, through their respective lawyers, regarding the employment agreement, to come back in two weeks, and that City Council authorizes the City Attorney to continue to retain outside counsel for executive employment related matters.

AYES: Representatives Svarzbein, Annelo, Hernandez, Molinar, Salcido, Rodriguez, Rivera, and Lizarraga

NAYS: None

ABSENT: Representative Molinar

**5<sup>TH</sup> MOTION**

Motion made by Representative Rodriguez, seconded by Representative Rivera, and unanimously carried to **RECONSIDER** the item.

**6<sup>TH</sup> MOTION**

Motion made by Representative Rodriguez, seconded by Representative Rivera, and unanimously carried to **AMEND THE ITEM** by adding “to return in two weeks:

AYES: Representatives Svarzbein, Annelo, Hernandez, Molinar, Salcido, Rodriguez, Rivera, and Lizarraga

NAYS: None

ABSENT: Representative Molinar

**7<sup>TH</sup> AND FINAL MOTION**

Motion made by Representative Rodriguez, seconded by Representative Lizarraga, and unanimously carried to **APPROVE, AS AMENDED**, that outside counsel is authorized to continue discussions with the City Manager and City Attorney, through their respective lawyers, regarding the employment agreements, to come back before City Council in two weeks, and that City Council authorizes the City Attorney to continue to retain outside counsel for executive employment related matters.

AYES: Representatives Svarzbein, Annelo, Hernandez, Molinar, Salcido, Rodriguez, Rivera, and Lizarraga

NAYS: None

ABSENT: Representative Molinar

.....  
**ADJOURN**

Motion made by Representative Rivera, seconded by Representative Lizarraga and unanimously carried to **ADJOURN** the Work Session at 5:42 p.m. on July 19, 2022

AYES: Representatives Svarzbein, Annelo, Hernandez, Salcido, Rodriguez, Rivera, and Lizarraga

NAYS: None

ABSENT: Representative Molinar

.....  
APPROVED AS TO CONTENT:

\_\_\_\_\_  
Laura D. Prine, City Clerk



El Paso, TX

300 N. Campbell  
El Paso, TX

Legislation Text

---

**File #: 22-967, Version: 1**

---

**CITY OF EL PASO, TEXAS  
LEGISTAR AGENDA ITEM SUMMARY FORM**

**DISTRICT, DEPARTMENT, CONTACT INFORMATION:**

*Please choose District and Department from drop down menu. Please post exactly as example below.  
No Title's, No emails. Please use ARIAL 10 Font.*

**AGENDA LANGUAGE:**

*This is the language that will be posted to the agenda. Please use ARIAL 11 Font.*

REQUEST TO EXCUSE ABSENT CITY COUNCIL MEMBERS



---

File #: 22-952, Version: 1

---

**CITY OF EL PASO, TEXAS  
LEGISTAR AGENDA ITEM SUMMARY FORM**

**DISTRICT, DEPARTMENT, CONTACT INFORMATION:**

*Please choose District and Department from drop down menu. Please post exactly as example below.  
No Title's, No emails. Please use ARIAL 10 Font.*

**District 3**

Airport, Sam Rodriguez, (915) 212-7301

**AGENDA LANGUAGE:**

*This is the language that will be posted to the agenda. Please use ARIAL 11 Font.*

That the City Manager be authorized to sign an Underground Electrical and Transformer Pad Easement for six (6) Easements, hereinafter referred to as ("Easement"), to accommodate an electrical transmission line to provide electrical power to property in the vicinity of the El Paso International Airport, said easement more particularly described as: A portion of Lot 1, Block 11, Butterfield Trail Industrial Park Unit Two, City of El Paso, El Paso County, Texas.

**CITY OF EL PASO, TEXAS  
AGENDA ITEM  
DEPARTMENT HEAD'S SUMMARY FORM**

**AGENDA DATE:** August 2, 2022  
**PUBLIC HEARING DATE:** N/A

**CONTACT PERSON(S) NAME AND PHONE NUMBER:** Sam Rodriguez, P.E., CM, Director of Aviation  
915-212-7301

**DISTRICT(S) AFFECTED:** 3

**STRATEGIC GOAL:** No. 7: Enhance and Sustain El Paso's Infrastructure Network

**SUBGOAL:**

**SUBJECT:**

That the City Manager be authorized to sign an Underground Electrical and Transformer Pad Easement for six (6) easements, hereinafter referred to as ("easement"), to accommodate an electrical transmission line to provide electrical power to property in the vicinity of the El Paso International Airport, said easement more particularly described as: A portion of Lot 1, Block 11, Butterfield Trail Industrial Park Unit Two, City of El Paso, El Paso County, Texas.

**BACKGROUND / DISCUSSION:**

The easement is needed to provide electric service to the Airport tenant located at 25 Butterfield Trail Boulevard.

**PRIOR COUNCIL ACTION:**

N/A

**AMOUNT AND SOURCE OF FUNDING:**

N/A

**HAVE ALL AFFECTED DEPARTMENTS BEEN NOTIFIED?**  YES  NO

**PRIMARY DEPARTMENT:** Aviation  
**SECONDARY DEPARTMENT:**

\*\*\*\*\*REQUIRED AUTHORIZATION\*\*\*\*\*

**DEPARTMENT HEAD:**



(If Department Head Summary Form is Initiated by Purchasing, client department should sign also)

**RESOLUTION**

**BE IT RESOLVED BY THE CITY COUNCIL OF THE CITY OF EL PASO:**

That the City Manager be authorized to sign an Underground Electrical and Transformer Pad Easement for six (6) easements, hereinafter referred to as ("easement"), to accommodate an electrical transmission line to provide electrical power to property in the vicinity of the El Paso International Airport, said easement more particularly described as:

A portion of Lot 1, Block 11, Butterfield Trail Industrial Park Unit Two, City of El Paso, El Paso County, Texas.

ADOPTED THIS \_\_\_\_\_ DAY OF \_\_\_\_\_, 2022.

THE CITY OF EL PASO

\_\_\_\_\_  
Oscar Leeser  
Mayor

ATTEST:

\_\_\_\_\_  
Laura D. Prine  
City Clerk

APPROVED AS TO FORM:

\_\_\_\_\_  
Leslie B. Jean-Pierre  
Assistant City Attorney

APPROVED AS TO CONTENT:

\_\_\_\_\_  
Samuel Rodriguez, P.E.  
Director of Aviation



THE STATE OF TEXAS           §  
                                           §                                           **UNDERGROUND ELECTRICAL AND**  
 COUNTY OF EL PASO           §                                           **TRANSFORMER PAD EASEMENT**

For and in consideration of the sum of One Dollar and No/100 (\$1.00) and other good and valuable consideration, the receipt of which is hereby acknowledged, the City of El Paso (Grantor) grants unto El Paso Electric Company (Grantee), its successors and assigns, the right and privilege to enter and erect, relocate, construct, operate, remove, inspect, access, and maintain an underground electric system consisting of transformers (conventional or pad mount), ducts, conduits, fixtures, manholes, handholes, vaults, and any other usual appurtenances pertaining thereto, and underground crossings with all necessary cables, lines, conduit, wires pertaining thereto, with the right of access, ingress, and egress, thereto for the installation, construction, operation, inspection, repair, maintenance, replacement, renewal or removal thereof, for the distribution of electricity, for any and all purposes for which same is or may hereafter be used, over or under, upon, and along the areas identified in Exhibit "A" and Exhibit "B" attached hereto and incorporated herein for all purposes, said six (6) areas being in the following described premises in El Paso, El Paso County, Texas, to wit:

**A portion of Lot 1, Block 11, Butterfield Trail Industrial Park Unit Two,  
 City of El Paso, El Paso County, Texas.**

These six (6) easements herein referred to as ("easement") are more fully illustrated in Exhibit "A" and Exhibit "B".

With the right to trim any trees and flora around said electrical facilities so as to keep the electrical facilities cleared and to do anything proper and necessary to operate and maintain same.

This easement shall be for the term of Grantee's franchise and any extension and renewal thereof by the Grantor. In accepting this easement, Grantee agrees that Grantor shall have the power at any time to require Grantee to remove and abate, at Grantee's expense, any installation or structure that is dangerous to life or property and that Grantor shall have the power at any time to require Grantee to change the route and position of its poles, lines, conduits or other construction at Grantee's expense when the El Paso City Council (the "City Council") shall find, by resolution, that such change is necessary in the closing, opening or relocation of streets or alleys, or water or sewer lines, the changing of grade of streets or alleys, the construction and maintenance of public improvements, the construction of private buildings, the construction or use of driveways or under other conditions which the City Council shall find necessary. Provided, however, that Grantee shall be entitled to be paid for its costs and expense of any relocation, raising or lowering of its wires or cables required by Grantor if such expenses or costs are reimbursable or payable to Grantee or Grantor by the State of Texas, the United States, or any agency or subdivision of either whether directly or indirectly. Grantor shall use its best reasonable efforts to consult and confer with Grantee before requiring any such relocation or raising or lowering of its lines or cables, with a view to accomplishing the result reasonably and economically.

In accepting this grant, Grantee agrees that it will replace or repair, as reasonable, landscaping and paving if disturbed by Grantee's construction, maintenance or repairs of or to its facilities in and upon such

easement. Grantee shall promptly restore to as good condition as before working thereon, and to the reasonable satisfaction of the Grantor all streets excavated by it. Grantee may, from time to time and as may be required by prudent utility practices in connection with the construction, maintenance, or repair of its facilities, restrict access to or interfere with the use of Grantor's structures(s) or tangible personal property located on or in the vicinity of the easement. In such event, Grantee shall endeavor to provide Grantor reasonable written notice of any such restriction or interference and shall use commercially reasonable efforts to coordinate its activities with Grantor so as to minimize the duration and extent of such restriction or interference. The preceding sentence notwithstanding, certain events or circumstances may occur or arise that require Grantee to take immediate action to address imminent public safety concerns, the integrity of Grantee's facilities or system, or the reliability of service provided by Grantee. Under such or similar exigencies, Grantee shall provide Grantor notice of any restrictions or interference as soon as reasonably practicable, and shall use commercially reasonable efforts to minimize the duration and extent of such restriction or interference. Grantee agrees to call for utility spotting by a third party prior to any excavation by Grantee in the easement.

Grantor reserves the right to full use and enjoyment of said property except for the purposes herein granted. Grantor agrees not to erect permanent structures or obstruct access in, over, or under Grantee's facilities.

Grantor will not be held responsible for any damage to Grantee's underground facilities from excessive erosion due to flood run-off.

Should Grantee abandon the easement, then the easement hereinabove described shall revert to Grantor or its successors and assigns. Such abandonment shall be conclusively presumed following non-use by the Grantee for one year and with use not being resumed within sixty (60) days following receipt of notice of abandonment from Grantor to Grantee, and on such abandonment, Grantee will then execute any and all necessary documents to evidence such abandonment.

Grantee shall maintain the surface over the length and width of the easement to the satisfaction, as reasonable, of Grantor and in accordance with all applicable laws, ordinances, regulations, and City Code provisions.

WITNESS THE FOLLOWING SIGNATURES AND SEAL on the dates entered below.

GRANTOR:  
THE CITY OF EL PASO

\_\_\_\_\_  
Tomás González,  
City Manager

APPROVED AS TO FORM:

\_\_\_\_\_  
Leslie B. Jean-Pierre  
Assistant City Attorney

APPROVED AS TO CONTENT:

\_\_\_\_\_  
Samuel Rodríguez, P.E.  
Director of Aviation

ACKNOWLEDGMENT

THE STATE OF TEXAS §  
                                          §  
COUNTY OF EL PASO §

This instrument was acknowledged before me on the \_\_\_\_\_ day of \_\_\_\_\_, 2022 by Tomás González as City Manager of the City of El Paso.

\_\_\_\_\_  
Notary Public in and for  
the State of Texas

The above instrument, together with all conditions thereto is hereby accepted on the date entered below.

GRANTEE:  
EL PASO ELECTRIC COMPANY

By: \_\_\_\_\_  
Printed Name: Aurea D. Garcia  
Title: Supervisor - Land Management

ACKNOWLEDGMENT

THE STATE OF TEXAS §  
                                          §  
COUNTY OF EL PASO §

This instrument was acknowledged before me on the \_\_\_\_\_ day of \_\_\_\_\_, 2022\_ by Aurea D. Garcia as Supervisor - Land Management of El Paso Electric Company, on behalf of the El Paso Electric Company, a Texas corporation.

\_\_\_\_\_  
Notary Public in and for  
the State of Texas

### EPIA Addendum to EPEC Easement - FAA

Pursuant to Federal Aviation Administration Order 1400.11, effective August 27, 2013, and because the described premises comprising the easement are located at the El Paso International Airport which is subject to regulation by, among others, the U.S. Federal Aviation Administration, the parties specifically agree to the following:

1. A. The Grantee for itself, its successors in interest and assigns, as a part of the consideration hereof, does hereby covenant and agree, as a covenant running with the land, that (1) in the event facilities are constructed, maintained, or otherwise operated on the property described in this easement for a purpose for which a Federal Aviation Administration activity, facility, or program is extended or for another purpose involving the provision of similar services or benefits, Grantee will maintain and operate such facilities and services in compliance with all requirements imposed by the Acts and Regulations set out in Federal Aviation Administration Order 1400.11, Appendix 4, as same may be amended from time to time (the "Acts and Regulations") such that no person on the grounds of race, color, or national origin, will be excluded from participation in, denied the benefits of, or be otherwise subjected to discrimination in the use of said facilities.

B. With respect to the easement, in the event of breach of any of the above nondiscrimination covenants, Grantor will have the right to terminate the easement and to enter or re-enter and repossess said land and the facilities thereon (excepting Grantee's electrical facilities, which shall be removed by Grantee as soon as reasonably practical upon notice by Grantor), and hold the same as if said easement had never been made or issued. [See FAA Order 1400.11, Appendix C of Appendix 4]

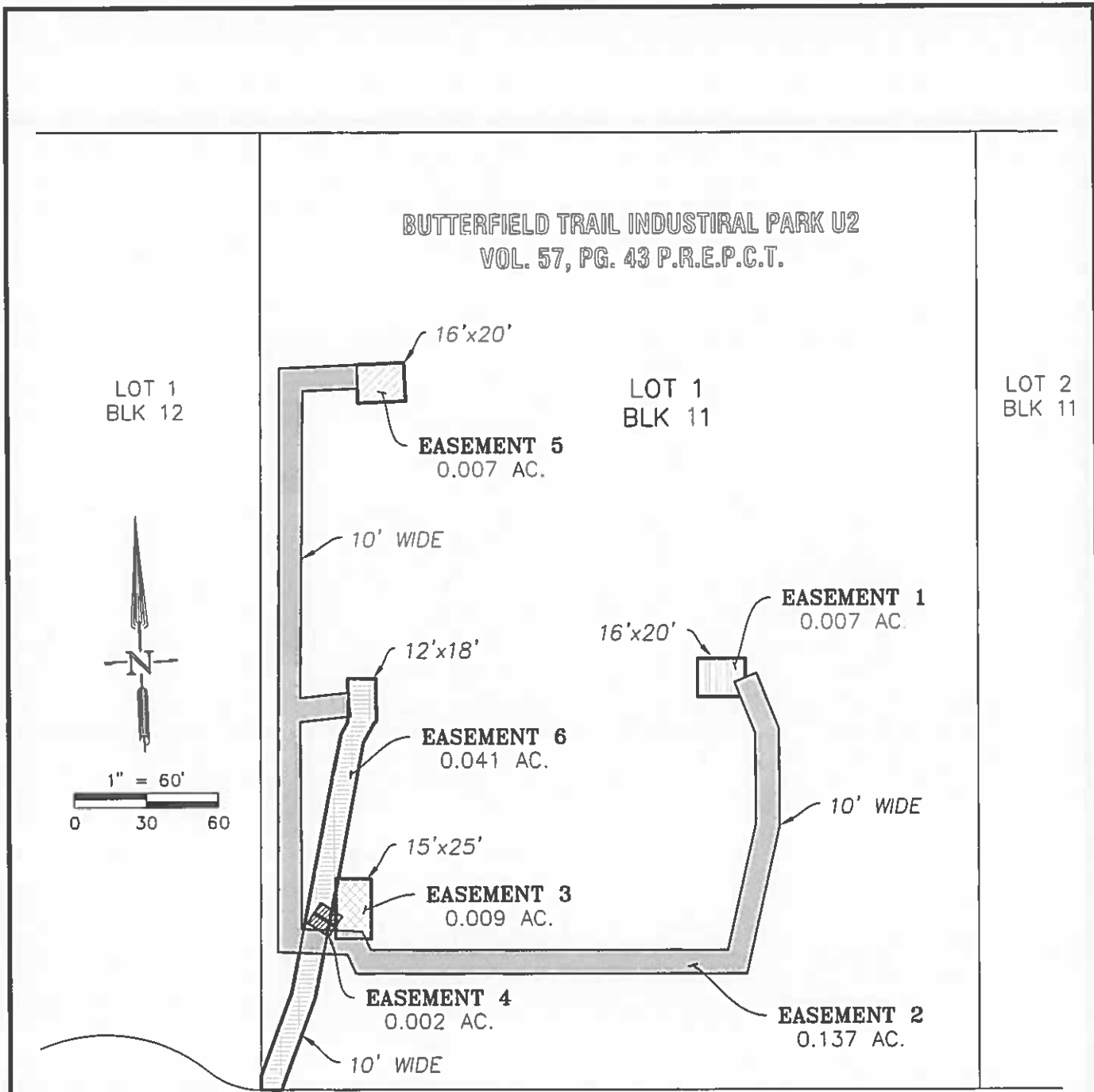
2. A. The Grantee for itself, its successors in interest and assigns, as a part of the consideration hereof, does hereby covenant and agree, as a covenant running with the land, that (1) no person on the ground of race, color, or national origin, will be excluded from participation in, denied the benefits of, or be otherwise subjected to discrimination in the use of said facilities, (2) that in the construction of any improvements on, over, or under such land, and the furnishing of services thereon, no person on the ground of race, color, or national origin, will be excluded from participation in, denied the benefits of, or otherwise be subjected to discrimination, (3) that the Grantee will use the premises in compliance with all other requirements imposed by or pursuant to the Acts and Regulations.

B. With respect to the easement, in the event of breach of any of the above nondiscrimination covenants, Grantor will have the right to terminate the easement and to enter or re-enter and repossess said land and the facilities thereon (excepting Grantee's electrical facilities, which shall be removed by Grantee as soon as reasonably practical upon notice by Grantor), and hold the same as if said easement had never been made or issued. [See FAA Order 1400.11, Appendix D of Appendix 4]

3. A. During the term of this easement, Grantee for itself, its successors in interest, and assigns, as a part of the consideration hereof, agrees to comply with the following non-discrimination statutes and authorities; including but not limited to:

- Title VI of the Civil Rights Act of 1964 (42 U.S.C. § 2000d et seq., 78 stat. 252), (prohibits discrimination on the basis of race, color, national origin);
- 49 CFR part 21 (Non-discrimination In Federally-Assisted Programs of The Department of Transportation—Effectuation of Title VI of The Civil Rights Act of 1964);
- The Uniform Relocation Assistance and Real Property Acquisition Policies Act of 1970, (42 U.S.C. § 4601), (prohibits unfair treatment of persons displaced or whose property has been acquired because of Federal or Federal-aid programs and projects);
- Section 504 of the Rehabilitation Act of 1973, (29 U.S.C. § 794 et seq.), as amended, (prohibits discrimination on the basis of disability); and 49 CFR part 27;
- The Age Discrimination Act of 1975, as amended, (42 U.S.C. § 6101 et seq.), (prohibits discrimination on the basis of age);
- Airport and Airway Improvement Act of 1982, (49 USC § 471, Section 47123), as amended, (prohibits discrimination based on race, creed, color, national origin, or sex);
- The Civil Rights Restoration Act of 1987, (PL 100-209), (Broadened the scope, coverage and applicability of Title VI of the Civil Rights Act of 1964, The Age Discrimination Act of 1975 and Section 504 of the Rehabilitation Act of 1973, by expanding the definition of the terms —programs or activities to include all of the programs or activities of the Federal-aid recipients, sub-recipients and contractors, whether such programs or activities are Federally funded or not);
- Titles II and III of the Americans with Disabilities Act of 1990, which prohibit discrimination on the basis of disability in the operation of public entities, public and private transportation systems, places of public accommodation, and certain testing entities (42 U.S.C. §§ 12131 – 12189) as implemented by Department of Transportation regulations at 49 CFR parts 37 and 38;
- The Federal Aviation Administration’s Non-discrimination statute (49 U.S.C. § 47123) (prohibits discrimination on the basis of race, color, national origin, and sex);
- Executive Order 12898, Federal Actions to Address Environmental Justice in Minority Populations and Low-Income Populations, which ensures discrimination against minority populations by discouraging programs, policies, and activities with disproportionately high and adverse human health or environmental effects on minority and low-income populations;
- Executive Order 13166, Improving Access to Services for Persons with Limited English Proficiency, and resulting agency guidance, national origin discrimination includes discrimination because of limited English proficiency (LEP). Grantee shall take reasonable steps to ensure that LEP persons have meaningful access to its programs (70 Fed. Reg. at 74087 to 74100);
- Title IX of the Education Amendments of 1972, as amended, which prohibits discrimination because of sex in education programs or activities (20 U.S.C. 1681 et seq).

B. In the event of breach of any of the covenants in this section 3, Grantor shall have the rights and remedies set forth in sections 1 and 2 above, in addition to all other rights and remedies available to it under applicable law. [FAA Order 1400.11, Appendix E of Appendix 4]



**BUTTERFIELD TRAIL BLVD.**

DT053032

PAGE 1 OF 1

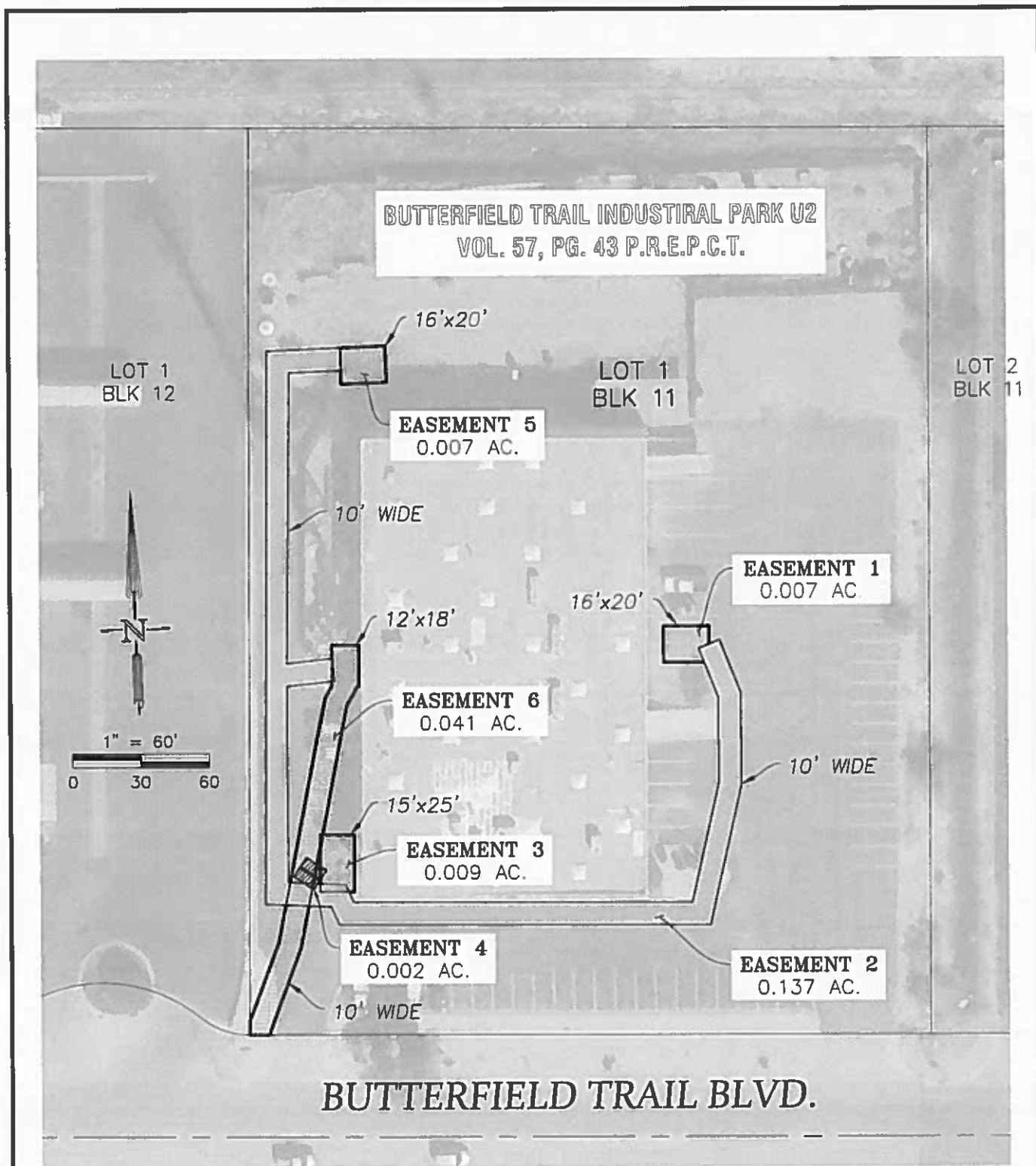
**HUITT - ZOLLARS INC.**

5822 Cromo Drive, Suite 210  
 El Paso, TX 79912  
 PH. 915-587-4339  
 Tx. Firm No. 10025603  
 www.huilt-zollars.com

PROJECT: 25 BUTTERFIELD TRAIL
JOB #: R315453.01
DATE: JUNE 06, 2022
SCALE: 1"=60'
DRAWN: JZ
CHECKED: CMW
PATH: C:\proj\R315453.01-EPEC-DT053032 25 Butterfield Trail Survey\CAD 3D 2022

**EASEMENT INDEX  
 OF 25 BUTTERFIELD TRAIL BLVD.  
 WITHIN LOT 1, BLOCK 11  
 BUTTERFIELD TRAIL INDUSTRIAL PARK  
 UNIT TWO, CITY OF EL PASO,  
 EL PASO COUNTY, TEXAS**

Exhibit A Index (Page 2 of 2)



BUTTERFIELD TRAIL INDUSTRIAL PARK U2  
VOL. 57, PG. 43 P.R.E.P.C.T.

LOT 1  
BLK 12

LOT 1  
BLK 11

LOT 2  
BLK 11



EASEMENT 5  
0.007 AC.

EASEMENT 1  
0.007 AC.

EASEMENT 6  
0.041 AC.

EASEMENT 3  
0.009 AC.

EASEMENT 4  
0.002 AC.

EASEMENT 2  
0.137 AC.

BUTTERFIELD TRAIL BLVD.

DT053032

PAGE 1 OF 1

**HUITT-ZOLLARS INC.**

5822 Cromo Drive, Suite 210  
El Paso, TX 79912  
PH. 915-587-4339  
Tx. Firm No. 10025603  
www.huilt-zollars.com

PROJECT: 25 BUTTERFIELD TRAIL  
JOB #: R315453.01  
DATE: JUNE 06, 2022  
SCALE: 1"=60'  
DRAWN: JZ  
CHECKED: CMW  
PATH: G:\proj\R315453.01-EPEC-DT053032-25 Butterfield Trail Survey\CML 3D 2022

EASEMENT INDEX  
OF 25 BUTTERFIELD TRAIL BLVD.  
WITHIN LOT 1, BLOCK 11  
BUTTERFIELD TRAIL INDUSTRIAL PARK  
UNIT TWO, CITY OF EL PASO,  
EL PASO COUNTY, TEXAS



## Exhibit B (Page 1 of 24)

## Easement 1

**EXHIBIT "A"**

DT053032

HZI PROJECT No. R315453.01  
 0.007 ACRE ELECTRIC EASEMENT  
 OUT OF LOT 1, BLOCK 11  
 BUTTERFIELD TRAIL  
 INDUSTRIAL PARK UNIT TWO  
 CITY OF EL PASO  
 EL PASO COUNTY, TEXAS

That certain parcel of land, being a portion of Lot 1, Block 11, Butterfield Trail Industrial Park Unit Two, as recorded in Volume 57, Page 43, Plat records of El Paso County, Texas, within the City of El Paso, El Paso County, Texas, and being more particularly described by Metes and Bounds as follows (record dimensions shown in parenthesis ( ) are recited herein to reference Subdivision Plat of said Butterfield Trail Industrial Park Unit Two):

**COMMENCING** at a brass disk in hand hole found for city monument at the centerline intersection of Butterfield Trail Boulevard and Butterfield Circle, both being a 90 foot wide right-of-way per said Butterfield Trail Industrial Park Unit Two, said Point of Commencement having modified Texas Coordinate System (central zone, U.S. survey feet, NAD83) ground coordinates of N=10,676,995.07, E=415,198.61;

**THENCE** N 02°05'52" E, leaving said centerline, a distance of 45.00 feet to the northerly right-of-way line of said Butterfield Trail Boulevard;

**THENCE** N 87°54'08" W, continuing with said northerly right-of-way line, a distance of 72.47 feet (record: N 87°54'08" W) to a 5/8 inch rebar with cap, not legible found for the southeast corner of Lot 1, Block 11, of said Butterfield Trail Industrial Park Unit Two;

**THENCE** N 02°05'52" E, with the east line of said Lot 1, a distance of 179.85 feet (record: N 02°05'52" E), from which a found 1 inch aluminum cap stamped 5152 at the northeast corner of said Lot 1 bears N 02°05'52" E, a distance of 219.36 feet (record: N 02°05'52" E);

**THENCE** N 87°54'08" W leaving said easterly lot line, across said Lot 1, a distance of 97.50 feet to the **POINT OF BEGINNING**, being the northeast corner of the herein described parcel, and having modified Texas Coordinate System (central zone, U.S. survey feet, NAD83) ground coordinates of N=10,677,225.99, E=415,036.98;

**THENCE** continuing over and across said Lot 1, with the east, south, west and north lines of the herein described parcel, the following four (4) courses and distances:

1. S 01°58'11" W, a distance of 16.00 feet to the southeast corner of the herein described parcel,
2. N 88°01'49" W, a distance of 20.00 feet to the southwest corner of the herein described parcel,
3. N 01°58'11" E, a distance of 16.00 feet to the northwest corner of the herein described parcel, and
4. S 88°01'49" E, a distance of 20.00 feet to the **POINT OF BEGINNING**, containing 0.007 acres or 320 square feet of land.

Exhibit B (Page 2 of 24)

Easement 1

EXHIBIT "A"

DT053032

HZI PROJECT No. R315453.01  
0.007 ACRE ELECTRIC EASEMENT  
OUT OF LOT 1, BLOCK 11  
BUTTERFIELD TRAIL  
INDUSTRIAL PARK UNIT TWO  
CITY OF EL PASO  
EL PASO COUNTY, TEXAS

Note:

Distances and coordinates shown on this survey are surface values (US Survey Feet) based on a scaling of the Texas Coordinate System, Central Zone, NAD 83, by a ground scale factor of 1.00023100, at N=0, E=0. All bearings (except parenthetical record bearings) shown on this survey are state plane grid bearings, derived from GPS observations. A plat of survey on two letter size sheets is attached hereto, and made a part of this description for all purposes, and must be recorded with this description.



Christian M. Wegmann, Texas RPLS# 6794  
Huitt-Zollars, Inc.  
5822 Cromo Drive, Suite 210  
El Paso, Texas 79912  
Firm Registration No. 10025603  
Phone 915-587-4339



REV. 7-7-22

Exhibit B (Page 3 of 24)

Easement 1

FND. 1/2" RB.  
W/ PLASTIC CAP  
ILLEGIBLE

FND. 1' ALUMINUM CAP  
STAMPED #5152

BUTTERFIELD TRAIL INDUSTRIAL PARK U2  
VOL. 57, PG. 43 P.R.E.P.C.T.



1" = 60'  
0 30 60

LOT 1  
BLK 12

POB  
N=10,677,225.99  
E=415,036.98

LOT 1  
BLK 11

N87°54'08"W  
97.50'

LOT 2  
BLK 11

N02°05'52"E 219.36'  
(TIE)  
(R: N02°05'52"E)

PROP. ELEC.  
EASMNT  
0.007 AC  
320 SQ. FT.

FND. 5/8" RB.  
W/ PLASTIC CAP  
ILLEGIBLE

(R: N02°05'52"E)  
N02°05'52"E  
179.85'

LOT LINE

(R: N87°54'08"W)  
N87°54'08"W  
72.47'

BUTTERFIELD TRAIL BLVD.

(90' ROW)

N02°05'52"E  
45.00'

POC  
FND. CITY MONUMENT  
N=10,676,995.07  
E=415,198.61

BUTTERFIELD CIR.

(90' ROW)

DT053032

PAGE 3 OF 4

HUITT - ZOLLARS INC.

5822 Cromo Drive, Suite 210  
El Paso, TX 79912

PH. 915-587-4339  
Tx. Firm No. 10025603  
www.huilt-zollars.com

PROJECT: 25 BUTTERFIELD TRAIL

JOB #: R315453.01

DATE: MAY, 2022

SCALE: 1"=100'

DRAWN: JZ

CHECKED: CMW

PATH: G:\proj\R315453\01-EPEC-DT053032\_25 Butterfield  
Trail\Survey\CMA\_30\_2022

0.007 ACRES (320 SQ. FT.)  
A PORTION OF LOT 1, BLOCK 11  
BUTTERFIELD TRAIL INDUSTRIAL PARK  
UNIT TWO  
CITY OF EL PASO,  
EL PASO COUNTY, TEXAS

Exhibit B (Page 4 of 24)

Easement 1

SURVEY NOTES

1. BASIS OF BEARING IS THE TEXAS COORDINATE SYSTEM OF 1983 (NAD83), CENTRAL ZONE (4203).
2. DISTANCES AND COORDINATES SHOWN HEREON ARE SURFACE VALUES, USING A GROUND SCALE FACTOR OF 1.000231, SCALED AT N=0, E=0.
3. BEARINGS AND DISTANCES SHOWN IN PARENTHESIS ( ) ARE LISTED TO RECITE RECORD DIMENSIONS PER THE FOLLOWING DOCUMENTS: BUTTERFIELD TRAIL INDUSTRIAL PARK UNIT TWO RECORDED IN VOL. 57, PG. 43, P.R.E.P.C.T.
4. THIS PLAT OF SURVEY SHALL ACCOMPANY THE ATTACHED METES AND BOUNDS DESCRIPTION FOR RECORDING PURPOSES.

LINE TABLE		
LINE No.	DIRECTION	LENGTH
L1	S01° 58' 11"W	16.00'
L2	N88° 01' 49"W	20.00'
L3	N01° 58' 11"E	16.00'
L4	S88° 01' 49"E	20.00'

LEGEND

- FND. SURVEY MARKER (AS NOTED)
- △ CALCULATED CORNER
- D.R.E.P.C.T. DEED RECORDS OF EL PASO COUNTY, TEXAS
- P.R.E.P.C.T. PLAT RECORDS OF EL PASO COUNTY, TEXAS
- POC POINT OF COMMENCEMENT
- POB POINT OF BEGINNING
- BK. BOOK
- PG. PAGE
- ROW RIGHT OF WAY
- DOC. DOCUMENT
- FND. FOUND

SURVEYOR'S CERTIFICATION

I, CHRISTIAN M. WEGMANN, A TEXAS REGISTERED PROFESSIONAL LAND SURVEYOR, HEREBY CERTIFY THAT THIS SURVEY WAS PERFORMED UNDER MY SUPERVISION, AND THAT IT IS BASED ON AN ACTUAL FIELD SURVEY PERFORMED ON THE GROUND.

CHRISTIAN M. WEGMANN  
REGISTERED PROFESSIONAL LAND SURVEYOR  
TEXAS REGISTRATION NO. 6794



REV. 7-7-22

DT053032

PAGE 4 OF 4

**HUITT - ZOLLARS INC.**

5822 Cromo Drive, Suite 210  
El Paso, TX 79912  
PH. 915-587-4339  
Tx. Firm No. 10025603  
www.huitt-zollars.com

PROJECT: 25 BUTTERFIELD TRAIL
JOB #: R315453.01
DATE: MAY, 2022
SCALE: N/A
DRAWN: JZ
CHECKED: CMW
PATH: C:\proj\R315453.01-EPEC-DT053032 25 Butterfield Trail Survey\CMA_30_2022

0.007 ACRES (320 SQ. FT.)  
A PORTION OF LOT 1, BLOCK 11  
BUTTERFIELD TRAIL INDUSTRIAL PARK  
UNIT TWO  
CITY OF EL PASO,  
EL PASO COUNTY, TEXAS

## Exhibit B (Page 5 of 24)

## Easement 2

## EXHIBIT "A"

DT053032

HZI PROJECT No. R315453.01  
 0.137 ACRE ELECTRIC EASEMENT  
 OUT OF LOT 1, BLOCK 11  
 BUTTERFIELD TRAIL  
 INDUSTRIAL PARK UNIT TWO  
 CITY OF EL PASO  
 EL PASO COUNTY, TEXAS

That certain 0.137 acre parcel of land, being 10 feet in width, 5 feet on each side of the herein described centerlines, situated within Lot 1, Block 11, Butterfield Trail Industrial Park Unit Two, recorded in Volume 57, Page 43, Plat records of El Paso County, Texas, within the City of El Paso, El Paso County, Texas, said centerlines being more particularly described as follows (record dimensions shown in parenthesis ( ) are recited herein to reference Subdivision Plat of said Butterfield Trail Industrial Park Unit Two):

**COMMENCING** at a brass disk in hand hole found for city monument at the centerline intersection of Butterfield Trail Boulevard and Butterfield Circle, both being a 90 foot wide right-of-way per said Butterfield Trail Industrial Park Unit Two, said Point of Commencement having modified Texas Coordinate System (central zone, U.S. survey feet, NAD83) ground coordinates of N=10,676,995.07, E=415,198.61;

**THENCE** N 02°05'52" E, leaving said centerline, a distance of 45.00 feet to the northerly right-of-way line of said Butterfield Trail Boulevard;

**THENCE** N 87°54'08" W, continuing with said northerly right-of-way line, a distance of 72.47 feet (record: N 87°54'08" W) to a 5/8 inch rebar with cap, not legible found for the southeast corner of Lot 1, Block 11, of said Butterfield Trail Industrial Park Unit Two;

**THENCE** N 02°05'52" E, with the east line of said Lot 1, a distance of 171.85 feet (record: N 02°05'52" E), from which a found 1 inch aluminum cap stamped 5152 at the northeast corner of said Lot 1 bears N 02°05'52" E, a distance of 227.36 feet (record: N 02°05'52" E);

**THENCE** N 87°54'08" W, leaving said easterly line, across said Lot 1, a distance of 97.49 feet to the **POINT OF BEGINNING**, having modified Texas Coordinate System (central zone, U.S. survey feet, NAD83) ground coordinates of N=10,677,217.99, E=415,036.71;

**THENCE** continuing over and across said Lot 1, with the centerlines of the herein described parcel, the following nine (9) courses and distances:

1. S 19°48'05" E, a distance of 24.21 feet,
2. S 01°53'57" W, a distance of 38.79 feet,
3. S 14°45'26" W, a distance of 58.75 feet,
4. N 87°52'02" W, a distance of 156.79,
5. N 23°14'42" W, a distance of 8.65 feet,
6. N 85°26'28" W, a distance of 26.94 feet,
7. N 01°55'38" E, a distance of 95.60 feet to a point, hereby being designated as "Point "A" for further use in this description,
8. N 02°42'58" E, a distance of 138.29 feet, and

Exhibit B (Page 6 of 24)

Easement 2

EXHIBIT "A"

DT053032

HZI PROJECT No. R315453.01  
0.137 ACRE ELECTRIC EASEMENT  
OUT OF LOT 1, BLOCK 11  
BUTTERFIELD TRAIL  
INDUSTRIAL PARK UNIT TWO  
CITY OF EL PASO  
EL PASO COUNTY, TEXAS

- 9. N 89°35'36" E, a distance of 27.52 feet to the **POINT OF TERMINATION**, from which a 1 inch Aluminum Cap Stamped "5152" found for the northeast corner of said Lot 1 bears N 70°42'35" E, a distance of 279.12 feet, said Point of Termination having modified Texas Coordinate System (central zone, U.S. survey feet, NAD83) ground coordinates of N=10,677,349.42, E=414,879.01;

**TOGETHER WITH:**

**BEGINNING** at formerly described "**Point A**", having modified Texas Coordinate System (central zone, U.S. survey feet, NAD83) ground coordinates of N=10,677,211.09, E=414,844.93;

**THENCE** N 85°42'51" E a distance of 25.40 feet to the **POINT OF TERMINATION**, from which a 1 inch Aluminum Cap Stamped "5152" found for the northeast corner of said Lot 1 bears N 49°58'13" E, a distance of 355.48 feet, said Point of Termination having modified Texas Coordinate System (central zone, U.S. survey feet, NAD83) ground coordinates of N=10,677,212.99, E=414,870.26;

Notes:

- 1. Distances and coordinates shown on this survey are surface values (US Survey Feet) based on a scaling of the Texas Coordinate System, Central Zone, NAD 83, by a ground scale factor of 1.00023100, at N=0, E=0.
- 2. All bearings (except parenthetical record bearings) shown on this survey are state plane grid bearings, derived from GPS observations.
- 3. A plat of survey on two letter size sheets is attached hereto, and made a part of this description for all purposes, and must be recorded with this description.
- 4. Subject parcel is 10 foot wide based on the described centerlines. Sidelines of this centerline description shall be extended or shortened to end perpendicular to the Point of Beginning and Points of Termination
- 5. Total area of subject parcel: 0.137 acres or 5,959 square feet

  
 Christian M. Wegmann, Texas RPLS# 6794  
 Huitt-Zollars, Inc.  
 5822 Cromo Drive, Suite 210  
 El Paso, Texas 79912  
 Firm Registration No. 10025603  
 Phone 915-587-4339

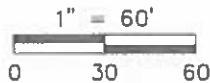
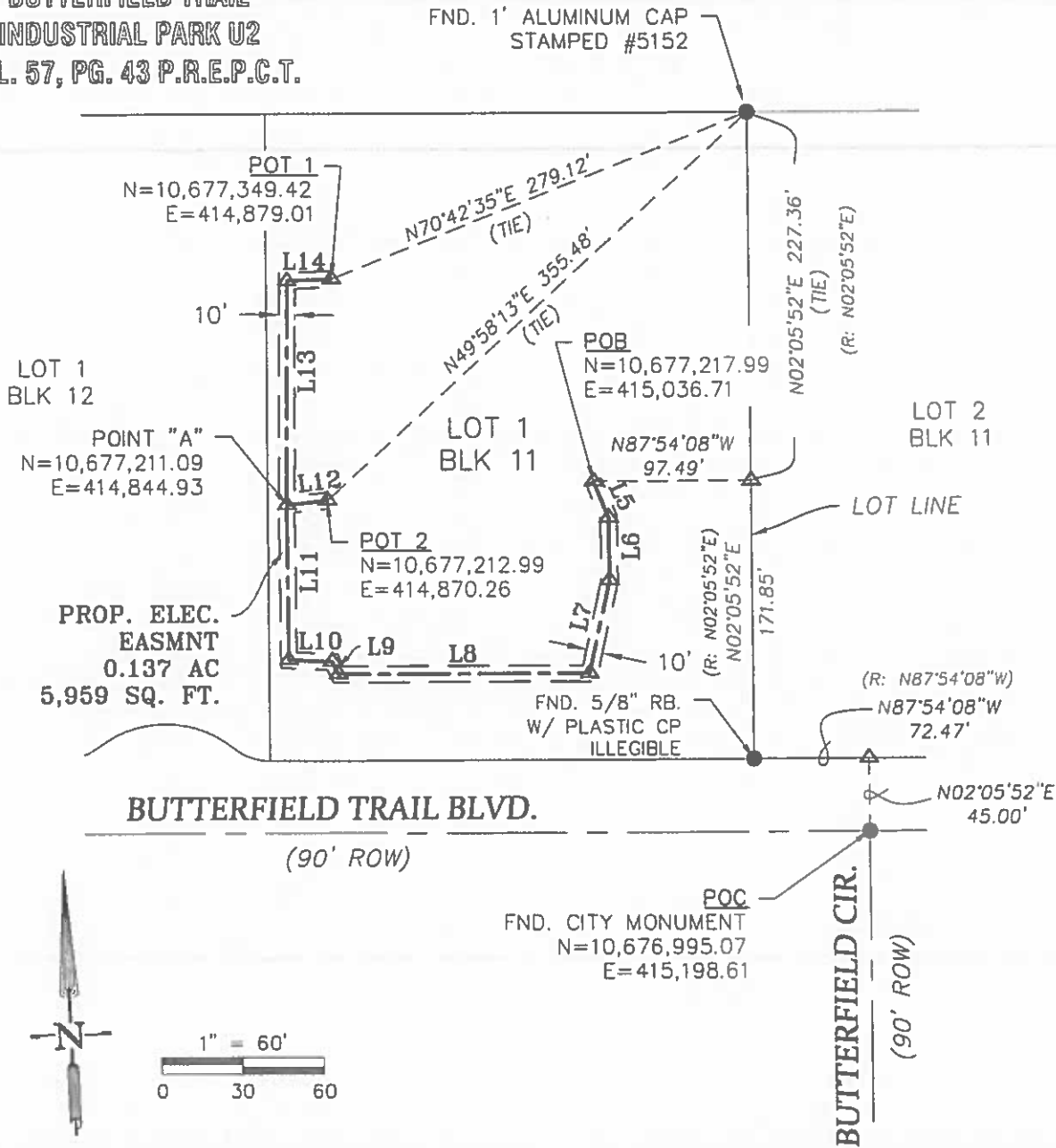


Rev 7-7-22

Exhibit B (Page 7 of 24)

Easement 2

BUTTERFIELD TRAIL  
INDUSTRIAL PARK U2  
VOL. 57, PG. 43 P.R.E.P.C.T.



DT053032

PAGE 3 OF 4

HUITT-ZOLLARS INC.

5822 Cromo Drive, Suite 210  
El Paso, TX 79912  
PH. 915-587-4339  
Tx. Firm No. 10025603  
www.huitt-zollars.com

PROJECT: 25 BUTTERFIELD TRAIL
JOB #: R315453.01
DATE: MAY, 2022
SCALE: 1"=100'
DRAWN: JZ
CHECKED: CMW
PATH: C:\proj\R315453.01-EPEC-DT053032 25 Butterfield Trail\Survey\CML_30_2022

0.137 ACRES (5,959 SQ. FT.)  
A PORTION OF LOT 1, BLOCK 11  
BUTTERFIELD TRAIL INDUSTRIAL PARK  
UNIT TWO  
CITY OF EL PASO,  
EL PASO COUNTY, TEXAS

Exhibit B (Page 8 of 24)

Easement 2

SURVEY NOTES

1. BASIS OF BEARING IS THE TEXAS COORDINATE SYSTEM OF 1983 (NAD83), CENTRAL ZONE (4203).
2. DISTANCES AND COORDINATES SHOWN HEREON ARE SURFACE VALUES, USING A GROUND SCALE FACTOR OF 1.000231, SCALED AT N=0, E=0.
3. BEARINGS AND DISTANCES SHOWN IN PARENTHESIS ( ) ARE LISTED TO RECITE RECORD DIMENSIONS PER THE FOLLOWING DOCUMENTS: BUTTERFIELD TRAIL INDUSTRIAL PARK UNIT TWO RECORDED IN VOL. 57, PG. 43, P.R.E.P.C.T.
4. THIS PLAT OF SURVEY SHALL ACCOMPANY THE ATTACHED METES AND BOUNDS DESCRIPTION FOR RECORDING PURPOSES.

LEGEND


- FND. SURVEY MARKER (AS NOTED)
- △ CALCULATED CORNER
- D.R.E.P.C.T. DEED RECORDS OF EL PASO COUNTY, TEXAS
- P.R.E.P.C.T. PLAT RECORDS OF EL PASO COUNTY, TEXAS
- POC POINT OF COMMENCEMENT
- POB POINT OF BEGINNING
- POT POINT OF TERMINATION
- BK. BOOK
- PG. PAGE
- ROW RIGHT OF WAY
- DOC. DOCUMENT
- FND. FOUND

LINE TABLE

LINE No.	DIRECTION	LENGTH
L5	S19° 48' 05"E	24.21'
L6	S01° 53' 57"W	38.79'
L7	S14° 45' 26"W	58.75'
L8	N87° 52' 02"W	156.79'
L9	N23° 14' 42"W	8.65'
L10	N85° 26' 28"W	26.94'
L11	N01° 55' 38"E	95.60'
L12	N85° 42' 51"E	25.40'
L13	N02° 42' 58"E	138.29'
L14	N89° 35' 36"E	27.52'

SURVEYOR'S CERTIFICATION

I, CHRISTIAN M. WEGMANN, A TEXAS REGISTERED PROFESSIONAL LAND SURVEYOR, HEREBY CERTIFY THAT THIS SURVEY WAS PERFORMED UNDER MY SUPERVISION, AND THAT IT IS BASED ON AN ACTUAL FIELD SURVEY PERFORMED ON THE GROUND.

  
 CHRISTIAN M. WEGMANN  
 REGISTERED PROFESSIONAL LAND SURVEYOR  
 TEXAS REGISTRATION NO. 6794



REV 7-17-22

DT053032

PAGE 4 OF 4

**HUITT - ZOLLARS INC.**  
 5822 Cromo Drive, Suite 210  
 El Paso, TX 79912  
 PH. 915-587-4339  
 Tx. Firm No. 10025603  
 www.huitt-zollars.com

PROJECT: 25 BUTTERFIELD TRAIL  
 JOB #: R315453.01  
 DATE: MAY, 2022  
 SCALE: N/A  
 DRAWN: JZ  
 CHECKED: CMW  
 PATH: C:\proj\R315453.01-EPEC-DT053032 25 Butterfield Trail Survey\CML\_3D\_2022

0.137 ACRES (5,959 SQ. FT.)  
 A PORTION OF LOT 1, BLOCK 11  
 BUTTERFIELD TRAIL INDUSTRIAL PARK  
 UNIT TWO  
 CITY OF EL PASO,  
 EL PASO COUNTY, TEXAS



## Exhibit B (Page 9 of 24)

## Easement 3

**EXHIBIT "A"**

DT053032

HZI PROJECT No. R315453.01  
 0.009 ACRE ELECTRIC EASEMENT  
 OUT OF LOT 1, BLOCK 11  
 BUTTERFIELD TRAIL  
 INDUSTRIAL PARK UNIT TWO  
 CITY OF EL PASO  
 EL PASO COUNTY, TEXAS

That certain parcel of land, being a portion of Lot 1, Block 11, Butterfield Trail Industrial Park Unit Two, as recorded in Volume 57, Page 43, Plat records of El Paso County, Texas, within the City of El Paso, El Paso County, Texas, and being more particularly described by Metes and Bounds as follows (record dimensions shown in parenthesis ( ) are recited herein to reference Subdivision Plat of said Butterfield Trail Industrial Park Unit Two):

**COMMENCING** at a brass disk in hand hole found for city monument at the centerline intersection of Butterfield Trail Boulevard and Butterfield Circle, both being a 90 foot wide right-of-way per said Butterfield Trail Industrial Park Unit Two, said Point of Commencement having modified Texas Coordinate System (central zone, U.S. survey feet, NAD83) ground coordinates of N=10,676,995.07, E=415,198.61;

**THENCE** N 02°05'52" E, leaving said centerline, a distance of 45.00 feet to the northerly right-of-way line of said Butterfield Trail Boulevard;

**THENCE** N 87°54'08" W, continuing with said northerly right-of-way line, a distance of 72.47 feet (record: N 87°54'08" W) to a 5/8 inch rebar with cap, not legible found for the southeast corner of Lot 1, Block 11, of said Butterfield Trail Industrial Park Unit Two;

**THENCE** N 02°05'52" E, with the east line of said Lot 1, a distance of 63.05 feet (record: N 02°05'52" E), from which a found 1 inch aluminum cap stamped "5152" at the northeast corner of said Lot 1 bears N 02°05'52" E, a distance of 336.16 feet (record: N 02°05'52" E);

**THENCE** N 87°54'08" W leaving said easterly lot line, across said Lot 1, a distance of 254.56 feet to the **POINT OF BEGINNING**, being the southeast corner of the herein described parcel, and having modified Texas Coordinate System (central zone, U.S. survey feet, NAD83) ground coordinates of N=10,677,115.02, E=414,875.76;

**THENCE** continuing over and across said Lot 1, with the south, west, north and east lines of the herein described parcel, the following four (4) courses and distances:

1. N 87°52'49" W, a distance of 15.00 feet to the southwest corner of the herein described parcel,
2. N 02°07'11" E, a distance of 25.00 feet to the northwest corner of the herein described parcel,
3. S 87°52'49" E, a distance of 15.00 feet to the northeast corner of the herein described parcel, and
4. S 02°07'11" W, a distance of 25.00 feet to the **POINT OF BEGINNING**, containing 0.009 acres or 375 square feet of land.

## Exhibit B (Page 10 of 24)

## Easement 3

EXHIBIT "A"

DT053032

HZI PROJECT No. R315453.01  
0.009 ACRE ELECTRIC EASEMENT  
OUT OF LOT 1, BLOCK 11  
BUTTERFIELD TRAIL  
INDUSTRIAL PARK UNIT TWO  
CITY OF EL PASO  
EL PASO COUNTY, TEXAS

Note:

Distances and coordinates shown on this survey are surface values (US Survey Feet) based on a scaling of the Texas Coordinate System, Central Zone, NAD 83, by a ground scale factor of 1.00023100, at N=0, E=0. All bearings (except parenthetical record bearings) shown on this survey are state plane grid bearings, derived from GPS observations. A plat of survey on two letter size sheets is attached hereto, and made a part of this description for all purposes, and must be recorded with this description.

  
Christian M. Wegmann, Texas RPLS# 6794  
Huitt-Zollars, Inc.  
5822 Cromo Drive, Suite 210  
El Paso, Texas 79912  
Firm Registration No. 10025603  
Phone 915-587-4339

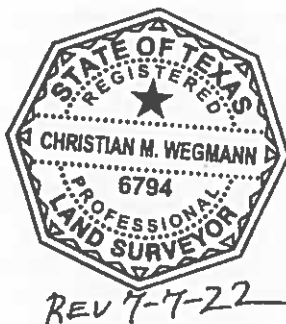
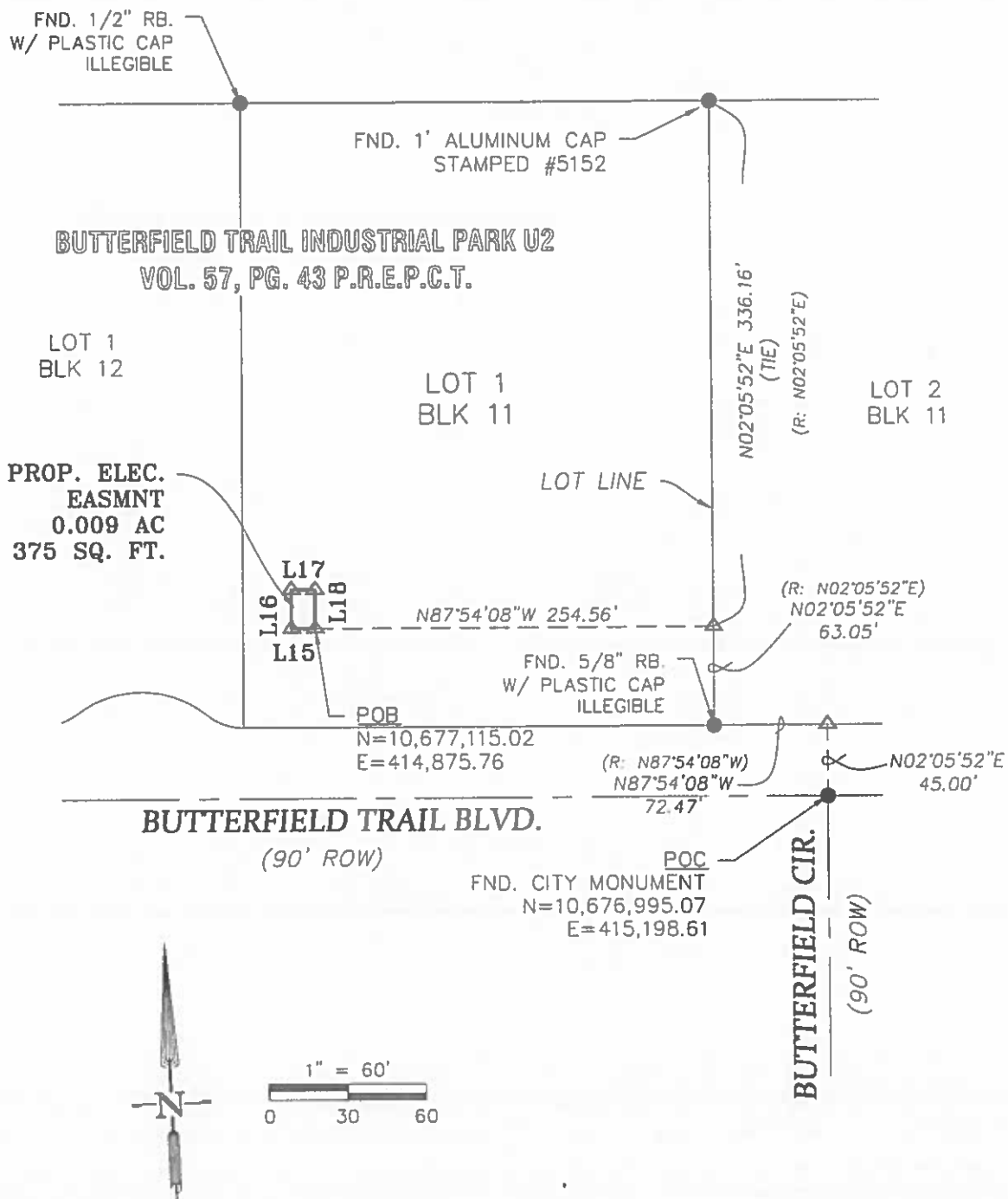


Exhibit B (Page 11 of 24)

Easement 3



DT053032

PAGE 3 OF 4

HUITT - ZOLLARS INC.

5822 Cromo Drive, Suite 210  
 El Paso, TX 79912  
 PH. 915-587-4339  
 Tx. Firm No. 10025603  
 www.huitt-zollars.com

PROJECT: 25 BUTTERFIELD TRAIL
JOB #: R315453.01
DATE: MAY, 2022
SCALE: 1"=100'
DRAWN: JZ
CHECKED: CMW
PATH: C:\proj\R315453.01-EPEC-01053032 25 Butterfield Trail\Survey\CMW_30_2022

0.009 ACRES (375 SQ. FT.)  
 A PORTION OF LOT 1, BLOCK 11  
 BUTTERFIELD TRAIL INDUSTRIAL PARK  
 UNIT TWO  
 CITY OF EL PASO,  
 EL PASO COUNTY, TEXAS

Exhibit B (Page 12 of 24)

Easement 3

**SURVEY NOTES**

1. BASIS OF BEARING IS THE TEXAS COORDINATE SYSTEM OF 1983 (NAD83), CENTRAL ZONE (4203).
2. DISTANCES AND COORDINATES SHOWN HEREON ARE SURFACE VALUES, USING A GROUND SCALE FACTOR OF 1.000231, SCALED AT N=0, E=0.
3. BEARINGS AND DISTANCES SHOWN IN PARENTHESIS ( ) ARE LISTED TO RECITE RECORD DIMENSIONS PER THE FOLLOWING DOCUMENTS: BUTTERFIELD TRAIL INDUSTRIAL PARK UNIT TWO RECORDED IN VOL. 57, PG. 43, P.R.E.P.C.T.
4. THIS PLAT OF SURVEY SHALL ACCOMPANY THE ATTACHED METES AND BOUNDS DESCRIPTION FOR RECORDING PURPOSES.

**LEGEND**

- FND. SURVEY MARKER (AS NOTED)
- △ CALCULATED CORNER
- D.R.E.P.C.T. DEED RECORDS OF EL PASO COUNTY, TEXAS
- P.R.E.P.C.T. PLAT RECORDS OF EL PASO COUNTY, TEXAS
- POC POINT OF COMMENCEMENT
- POB POINT OF BEGINNING
- BK. BOOK
- PG. PAGE
- ROW RIGHT OF WAY
- DOC. DOCUMENT
- FND. FOUND

LINE TABLE		
LINE No.	DIRECTION	LENGTH
L15	N87° 52' 49"W	15.00'
L16	N02° 07' 11"E	25.00'
L17	S87° 52' 49"E	15.00'
L18	S02° 07' 11"W	25.00'

**SURVEYOR'S CERTIFICATION**

I, CHRISTIAN M. WEGMANN, A TEXAS REGISTERED PROFESSIONAL LAND SURVEYOR, HEREBY CERTIFY THAT THIS SURVEY WAS PERFORMED UNDER MY SUPERVISION, AND THAT IT IS BASED ON AN ACTUAL FIELD SURVEY PERFORMED ON THE GROUND.



CHRISTIAN M. WEGMANN  
 REGISTERED PROFESSIONAL LAND SURVEYOR  
 TEXAS REGISTRATION NO. 6794



REV F T-22

DT053032

PAGE 4 OF 4

<p><b>HUITT - ZOLLARS INC.</b>                  5822 Cromo Drive, Suite 210                  El Paso, TX 79912                  PH. 915-587-4339                  Tx. Firm No. 10025803                  www.huitt-zollars.com</p>	PROJECT: 25 BUTTERFIELD TRAIL	<p>0.009 ACRES (375 SQ. FT.)                  A PORTION OF LOT 1, BLOCK 11                  BUTTERFIELD TRAIL INDUSTRIAL PARK                  UNIT TWO                  CITY OF EL PASO,                  EL PASO COUNTY, TEXAS</p>
	JOB #: R315453 01	
	DATE: MAY, 2022	
	SCALE: N/A	
	DRAWN: JZ	
CHECKED: CMW		
PATH: G:\proj\R315453 01-EPEC-DT053032 25 Butterfield Trail Survey\CMA 30 2022		

## Exhibit B (Page 13 of 24)

## Easement 4

**EXHIBIT "A"**

DT053032

HZI PROJECT No. R315453.01  
 0.002 ACRE ELECTRIC EASEMENT  
 OUT OF LOT 1, BLOCK 11  
 BUTTERFIELD TRAIL  
 INDUSTRIAL PARK UNIT TWO  
 CITY OF EL PASO  
 EL PASO COUNTY, TEXAS

That certain 0.002 acre parcel of land, being 10 feet in width, 5 feet on each side of the herein described centerline, situated within Lot 1, Block 11, Butterfield Trail Industrial Park Unit Two, recorded in Volume 57, Page 43, Plat records of El Paso County, Texas, within the City of El Paso, El Paso County, Texas, said centerline being more particularly described as follows (record dimensions shown in parenthesis ( ) are recited herein to reference Subdivision Plat of said Butterfield Trail Industrial Park Unit Two):

**COMMENCING** at a brass disk in hand hole found for city monument at the centerline intersection of Butterfield Trail Boulevard and Butterfield Circle, both being a 90 foot wide right-of-way per said Butterfield Trail Industrial Park Unit Two, said Point of Commencement having modified Texas Coordinate System (central zone, U.S. survey feet, NAD83) ground coordinates of N=10,676,995.07, E=415,198.61;

**THENCE** N 02°05'52" E, leaving said centerline, a distance of 45.00 feet to the northerly right-of-way line of said Butterfield Trail Boulevard;

**THENCE** N 87°54'08" W, continuing with said northerly right-of-way line, a distance of 72.47 feet (record: N 87°54'08" W) to a 5/8 inch rebar with cap, not legible found for the southeast corner of Lot 1, Block 11, of said Butterfield Trail Industrial Park Unit Two;

**THENCE** N 02°05'52" E, with the east line of said Lot 1, a distance of 68.20 feet (record: N 02°05'52" E), from which a found 1 inch aluminum cap stamped 5152 at the northeast corner of said Lot 1 bears N 02°05'52" E, a distance of 331.01 feet (record: N 02°05'52" E);

**THENCE** N 87°54'08" W, leaving said easterly line, across said Lot 1, a distance of 269.67 feet to the **POINT OF BEGINNING**, having modified Texas Coordinate System (central zone, U.S. survey feet, NAD83) ground coordinates of N=10,677,120.71, E=414,860.85;

**THENCE** N 54°31'00" W, a distance of 10.32 feet to the **POINT OF TERMINATION**, from which a 1 inch aluminum cap stamped "5152" found for the northeast corner of said Lot 1 bears N 42°38'25" E, a distance of 428.12 feet, said Point of Termination having modified Texas Coordinate System (central zone, U.S. survey feet, NAD83) ground coordinates of N=10,677,126.70, E=414,852.45;

## Exhibit B (Page 14 of 24)

## Easement 4


## EXHIBIT "A"

DT053032

HZI PROJECT No. R315453.01  
 0.002 ACRE ELECTRIC EASEMENT  
 OUT OF LOT 1, BLOCK 11  
 BUTTERFIELD TRAIL  
 INDUSTRIAL PARK UNIT TWO  
 CITY OF EL PASO  
 EL PASO COUNTY, TEXAS

Notes:

1. Distances and coordinates shown on this survey are surface values (US Survey Feet) based on a scaling of the Texas Coordinate System, Central Zone, NAD 83, by a ground scale factor of 1.00023100, at N=0, E=0.
2. All bearings (except parenthetical record bearings) shown on this survey are state plane grid bearings, derived from GPS observations.
3. A plat of survey on two letter size sheets is attached hereto, and made a part of this description for all purposes, and must be recorded with this description.
4. Subject parcel is 10 foot wide based on the described centerline. Sidelines of this centerline description shall be extended or shortened to end perpendicular to the Point of Beginning and Point of Termination.
5. Total area of subject parcel: 0.002 acres or 103 square feet



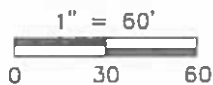
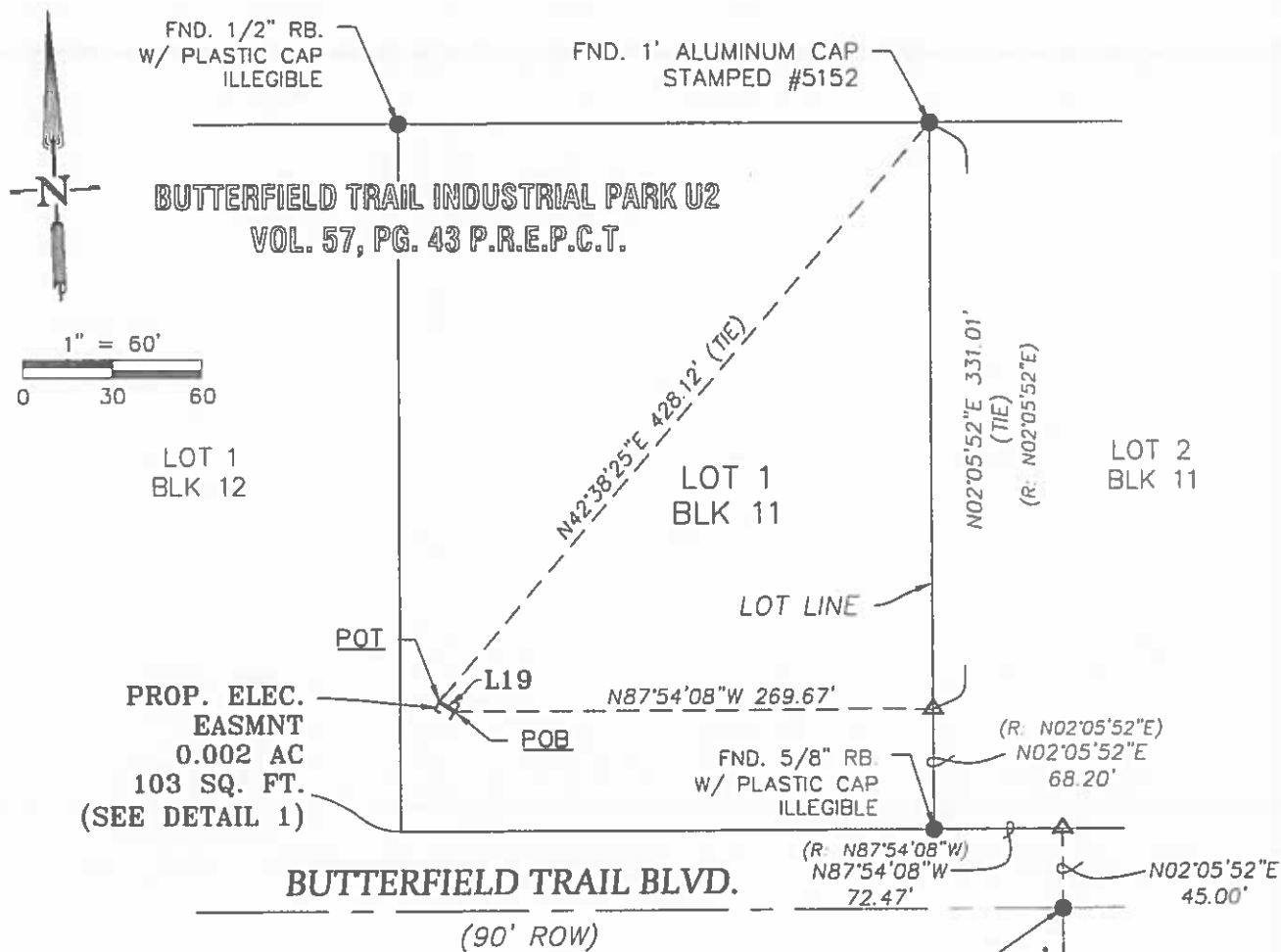
Christian M. Wegmann, Texas RPLS# 6794  
 Huitt-Zollars, Inc.  
 5822 Cromo Drive, Suite 210  
 El Paso, Texas 79912  
 Firm Registration No. 10025603  
 Phone 915-587-4339



Rev 7-1-22

Exhibit B (Page 15 of 24)

Easement 4



LOT 1  
BLK 12

PROP. ELEC.  
EASMNT  
0.002 AC  
103 SQ. FT.  
(SEE DETAIL 1)

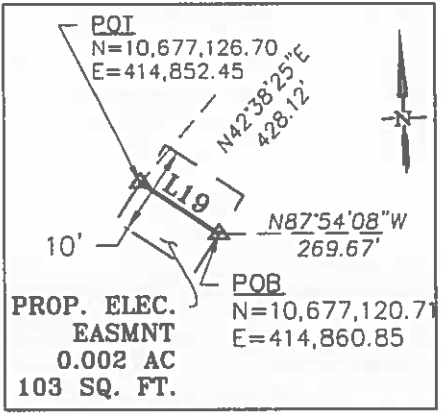
LOT 1  
BLK 11

LOT 2  
BLK 11

BUTTERFIELD TRAIL BLVD.  
(90' ROW)

BUTTERFIELD CIR.  
(90' ROW)

DETAIL 1 (1"=20')



POC  
FND. CITY MONUMENT  
N=10,676,995.07  
E=415,198.61

DT053032

PAGE 3 OF 4

<b>HUITT-ZOLLARS INC.</b> 5822 Cromo Drive, Suite 210 El Paso, TX 79912 PH. 915-587-4339 Tx. Firm No. 10025603 www.huitt-zollars.com	PROJECT: 25 BUTTERFIELD TRAIL JOB #: R315453.01	0.002 ACRES (103 SQ. FT.) A PORTION OF LOT 1, BLOCK 11 BUTTERFIELD TRAIL INDUSTRIAL PARK UNIT TWO CITY OF EL PASO, EL PASO COUNTY, TEXAS
	DATE: MAY, 2022	
	SCALE: 1"=100'	
	DRAWN: JZ	
	CHECKED: CMW	
PATH: G:\proj\W315453 01-EPEC-01053032 25 Butterfield Trail Survey\CAD 30 2022		

**Exhibit B (Page 16 of 24)  
Easement 4**

**SURVEY NOTES**

1. BASIS OF BEARING IS THE TEXAS COORDINATE SYSTEM OF 1983 (NAD83), CENTRAL ZONE (4203).
2. DISTANCES AND COORDINATES SHOWN HEREON ARE SURFACE VALUES, USING A GROUND SCALE FACTOR OF 1.000231, SCALED AT N=0, E=0.
3. BEARINGS AND DISTANCES SHOWN IN PARENTHESIS ( ) ARE LISTED TO RECITE RECORD DIMENSIONS PER THE FOLLOWING DOCUMENTS: BUTTERFIELD TRAIL INDUSTRIAL PARK UNIT TWO RECORDED IN VOL. 57, PG. 43, P.R.E.P.C.T.
4. THIS PLAT OF SURVEY SHALL ACCOMPANY THE ATTACHED METES AND BOUNDS DESCRIPTION FOR RECORDING PURPOSES.


**LEGEND**

- FND. SURVEY MARKER (AS NOTED)
- △ CALCULATED CORNER
- D.R.E.P.C.T. DEED RECORDS OF EL PASO COUNTY, TEXAS
- P.R.E.P.C.T. PLAT RECORDS OF EL PASO COUNTY, TEXAS
- POC POINT OF COMMENCEMENT
- POB POINT OF BEGINNING
- POT POINT OF TERMINATION
- BK. BOOK
- PG. PAGE
- ROW RIGHT OF WAY
- DOC. DOCUMENT
- FND. FOUND

LINE TABLE		
LINE No.	DIRECTION	LENGTH
L19	N54° 31' 00"W	10.32'

**SURVEYOR'S CERTIFICATION**

I, CHRISTIAN M. WEGMANN, A TEXAS REGISTERED PROFESSIONAL LAND SURVEYOR, HEREBY CERTIFY THAT THIS SURVEY WAS PERFORMED UNDER MY SUPERVISION, AND THAT IT IS BASED ON AN ACTUAL FIELD SURVEY PERFORMED ON THE GROUND.

  
 CHRISTIAN M. WEGMANN  
 REGISTERED PROFESSIONAL LAND SURVEYOR  
 TEXAS REGISTRATION NO. 6794



*Rev 7-7-22*

DT053032

PAGE 4 OF 4

<b>HUITT - ZOLLARS INC.</b> 5822 Cromo Drive, Suite 210 El Paso, TX 79912 PH. 915-587-4339 Tx. Firm No. 10025603 www.huilt-zollars.com	PROJECT: 25 BUTTERFIELD TRAIL	0.002 ACRES (103 SQ. FT.) A PORTION OF LOT 1, BLOCK 11 BUTTERFIELD TRAIL INDUSTRIAL PARK UNIT TWO CITY OF EL PASO, EL PASO COUNTY, TEXAS
	JOB #: R315453.01	
	DATE: MAY, 2022	
	SCALE: N/A	
	DRAWN: JZ	
CHECKED: CMW		
PATH: C:\proj\R315453.01-EPEC-DT053032 25 Butterfield Trail Survey\GVA_30_2022		



## Exhibit B (Page 17 of 24)

HZI PROJECT No. R315453.01  
 0.007 ACRE ELECTRIC EASEMENT  
 OUT OF LOT 1, BLOCK 11  
 BUTTERFIELD TRAIL  
 INDUSTRIAL PARK UNIT TWO  
 CITY OF EL PASO  
 EL PASO COUNTY, TEXAS

Easement 5

**EXHIBIT "A"**  
 DT053032

That certain parcel of land, being a portion of Lot 1, Block 11, Butterfield Trail Industrial Park Unit Two, as recorded in Volume 57, Page 43, Plat records of El Paso County, Texas, within the City of El Paso, El Paso County, Texas, and being more particularly described by Metes and Bounds as follows (record dimensions shown in parenthesis ( ) are recited herein to reference Subdivision Plat of said Butterfield Trail Industrial Park Unit Two):

**COMMENCING** at a brass disk in hand hole found for city monument at the centerline intersection of Butterfield Trail Boulevard and Butterfield Circle, both being a 90 foot wide right-of-way per said Butterfield Trail Industrial Park Unit Two, said Point of Commencement having modified Texas Coordinate System (central zone, U.S. survey feet, NAD83) ground coordinates of N=10,676,995.07, E=415,198.61;

**THENCE** N 02°05'52" E, leaving said centerline, a distance of 45.00 feet to the northerly right-of-way line of said Butterfield Trail Boulevard;

**THENCE** N 87°54'08" W, continuing with said northerly right-of-way line, a distance of 72.47 feet (record: N 87°54'08" W) to a 5/8 inch rebar with cap, not legible found for the southeast corner of Lot 1, Block 11, of said Butterfield Trail Industrial Park Unit Two;

**THENCE** N 02°05'52" E, with the east line of said Lot 1, a distance of 303.29 feet (record: N 02°05'52" E), from which a 1 inch aluminum cap stamped "5152" found at the northeast corner of said Lot 1 bears N 02°05'52" E, a distance of 95.92 feet (record: N 02°05'52" E);

**THENCE** N 87°54'08" W leaving said easterly lot line, across said Lot 1, a distance of 240.13 feet to the **POINT OF BEGINNING**, being the northeast corner of the herein described parcel, and having modified Texas Coordinate System (central zone, U.S. survey feet, NAD83) ground coordinates of N=10,677,354.57, E=414,898.97;

**THENCE** continuing over and across said Lot 1, the following four (4) courses and distances:

1. S 00°24'24" E, a distance of 16.00 feet to the southeast corner of the herein described parcel,
2. S 89°35'36" W, a distance of 20.00 feet to the southwest corner of the herein described parcel,
3. N 00°24'24" W, a distance of 16.00 feet to the northwest corner of the herein described parcel, and
4. N 89°35'36" E, a distance of 20.00 feet to the **POINT OF BEGINNING**, containing 0.007 acres or 320 square feet of land.

Exhibit B (Page 18 of 24)

Easement 5


EXHIBIT "A"

DT053032

HZI PROJECT No. R315453.01  
0.007 ACRE ELECTRIC EASEMENT  
OUT OF LOT 1, BLOCK 11  
BUTTERFIELD TRAIL  
INDUSTRIAL PARK UNIT TWO  
CITY OF EL PASO  
EL PASO COUNTY, TEXAS

Note:

Distances and coordinates shown on this survey are surface values (US Survey Feet) based on a scaling of the Texas Coordinate System, Central Zone, NAD 83, by a ground scale factor of 1.00023100, at N=0, E=0. All bearings (except parenthetical record bearings) shown on this survey are state plane grid bearings, derived from GPS observations. A plat of survey on two letter size sheets is attached hereto, and made a part of this description for all purposes, and must be recorded with this description.

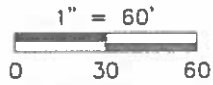
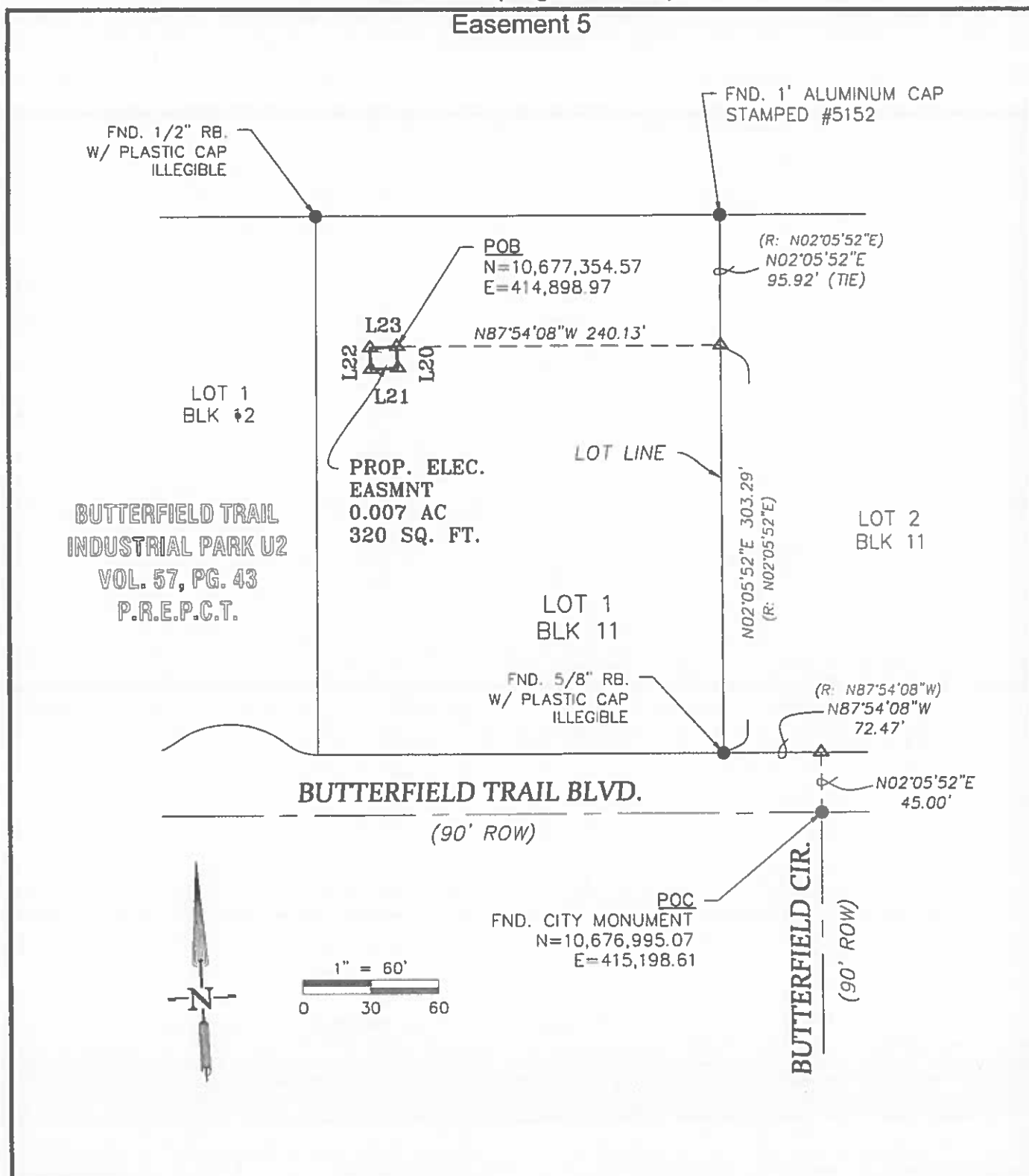


Christian M. Wegmann, Texas RPLS# 6794  
Huitt-Zollars, Inc.  
5822 Cromo Drive, Suite 210  
El Paso, Texas 79912  
Firm Registration No. 10025603  
Phone 915-587-4339



Exhibit B (Page 19 of 24)

Easement 5



POC  
FND. CITY MONUMENT  
N=10,676,995.07  
E=415,198.61

DT053032

PAGE 3 OF 4

<p><b>HUITT-ZOLLARS INC.</b> 5822 Cromo Drive, Suite 210 El Paso, TX 79912 PH. 915-587-4339 Tx. Firm No. 10025603 www.huitt-zollars.com</p>	<p>PROJECT: 25 BUTTERFIELD TRAIL</p>	<p>0.007 ACRES (320 SQ. FT.) A PORTION OF LOT 1, BLOCK 11 BUTTERFIELD TRAIL INDUSTRIAL PARK UNIT TWO CITY OF EL PASO, EL PASO COUNTY, TEXAS</p>
	<p>JOB #: R315453.01</p>	
	<p>DATE: MAY, 2022</p>	
	<p>SCALE: 1"=100'</p>	
	<p>DRAWN: JZ</p>	
<p>CHECKED: CMW</p>	<p>PATH: G:\proj\R315453.01-EPEC-01053032 25 Butterfield Trail Survey\CAD 3D 2022</p>	

Exhibit B (Page 20 of 24)

Easement 5

**SURVEY NOTES**

1. BASIS OF BEARING IS THE TEXAS COORDINATE SYSTEM OF 1983 (NAD83), CENTRAL ZONE (4203).
2. DISTANCES AND COORDINATES SHOWN HEREON ARE SURFACE VALUES, USING A GROUND SCALE FACTOR OF 1.000231, SCALED AT N=0, E=0.
3. BEARINGS AND DISTANCES SHOWN IN PARENTHESIS ( ) ARE LISTED TO RECITE RECORD DIMENSIONS PER THE FOLLOWING DOCUMENTS: BUTTERFIELD TRAIL INDUSTRIAL PARK UNIT TWO RECORDED IN VOL. 57, PG. 43, P.R.E.P.C.T.
4. THIS PLAT OF SURVEY SHALL ACCOMPANY THE ATTACHED METES AND BOUNDS DESCRIPTION FOR RECORDING PURPOSES.


LINE TABLE		
LINE No.	DIRECTION	LENGTH
L20	S00° 24' 24"E	16.00'
L21	S89° 35' 36"W	20.00'
L22	N00° 24' 24"W	16.00'
L23	N89° 35' 36"E	20.00'

**LEGEND**

- FND. SURVEY MARKER (AS NOTED)
- △ CALCULATED CORNER
- D.R.E.P.C.T. DEED RECORDS OF EL PASO COUNTY, TEXAS
- P.R.E.P.C.T. PLAT RECORDS OF EL PASO COUNTY, TEXAS
- POC POINT OF COMMENCEMENT
- POB POINT OF BEGINNING
- BK. BOOK
- PG. PAGE
- ROW RIGHT OF WAY
- DOC. DOCUMENT
- FND. FOUND

**SURVEYOR'S CERTIFICATION**

I, CHRISTIAN M. WEGMANN, A TEXAS REGISTERED PROFESSIONAL LAND SURVEYOR, HEREBY CERTIFY THAT THIS SURVEY WAS PERFORMED UNDER MY SUPERVISION, AND THAT IT IS BASED ON AN ACTUAL FIELD SURVEY PERFORMED ON THE GROUND.

  
 CHRISTIAN M. WEGMANN  
 REGISTERED PROFESSIONAL LAND SURVEYOR  
 TEXAS REGISTRATION NO. 6794



*Rev 7-22*

DT053032

PAGE 4 OF 4

<b>HUITT - ZOLLARS INC.</b> 5822 Cromo Drive, Suite 210 El Paso, TX 79912 PH. 915-587-4339 Tx. Firm No. 10025603 www.huilt-zollars.com	PROJECT: 25 BUTTERFIELD TRAIL JOB #: R315453.01	0.007 ACRES (320 SQ. FT.) A PORTION OF LOT 1, BLOCK 11 BUTTERFIELD TRAIL INDUSTRIAL PARK UNIT TWO CITY OF EL PASO, EL PASO COUNTY, TEXAS
	DATE: MAY, 2022	
	SCALE: N/A	
	DRAWN: JZ	
	CHECKED: CMW	
PATH: G:\proj\R315453\01-EPEC-DT053032 25 Butterfield Trail Survey\CVR 30 2972		

## Exhibit B (Page 21 of 24)

## Easement 6

**EXHIBIT "A"**

DT053032

HZI PROJECT No. R315453.01  
 0.041 ACRE ELECTRIC EASEMENT  
 OUT OF LOT 1, BLOCK 11  
 BUTTERFIELD TRAIL  
 INDUSTRIAL PARK UNIT TWO  
 CITY OF EL PASO  
 EL PASO COUNTY, TEXAS

That certain 0.041 acre parcel of land, being 10 feet in width, situated within Lot 1, Block 11, Butterfield Trail Industrial Park Unit Two, recorded in Volume 57, Page 43, plat records of El Paso County, Texas, within the City of El Paso, El Paso County, Texas, and being more particularly described by Metes and Bounds as follows (record dimensions shown in parenthesis ( ) are recited herein to reference Subdivision Plat of said Butterfield Trail Industrial Park Unit Two):

**COMMENCING** at a brass disk in hand hole found for city monument at the centerline intersection of Butterfield Trail Boulevard and Butterfield Circle, both being a 90 foot wide right-of-way per said Butterfield Trail Industrial Park Unit Two, said Point of Commencement having modified Texas Coordinate System (central zone, U.S. survey feet, NAD83) ground coordinates of N=10,676,995.07, E=415,198.61;

**THENCE** N 02°05'52" E, leaving said centerline, a distance of 45.00 feet to the northerly right-of-way line of said Butterfield Trail Boulevard;

**THENCE** N 87°54'08" W, with said northerly right-of-way line, a distance of 72.47 feet (record: N 87°54'08" W) to a 5/8 inch rebar with illegible plastic cap found for the southeast corner of said Lot 1, from which a 1 inch aluminum cap stamped "5152" found for the northeast corner of said Lot 1, bears N 02°05'52" E, a distance of 399.21 feet (record: N 02°05'52" E, 399.21 feet);

**THENCE** N 87°54'08" W, continuing with said northerly right-of-way line, being also the south line of said Lot 1, a distance of 292.20 feet (record: N 87°54'08" W) to the **POINT OF BEGINNING**, being the southeast corner of the herein described parcel, having modified Texas Coordinate System (central zone, U.S. survey feet, NAD83) ground coordinates of N=10,677,053.38, E=414,835.83;

**THENCE** N 87°54'08" W, continuing with said common line, a distance of 8.53 feet to the southwest corner of the herein described parcel, being also the southwest corner of said Lot 1;

**THENCE** N 02°12'07" E, leaving said common line, with the west line of said Lot 1, a distance of 5.81 feet to the northerly southwest corner of the herein described parcel, from which a 1/2 inch rebar with illegible plastic cap found for the northwest corner of said Lot 1, bears N 02°12'07" E, a distance of 393.40 feet (record: N 02°12'07" E);

**THENCE** leaving said west line, over and across said Lot 1, with the west, north and east lines of the herein described parcel, the following ten (10) courses and distances:

1. N 22°22'14" E, a distance of 37.41 feet,
2. N 12°55'11" E, a distance of 109.28 feet,
3. N 31°28'06" E, a distance of 6.14 feet,
4. N 02°13'18" E, a distance of 18.00 feet,
5. S 87°46'42" E, a distance of 12.00 feet,

## Exhibit B (Page 22 of 24)

## Easement 6

HZI PROJECT No. R315453.01  
 0.041 ACRE ELECTRIC EASEMENT  
 OUT OF LOT 1, BLOCK 11  
 BUTTERFIELD TRAIL  
 INDUSTRIAL PARK UNIT TWO  
 CITY OF EL PASO  
 EL PASO COUNTY, TEXAS

**EXHIBIT "A"**  
 DT053032

6. S 02°13'18" W, a distance of 18.00 feet,
7. N 87°46'42" W, a distance of 0.54 feet,
8. S 31°28'06" W, a distance of 10.11 feet,
9. S 12°55'11" W, a distance of 108.48 feet, and
10. S 22°22'14" W, a distance of 40.73 feet to the **POINT OF BEGINNING**, containing 0.041 acres or 1801 square feet of land.

Notes:

Distances and coordinates shown on this survey are surface values (US Survey Feet) based on a scaling of the Texas Coordinate System, Central Zone, NAD 83, by a ground scale factor of 1.00023100, at N=0, E=0. All bearings (except parenthetical record bearings) shown on this survey are state plane grid bearings, derived from GPS observations. A plat of survey on two letter size sheets is attached hereto, and made a part of this description for all purposes, and must be recorded with this description.


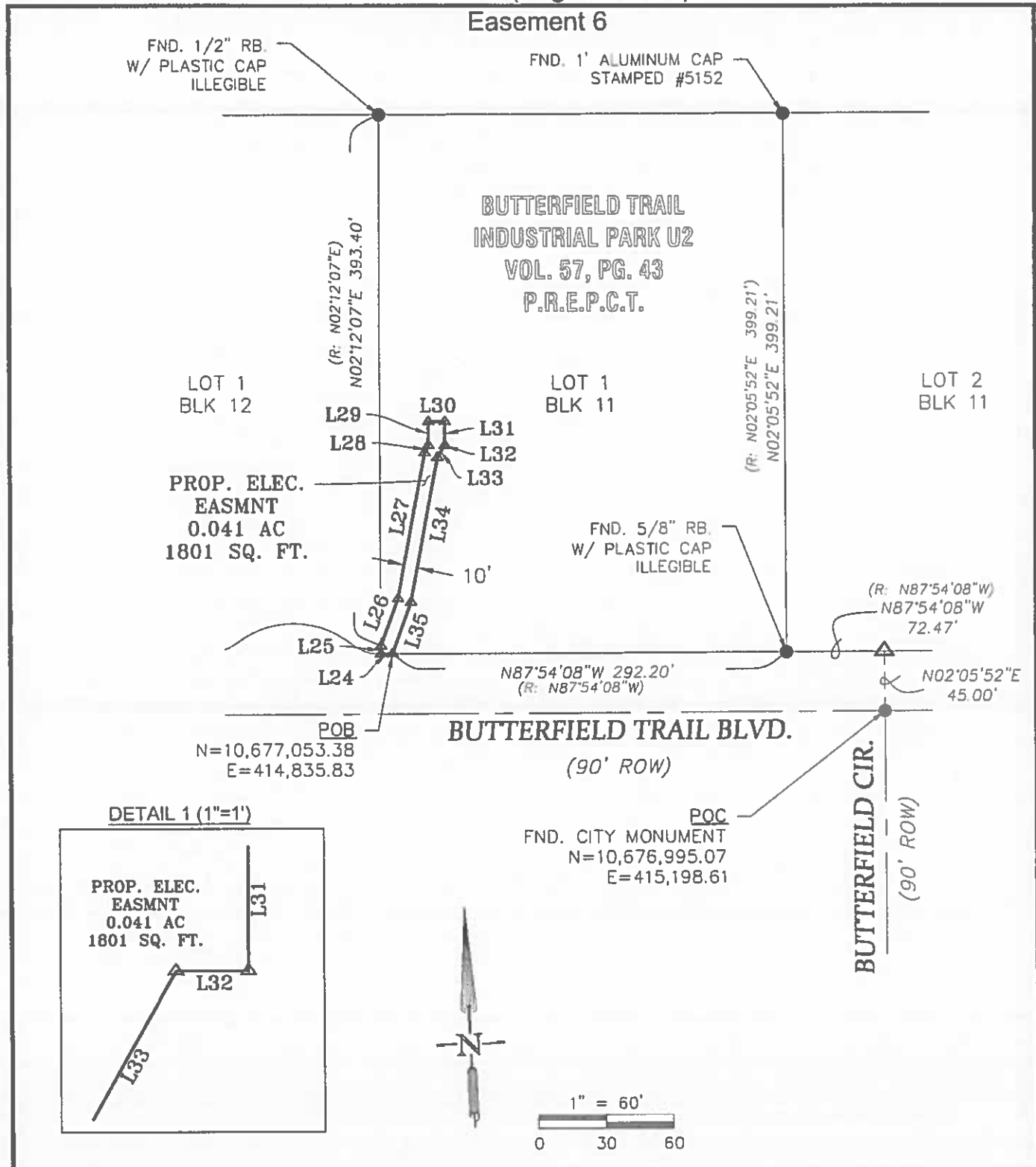
  
 Christian M. Wegmann, Texas RPLS# 6794  
 Huitt-Zollars, Inc.  
 5822 Cromo Drive, Suite 210  
 El Paso, Texas 79912  
 Firm Registration No. 10025603  
 Phone 915-587-4339

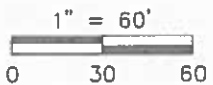
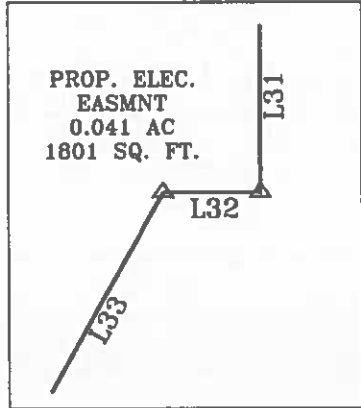


Exhibit B (Page 23 of 24)

Easement 6



DETAIL 1 (1"=1')



DT053032

PAGE 3 OF 4

<b>HUITT - ZOLLARS INC.</b> 5822 Cromo Drive, Suite 210 El Paso, TX 79912 PH. 915-587-4339 Tx. Firm No. 10025603 www.huilt-zollars.com	PROJECT: 25 BUTTERFIELD TRAIL JOB #: R315453.01	0.041 ACRES (1801 SQ. FT.) A PORTION OF LOT 1, BLOCK 11 BUTTERFIELD TRAIL INDUSTRIAL PARK UNIT TWO CITY OF EL PASO, EL PASO COUNTY, TEXAS
	DATE: JUNE, 2022	
	SCALE: 1"=100'	
	DRAWN: JZ	
	CHECKED: CMW	
	PATH: G:\proj\H315453.01-EPEC-DT053032 25 Butterfield Trail Survey\CAD 30 2022	

Exhibit B (Page 24 of 24)

Easement 6

SURVEY NOTES

1. BASIS OF BEARING IS THE TEXAS COORDINATE SYSTEM OF 1983 (NAD83), CENTRAL ZONE (4203).
2. DISTANCES AND COORDINATES SHOWN HEREON ARE SURFACE VALUES, USING A GROUND SCALE FACTOR OF 1.000231, SCALED AT N=0, E=0.
3. BEARINGS AND DISTANCES SHOWN IN PARENTHESIS ( ) ARE LISTED TO RECITE RECORD DIMENSIONS PER THE FOLLOWING DOCUMENTS: BUTTERFIELD TRAIL INDUSTRIAL PARK UNIT TWO RECORDED IN VOL. 57, PG. 43, P.R.E.P.C.T.
4. THIS PLAT OF SURVEY SHALL ACCOMPANY THE ATTACHED METES AND BOUNDS DESCRIPTION FOR RECORDING PURPOSES.


LINE TABLE		
LINE No.	DIRECTION	LENGTH
L24	N87° 54' 08"W	8.53'
L25	N02° 12' 07"E	5.81'
L26	N22° 22' 14"E	37.41'
L27	N12° 55' 11"E	109.28'
L28	N31° 28' 06"E	6.14'
L29	N02° 13' 18"E	18.00'
L30	S87° 46' 42"E	12.00'
L31	S02° 13' 18"W	18.00'
L32	N87° 46' 42"W	0.54'
L33	S31° 28' 06"W	10.11'
L34	S12° 55' 11"W	108.48'
L35	S22° 22' 14"W	40.73'

LEGEND

- FND. SURVEY MARKER (AS NOTED)
- △ CALCULATED CORNER
- D.R.E.P.C.T. DEED RECORDS OF EL PASO COUNTY, TEXAS
- P.R.E.P.C.T. PLAT RECORDS OF EL PASO COUNTY, TEXAS
- POC POINT OF COMMENCEMENT
- POB POINT OF BEGINNING
- BK. BOOK
- PG. PAGE
- ROW RIGHT OF WAY
- DOC. DOCUMENT
- FND. FOUND

SURVEYOR'S CERTIFICATION

I, CHRISTIAN M. WEGMANN, A TEXAS REGISTERED PROFESSIONAL LAND SURVEYOR, HEREBY CERTIFY THAT THIS SURVEY WAS PERFORMED UNDER MY SUPERVISION, AND THAT IT IS BASED ON AN ACTUAL FIELD SURVEY PERFORMED ON THE GROUND.

  
 CHRISTIAN M. WEGMANN  
 REGISTERED PROFESSIONAL LAND SURVEYOR  
 TEXAS REGISTRATION NO. 6794



REV 7-7-22

DT053032

PAGE 4 OF 4

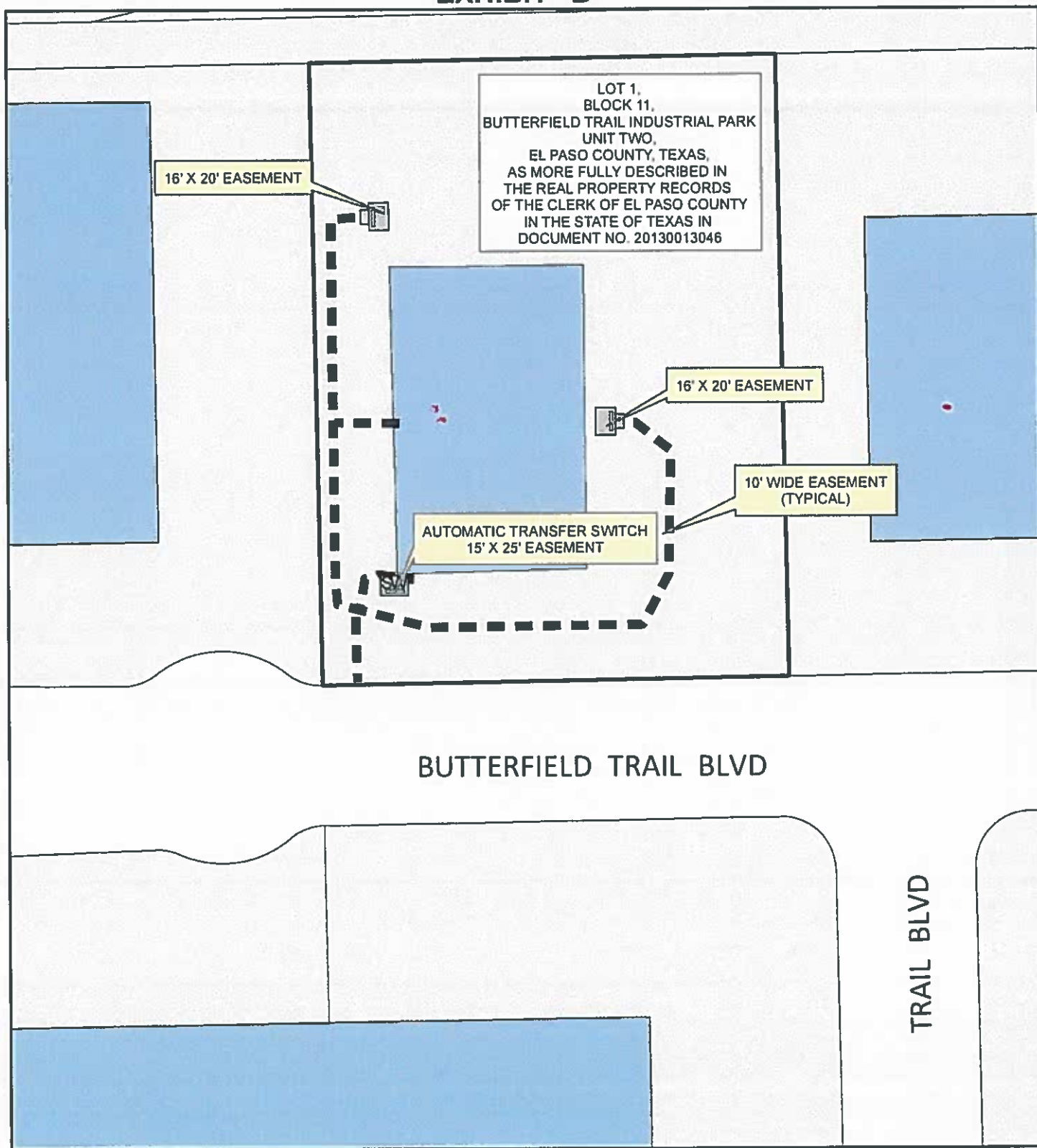
**HUITT-ZOLLARS INC.**  
 5822 Cromo Drive, Suite 210  
 El Paso, TX 79912  
 PH. 915-587-4339  
 Tx. Firm No. 10025803  
 www.huitt-zollars.com

PROJECT: 25 BUTTERFIELD TRAIL  
 JOB #: R315453.01  
 DATE: JUNE, 2022  
 SCALE: N/A  
 DRAWN: JZ  
 CHECKED: CMW  
 PATH: G:\proj\1315453.01-EPEC-DT053032 25 Butterfield Trail Survey\CWL 30 2022

0.041 ACRES (1801 SQ. FT.)  
 A PORTION OF LOT 1, BLOCK 11  
 BUTTERFIELD TRAIL INDUSTRIAL PARK  
 UNIT TWO  
 CITY OF EL PASO,  
 EL PASO COUNTY, TEXAS



# EXHIBIT "B"



	ANCHOR EASEMENT		UNDERGROUND EASEMENT
	SWITCH GEAR		PADMOUNT TRANSFORMER



25 Butterfield Trail  
El Paso, Texas 79906

WORK ORDER(S):DT053032

DATE: 6/6/2022



Legislation Text

---

File #: 22-962, Version: 1

---

**CITY OF EL PASO, TEXAS  
LEGISTAR AGENDA ITEM SUMMARY FORM**

**DISTRICT, DEPARTMENT, CONTACT INFORMATION:**

*Please choose District and Department from drop down menu. Please post exactly as example below.  
No Title's, No emails. Please use ARIAL 10 Font.*

**District 3**

Capital Improvement Department, Yvette Hernandez, (915) 212-1860

**AGENDA LANGUAGE:**

*This is the language that will be posted to the agenda. Please use ARIAL 11 Font.*

That the City Manager be authorized to sign a Second Amendment to an On-Call agreement for Professional Services with EMC Engineers, Inc., a Texas corporation, to provide for additional services at a cost not to exceed Forty-Eight Thousand Five Hundred Fifty-Five Dollars (\$48,555.00), thereby increasing the contract amount from Three Hundred Fifty Thousand Dollars (\$350,000.00) to Three Hundred Ninety- Eight Thousand Five Hundred Fifty-Five Dollars (\$398,555.00); and that the City Manager be authorized to establish the funding sources and make any necessary budget transfers and execute any and all documents necessary for the execution of the Second Amendment.

**CITY OF EL PASO, TEXAS  
AGENDA ITEM  
DEPARTMENT HEAD'S SUMMARY FORM**

**AGENDA DATE:** August 2, 2022

**PUBLIC HEARING DATE:** Not Applicable

**CONTACT PERSON(S) NAME AND PHONE NUMBER:** Yvette Hernandez, City Engineer  
(915) 212-1860

**DISTRICT(S) AFFECTED:** 3

**STRATEGIC GOAL:** No. 7: Enhance and Sustain El Paso's Infrastructure Network

**SUBGOAL:** 7.2. Improve competitiveness through infrastructure improvements impacting the quality of life.

**SUBJECT:**

That the City Manager be authorized to sign a Second Amendment to an On-Call agreement for Professional Services with EMC Engineers, Inc., a Texas corporation, to provide for additional services at a cost not to exceed Forty-Eight Thousand Five Hundred Fifty Five Dollars (\$48,555.00), thereby increasing the contract amount from Three Hundred Fifty Thousand Dollars (\$350,000.00) to Three Hundred Ninety- Eight Thousand Five Hundred Fifty Five Dollars (\$398,555.00); and that the City Manager be authorized to establish the funding sources and make any necessary budget transfers and execute any and all documents necessary for execution of the Second Amendment.

**BACKGROUND / DISCUSSION:**

On July 25, 2017 the City entered into an On-Call agreement for Professional Services agreement with EMC Engineers, Inc. (EMC) to perform mechanical and electrical professional engineering services. Under this agreement EMC was tasked with providing design and construction administration services for the Viscount Arterial Lighting and Landscaping project as well as providing similar services on a number of other projects. Additional funding is required to complete the Viscount Arterial Lighting project, however there is no funding capacity remaining in the contract. This action amends the contract and adds the necessary funding needed to complete the project.

**SELECTION SUMMARY:** N/A

**CONTRACT VARIANCE:** N/A

**PROTEST:** N/A

**PRIOR COUNCIL ACTION:** June 25, 2017 Council approved the award of the on-call contract.  
May 19, 2019 Council approved First Amendment to contract

**AMOUNT AND SOURCE OF FUNDING:** 2019 Capital Plan \$48,555.00

**HAVE ALL AFFECTED DEPARTMENTS BEEN NOTIFIED?**  YES  NO

**PRIMARY DEPARTMENT:** Capital Improvement

**SECONDARY DEPARTMENT:** Streets and Maintenance

\*\*\*\*\***REQUIRED AUTHORIZATION**\*\*\*\*\*

**DEPARTMENT HEAD:**

Assistant Director Capital Improvement



---

Yvette Hernandez, P.E. City Engineer

**RESOLUTION**

**BE IT RESOLVED BY THE CITY COUNCIL OF THE CITY OF EL PASO:**

**THAT** the City Manager be authorized to sign a Second Amendment to an On-Call Agreement for Professional Services with EMC Engineers, to provide for additional services at a cost not to exceed Forty-Eight Thousand Five Hundred Fifty Five Dollars (\$48,555.00), thereby increasing the contract amount from Three Hundred Fifty Thousand Dollars (\$350,000.00) to Three Hundred Ninety Eight Thousand Five Hundred Fifty Five Dollars (\$398,555.00); and that the City Manager be authorized to establish the funding sources and make any necessary budget transfers and execute any and all documents necessary for execution of the Second Amendment.

APPROVED THIS \_\_\_\_ DAY OF \_\_\_\_\_ 2022

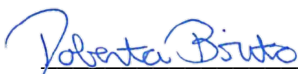
**CITY OF EL PASO:**

\_\_\_\_\_  
Oscar Leeser, Mayor


**ATTEST:**

\_\_\_\_\_  
Laura Prine  
City Clerk

**APPROVED AS TO FORM:**

  
\_\_\_\_\_  
Roberta Brito  
Assistant City Attorney

**APPROVED AS TO CONTENT:**

Assistant Director Capital Improvement  
  
\_\_\_\_\_  
Yvette Hernandez, P.E., City Engineer  
Capital Improvement Department

THE STATE OF TEXAS )  
 )  
COUNTY OF EL PASO )

SECOND AMENDMENT  
AGREEMENT  
FOR PROFESSIONAL SERVICES

This Second Amendment to that certain Agreement for Professional Services is made this \_\_\_\_ day of \_\_\_\_\_, 2022, by and between the City of El Paso, hereinafter referred to as the “*Owner*”, and **EMC ENGINEERS**, hereinafter referred to as the “*Consultant*.”

**WHEREAS** on July 25, 2017 the Owner and the Consultant entered into an On-Call Agreement for Professional Services (the “*Agreement*”) to perform mechanical and electrical professional engineering services.

**WHEREAS**, by Resolution approved by City Council on July 25, 2017, the City Manager, is authorized to establish the funding sources and make any necessary budget transfers and execute any and all documents necessary for the Agreement.

**WHEREAS**, the not-to-exceed value of the Agreement was TWO HUNDRED FIFTY THOUSAND DOLLARS (\$250,000.00).

**WHEREAS**, the Agreement included a provision that the City Engineer, without further authorization from City Council and in a form approved by the City Attorney, can increase the total payment identified for all basic services and reimbursables performed pursuant to the Agreement in an amount not to exceed FIFTY THOUSAND DOLLARS (\$50,000.00), and increase the total payment for Additional Services in an amount not to exceed FIFTY THOUSAND DOLLARS (\$50,000.00), if such services are necessary for proper execution of any identified Projects and the increased amounts are within the appropriate budget identified for the identified Projects.

**WHEREAS**, through a First Amendment to the Agreement dated May 9, 2019, the City Engineer authorized an increase in payment for basic services in an amount not to exceed FIFTY THOUSAND DOLLARS (\$50,000.00), and an increase in payment for Additional Services in an amount not to exceed FIFTY THOUSAND DOLLARS (\$50,000.00), thereby increasing the total contract amount from TWO HUNDRED FIFTY THOUSAND DOLLARS (\$250,000.00) to an amount not to exceed THREE HUNDRED FIFTY THOUSAND DOLLARS (\$350,000.00).

**WHEREAS**, Task Orders have been issued and completed under the Agreement totaling THREE HUNDRED FIFTY THOUSAND DOLLARS (\$350,000.00) thereby all authorized funding has been expended.

**WHEREAS**, an on-going Task Order under the Agreement for the capital project, the Viscount Arterial Lighting and Landscaping Project, requires additional funding in the amount of FORTY-EIGHT THOUSAND FIVE HUNDRED FIFTY FIVE DOLLARS (\$48,555.00) to complete the Project;

**WHEREAS**, the parties desire to amend the Agreement through this Second Amendment to provide additional funding to complete the Project thereby increasing the contract amount from

THREE HUNDRED FIFTY THOUSAND DOLLARS (\$350,000.00) to THREE HUNDRED NINETY-EIGHT THOUSAND FIVE HUNDRED FIFTY FIVE DOLLARS (\$398,555.00), thus providing an additional FORTY-EIGHT THOUSAND FIVE HUNDRED FIFTY FIVE DOLLARS (\$48,555.00) for necessary services to complete the Project.

**NOW, THEREFORE**, in consideration of the mutual promises set forth in this Second Amendment and for other good and valuable consideration, the receipt and sufficiency of which is hereby acknowledged, the parties agree as follows:

1. **Scope of Services.** The Owner hereby authorizes the Consultant to continue to perform the Services as described in Attachment “A” of the Agreement as well as perform the additional services as further described in Attachment “A” of this Second Amendment to the Agreement.
2. **Payments to Consultant.** Payment to the Consultant for the additional services that are the subject of this Second Amendment shall not exceed FORTY-EIGHT THOUSAND FIVE HUNDRED FIFTY FIVE DOLLARS (\$48,555.00).
3. **Time of Completion.** The additional services that are the subject of this Second Amendment shall be completed within the original project schedule as set forth in the Agreement, following the Owner’s written Notice to Proceed to the Consultant.
4. **Authority to Sign.** The parties represent and warrant that those persons signing this Second Amendment are authorized to execute this Second Amendment.
5. **Terms and Conditions.** All terms and conditions of the Agreement, and the First Amendment thereto, except as herein revised, shall remain in full force and effect.

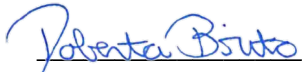
*(Signatures begin on following page.)*

**WITNESS THE FOLLOWING SIGNATURES AND SEALS:**


**THE CITY OF EL PASO**

\_\_\_\_\_  
Tomás González  
City Manager

**APPROVED AS TO FORM:**

  
\_\_\_\_\_  
Roberta Brito  
Assistant City Attorney

**APPROVED AS TO CONTENT:**

Assistant Director Capital Improvement  
  
\_\_\_\_\_  
Yvette Hernandez, P.E. City Engineer  
Capital Improvement Department

**ACKNOWLEDGEMENT**

**THE STATE OF TEXAS** §  
§  
**COUNTY OF EL PASO** §

This instrument was acknowledged before me on this \_\_\_\_\_ day of \_\_\_\_\_, 2022, by **Tomás González**, as **City Manager** of the **City of El Paso, Texas**.

\_\_\_\_\_  
**Notary Public, State of Texas**

**My commission expires:**

\_\_\_\_\_

*(Signatures continue on following page.)*





## ATTACHMENT A SCOPE OF SERVICES

- Redesign of completed work at request of user group
- Additional bidding phase services
- Construction Administration for increased scope



Legislation Text

---

File #: 22-965, Version: 1

---

**CITY OF EL PASO, TEXAS  
LEGISTAR AGENDA ITEM SUMMARY FORM**

**DISTRICT, DEPARTMENT, CONTACT INFORMATION:**

*Please choose District and Department from drop down menu. Please post exactly as example below.  
No Title's, No emails. Please use ARIAL 10 Font.*

**District 8**

Capital Improvement Department, Yvette Hernandez, (915) 212-1860

**AGENDA LANGUAGE:**

*This is the language that will be posted to the agenda. Please use ARIAL 11 Font.*

That the City Manager, or designee, be authorized to sign an Advance Funding Agreement by and between the City of El Paso and the State of Texas, acting by and through the Texas Department of Transportation, for Paso del Norte (PDN) Trail Magoffin Shared Use Path project, which has an estimated total project cost of \$1,308,751.00 of which the estimated local government participation amount is estimated at \$253,264.00. Further, that the City Manager, or designee, is authorized to sign all documents, agreement amendments, and perform all actions required to carry out the obligations of the City under this agreement.

**CITY OF EL PASO, TEXAS  
AGENDA ITEM  
DEPARTMENT HEAD'S SUMMARY FORM**

**AGENDA DATE:** August 2, 2022  
**PUBLIC HEARING DATE:** N/A  
**CONTACT PERSON(S) NAME AND PHONE NUMBER:** Yvette Hernandez, (915) 212-1860  
**DISTRICT(S) AFFECTED:** District 8  
**STRATEGIC GOAL:** No.7: Enhance and Sustain El Paso's Infrastructure Network  
**SUBGOAL:** N/A

**SUBJECT:**

That the City Manager, or designee, be authorized to sign an Advance Funding Agreement by and between the City of El Paso and the State of Texas, acting by and through the Texas Department of Transportation, for PDN Trail Magoffin Shared Use Path project, which has an estimated total project cost of \$1,308,751.00 of which the estimated local government participation amount is estimated at \$253,264.00. Further, that the City Manager, or designee, is authorized to sign all documents, agreement amendments, and perform all actions required to carry out the obligations of the City under this agreement.

**BACKGROUND / DISCUSSION:**

The scope of work for Project consists of preliminary engineering (schematic and environmental), plans specifications and estimates (PS&E), and construction of a shared use path with signage, ADA curb ramps and safe crossings at intersections. Project will run parallel to Magoffin Avenue. It will be a shared use path beginning at San Antonio Avenue and ending at Cotton Street. Magoffin is a three (3) lane street that will be reduced to two lanes and elimination of one lane will be used to construct the shared use path.

**PRIOR COUNCIL ACTION:**

**AMOUNT AND SOURCE OF FUNDING:**

FHWA/TxDOT and CO's

**HAVE ALL AFFECTED DEPARTMENTS BEEN NOTIFIED? \_\_\_ YES \_\_\_ NO**

**PRIMARY DEPARTMENT: Capital Improvement Department**

**SECONDARY DEPARTMENT:**

---

\*\*\*\*\*REQUIRED AUTHORIZATION\*\*\*\*\*

**DEPARTMENT HEAD:**

*Yvette Hernandez*

(If Department Head Summary Form is initiated by Purchasing, client department should sign also)

**RESOLUTION**

**NOW, THEREFORE, BE IT RESOLVED BY THE CITY COUNCIL OF THE CITY OF EL PASO:**

**THAT** the City Manager, or designee, be authorized to sign an Advance Funding Agreement by and between the City of El Paso and the State of Texas, acting by and through the Texas Department of Transportation, for PDN Trail Magoffin Shared Use Path project, which has an estimated total project cost of \$1,308,751.00 of which the estimated local government participation amount is estimated at \$253,264.00. Further, that the City Manager, or designee, is authorized to sign all documents, agreement amendments, and perform all actions required to carry out the obligations of the City under this agreement.

**APPROVED this \_\_\_\_\_ day of \_\_\_\_\_, 2022.**

**THE CITY OF EL PASO:**


**ATTEST:**

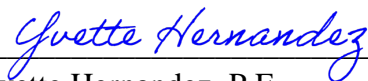
\_\_\_\_\_  
Oscar Leoser  
Mayor

\_\_\_\_\_  
Laura D. Prine  
City Clerk

**APPROVED AS TO FORM:**

**APPROVED AS TO CONTENT:**

  
\_\_\_\_\_  
Roberta Brito  
Assistant City Attorney

  
\_\_\_\_\_  
Yvette Hernandez, P.E.  
City Engineer

<b>TxDOT:</b>				<b>Federal Highway Administration:</b>	
CSJ #	0924-06-640			CFDA No.	20.205
District #	24-ELP	AFA ID	Z00003118	CFDA Title	Highway Planning and Construction
Code Chart 64 #	13400				
Project Name	PDN Trail Magoffin Shared Use Path				<i>AFA Not Used For Research &amp; Development</i>

**STATE OF TEXAS           §**

**COUNTY OF TRAVIS       §**

**ADVANCE FUNDING AGREEMENT  
FOR A TRANSPORTATION ALTERNATIVES  
SET-ASIDE (TASA) PROGRAM PROJECT  
MPO-Selected Off-System**

This Advance Funding Agreement for a Transportation Alternatives Set-Aside (TASA) Program Project (“Agreement”) is made between the State of Texas (State), acting through the Texas Department of Transportation, and the City of El Paso, acting through its duly authorized officials.

**WITNESSETH**

**WHEREAS**, federal law establishes federally funded programs for transportation improvements to implement its public purposes, and

**WHEREAS**, the Texas Transportation Code, Section 201.103 establishes that the State shall design, construct and operate a system of highways in cooperation with local governments, and Section 222.052 authorizes the Texas Transportation Commission to accept contributions from political subdivisions for development and construction of public roads and the state highway system within the political subdivision, and

**WHEREAS**, Federal law, 23 USC §134 and 49 USC §5303, requires that State and Metropolitan Planning Organizations (MPOs) develop transportation plans and programs for urbanized areas of Texas, and

**WHEREAS**, Federal and state laws require local governments to meet certain contract standards relating to the management and administration of State and federal funds, and

**WHEREAS**, the Texas Transportation Commission has codified 43 TAC, Rules 15.50-15.56 that describe federal, state, and local responsibilities for cost participation in highway improvement and other transportation projects, and

**WHEREAS**, the rules and procedures for the Transportation Alternatives Set-Aside Program (TASA) are established in 23 USC §133(h), and 43 Texas Administrative Code, Part 1, Chapter 11, Subchapter G, §§11.400 – 11.418, and

**WHEREAS**, the Local Government prepared and submitted to the State or Metropolitan Planning Organization (MPO) a project nomination package for TASA funding consideration, which is briefly described as a project which consist of a shared use path along Magoffin Avenue, and

<b>TxDOT:</b>				<b>Federal Highway Administration:</b>	
CSJ #	0924-06-640			CFDA No.	20.205
District #	24-ELP	AFA ID	Z00003118	CFDA Title	Highway Planning and Construction
Code Chart 64 #	13400				
Project Name	PDN Trail Magoffin Shared Use Path				<i>AFA Not Used For Research &amp; Development</i>

**WHEREAS**, the Texas Transportation Commission (Commission) passed Minute Order Number 116073 (MO) dated August 31, 2021 awarding funding for TASA projects in the TASA Program Call of the El Paso MPO, including Project, and

**WHEREAS**, the governing body of the Local Government has approved entering into this Agreement by resolution or ordinance dated {enter date of resolution}, which is attached to and made a part of this Agreement as Attachment C, Resolution or Ordinance. A map showing the Project location appears in Attachment A, Project Location Map, which is attached to and made a part of this Agreement, and

**NOW, THEREFORE**, the State and the Local Government agree as follows:

## AGREEMENT

### 1. Period of Agreement and Performance

- A. Period of Agreement. This Agreement becomes effective when signed by the last party whose signing makes the Agreement fully executed. This Agreement shall remain in effect until terminated as provided below.
- B. Period of Performance.
  - 1. The Performance Period for each phase of work begins on the date specified in the Federal Project Authorization and Agreement (FPAA) for that phase of work. Local Government may not begin work until issued the State Letter of Authority (SLOA) for that phase of work.
  - 2. The Performance Period for each phase of work ends on the date specified in the FPAA for that phase of work.

### 2. Scope of Work and Use of Project

- A. The scope of work for Project consists of preliminary engineering (schematic and environmental), plans specifications and estimates (PS&E), and construction of a shared use path with signage, ADA curb ramps and safe crossings at intersections. Project will run parallel to Magoffin Avenue. It will be a shared use path beginning at San Antonio Avenue and ending at Cotton Street. Magoffin is a three (3) lane street that will be reduced to two lanes and elimination of one lane will be used to construct the shared use path.
- B. Any project changes proposed must be submitted in writing by Local Government to State. Substantive changes may also require an amendment to this Agreement and the approval of the FHWA, State, MPO, or the Commission. Any changes undertaken without written approval and amendment of this Agreement may jeopardize not only the federal funding for the changes, but the federal funding of the entire Project.

### 3. Project Sources and Uses of Funds

The total estimated development cost of the Project is shown in Attachment B, Project Budget Estimate and Source of Funds (Attachment B).

- A. If Local Government will perform any work under this Agreement for which reimbursement will be provided by or through the State, the Local Government must complete training. If federal funds are being used, the training must be completed before federal spending authority is obligated. Training is complete when at least one

<b>TxDOT:</b>				<b>Federal Highway Administration:</b>	
<b>CSJ #</b>	0924-06-640			<b>CFDA No.</b>	20.205
<b>District #</b>	24-ELP	<b>AFA ID</b>	Z00003118	<b>CFDA Title</b>	Highway Planning and Construction
<b>Code Chart 64 #</b>	13400				
<b>Project Name</b>	PDN Trail Magoffin Shared Use Path				<i>AFA Not Used For Research &amp; Development</i>

individual who is working actively and directly on the Project successfully completes and receives a certificate for the course entitled “Local Government Project Procedures and Qualification for the Texas Department of Transportation” and retains qualification in accordance with applicable TxDOT procedures. Upon request, Local Government shall provide the certificate of qualification to State. The individual who receives the training certificate may be an employee of Local Government or an employee of a firm that has been contracted by Local Government to perform oversight of the Project. State in its discretion may deny reimbursement if Local Government has not continuously designated in writing a qualified individual to work actively on or to directly oversee the Project.

- B. The total estimated project cost as shown in Attachment B includes the Local Government’s estimated itemized cost of real property, utilities, environmental assessments, construction, and other construction related costs. To be eligible for reimbursement or as in-kind contribution, costs must have been included in the nomination form approved by the Texas Transportation Commission or MPO in consultation with State. Local Government must submit to State evidence of payment for eligible in-kind costs at least once per calendar quarter using the State’s In-Kind Match Reporting form.
- C. State and the Federal Government will not reimburse Local Government for any work performed outside the Performance Period. After federal funds have been obligated, State will send to Local Government a copy of the formal documentation showing the obligation of funds including federal award information. Local Government is responsible for 100 percent of the cost of any work performed under its direction or control before the federal spending authority is formally obligated.
- D. The Project budget and source of funds estimate based on the budget provided in the application is included in Attachment B. Attachment B shows the percentage and estimated dollar amounts to be contributed to Project by state and local sources, as well as the maximum amount in federal TASA funds assigned by the Commission or MPO in consultation with State. This Agreement may be amended from time to time as required to meet the funding commitments based on revisions to the TASA, FPAA, or other federal documents.
- E. State will be responsible for securing the federal share of funding required for the development and construction of Project, in an amount not to exceed 80 percent of the actual cost of the work up to the amount of funds approved for Project by the Texas Transportation Commission or MPO in consultation with State. Federal funds will be reimbursed on a cost basis. Project costs incurred prior to issuance of the SLOA are not eligible for reimbursement.
- F. The Local Government will be responsible for all non-federal or non-State participation costs associated with the Project, unless otherwise provided for in this Agreement or approved otherwise in an amendment to this Agreement. For items of work subject to specified percentage funding, the Local Government shall only in those instances be responsible for all Project costs that are greater than the maximum State and federal participation specified in Attachment B and for overruns in excess of the amount specified in Attachment B to be paid by the Local Government. If the Project was State-selected, the State may apply a portion of any excess program funds to cover all or a portion of any overrun based on criteria provided by 43 Tex. Admin. Code §11.411(d).



<b>TxDOT:</b>				<b>Federal Highway Administration:</b>	
<b>CSJ #</b>	0924-06-640			<b>CFDA No.</b>	20.205
<b>District #</b>	24-ELP	<b>AFA ID</b>	Z00003118	<b>CFDA Title</b>	Highway Planning and Construction
<b>Code Chart 64 #</b>	13400				
<b>Project Name</b>	PDN Trail Magoffin Shared Use Path				<i>AFA Not Used For Research &amp; Development</i>

- G. The budget in Attachment B will clearly state all items subject to fixed price funding, specified percentage funding, and the periodic payment schedule, when periodic payments have been approved by the State.
- H. When fixed price funding is used, the Local Government is responsible for the fixed price amount specified in Attachment B. Fixed prices are not subject to adjustment unless (1) differing site conditions are encountered; (2) further definition of the Local Government's requested scope of work identifies greatly differing costs from those estimated; (3) work requested by the Local Government is determined to be ineligible for federal participation; or (4) the adjustment is mutually agreed to by the State and the Local Government.
- I. Following execution of this Agreement, but prior to the performance of any plan review work by State, Local Government will pay to State the amount specified in Attachment B for plan review. At least 60 days prior to the date set for receipt of the construction bids, Local Government shall remit its remaining local match as specified in Attachment B for State's estimated construction oversight and construction cost.
- J. In the event State determines that additional funding is required by Local Government at any time during Project, State will notify Local Government in writing. Local Government is responsible for the percentage of the authorized Project cost shown in Attachment B and 100 percent of any overruns above the federally authorized amount. Local Government will make payment to State within 30 days from receipt of State's written notification.
- K. Whenever funds are paid by Local Government to State under this Agreement, Local Government will remit a warrant made payable to the "Texas Department of Transportation". The warrant will be deposited by State and managed by State. Funds may only be applied by State to Project.
- L. Upon completion of Project, State will perform a final accounting of Project costs. Any funds due to Local Government, State, or the Federal Government will be promptly paid by the owing party.
- M. In the event Project is not completed, State may seek reimbursement from Local Government of the expended federal funds. Local Government will remit the required funds to State within 60 days from receipt of State's notification.
- N. If any existing or future local ordinances, commissioners court orders, rules, policies, or other directives, including but not limited to outdoor advertising billboards and storm water drainage facility requirements, are more restrictive than state or federal regulations, or if any other locally proposed changes, including but not limited to plats or re-plats, result in increased costs, then any increased costs associated with the ordinances or changes will be paid by Local Government. The cost of providing right of way acquired by State shall mean the total expenses in acquiring the property interests through negotiations, including, but not limited to, expenses related to relocation, removal, and adjustment of eligible utilities.
- O. The state auditor may conduct an audit or investigation of any entity receiving funds from the State directly under the Agreement or indirectly through a contract or subcontract under the Agreement. Acceptance of funds directly under the Agreement or indirectly through a contract or subcontract under this Agreement acts as acceptance of the authority of the state auditor, under the direction of the legislative audit committee, to conduct an audit or investigation in connection with those funds. An entity that is the subject of an audit or investigation must provide the state auditor

<b>TxDOT:</b>				<b>Federal Highway Administration:</b>	
<b>CSJ #</b>	0924-06-640			<b>CFDA No.</b>	20.205
<b>District #</b>	24-ELP	<b>AFA ID</b>	Z00003118	<b>CFDA Title</b>	Highway Planning and Construction
<b>Code Chart 64 #</b>	13400				
<b>Project Name</b>	PDN Trail Magoffin Shared Use Path				<i>AFA Not Used For Research &amp; Development</i>

with access to any information the state auditor considers relevant to the investigation or audit.

- P. State will not pay interest on any funds provided by Local Government.
- Q. State will not execute the contract for the construction of Project until the required funding has been made available by Local Government in accordance with this Agreement.
- R. Local Government is authorized to submit requests for reimbursement by submitting the original of an itemized invoice in a form and containing all items required by State no more frequently than monthly, and no later than 90 days after costs are incurred. If Local Government submits invoices more than 90 days after the costs are incurred, and if federal funding is reduced as a result, State shall have no responsibility to reimburse Local Government for those costs.
- S. If Local government is an Economically Disadvantaged County (EDC) and if State has approved adjustments to the standard financing arrangement, this agreement reflects those adjustments.

**4. Termination of the Agreement**

- A. This Agreement may be terminated by any of the following conditions:
  - 1. By mutual written consent and agreement of all parties;
  - 2. By any party with 90 days written notice; or
  - 3. By either party, upon the failure of the other party to fulfill the obligations as set forth in this Agreement. Any cost incurred due to such breach of contract shall be paid by the breaching party.
- B. If the potential termination of this Agreement is due to the failure of Local Government to fulfill its contractual obligations, State will notify Local Government that possible breach of contract has occurred. Local Government should make every effort to remedy the breach within a period mutually agreed upon by both parties.
- C. The Agreement may be terminated by the State because the parties are not able to execute a mutually agreeable amendment when the costs for Local Government requested items increase significantly due to differing site conditions, determination that Local government requested work is ineligible for federal or state cost participation, or a more thorough definition of the Local Government’s proposed work scope identifies greatly differing costs from those estimated. The State will reimburse Local Government remaining funds to the Local Government within ninety (90) days of termination;
- D. If Local Government withdraws from Project after this Agreement is executed, Local Government shall be responsible for all direct and indirect Project costs as identified by the State’s cost accounting system and with 2 CFR Part 200 recapture requirements.
- E. A project may be eliminated from the program as outlined below. If Project is eliminated for any of these reasons, this Agreement will be appropriately terminated. A project may be eliminated from the program, and this Agreement terminated, if:
  - 1. Local Government fails to satisfy any requirements of the program rules cited in 43 Texas Administrative Code, Part 1, Chapter 11, Subchapter G, §§11.400 – 11.418.
  - 2. The implementation of Project would involve significant deviation from the activities proposed in the nomination form and approved by the Texas Transportation Commission or MPO in consultation with State.

<b>TxDOT:</b>				<b>Federal Highway Administration:</b>	
<b>CSJ #</b>	0924-06-640			<b>CFDA No.</b>	20.205
<b>District #</b>	24-ELP	<b>AFA ID</b>	Z00003118	<b>CFDA Title</b>	Highway Planning and Construction
<b>Code Chart 64 #</b>	13400				
<b>Project Name</b>	PDN Trail Magoffin Shared Use Path				<i>AFA Not Used For Research &amp; Development</i>

3. Local Government withdraws from participation in Project.
  4. State determines that federal funding may be lost due to Project not being implemented and completed.
  5. Funds are not appropriated, in which case this Agreement shall be terminated immediately with no liability to either party. Payment under this Agreement beyond the current fiscal biennium is subject to availability of appropriated funds.
  6. A construction contract has not been awarded or construction has not been initiated within three years after the date that the Commission or MPO selected the project or by a letting date determined by the state and agreed to by the Local Government.
  7. Local Government fails to attend progress meetings at least twice yearly, as scheduled by State.
- F. State, at its sole discretion, may terminate this Agreement if State does not receive project invoice from Local Government within 270 days of FPAA.

**5. Amendments**

This Agreement may be amended due to changes in the work, the amount of funding required to complete Project, or the responsibilities of the parties. Such amendment must be made through a mutually agreed upon, written amendment that is executed by the parties.

**6. Remedies**

This Agreement shall not be considered as specifying the exclusive remedy for any agreement default, but all remedies existing at law and in equity may be availed of by either party to this Agreement and shall be cumulative.

**7. Utilities**

Local Government shall be responsible for the adjustment, removal, or relocation of utilities or utility facilities in accordance with applicable State laws, regulations, rules, policies, and procedures, including any cost to State of a delay resulting from Local Government's failure to ensure that utilities or utility facilities are adjusted, removed, or relocated before the scheduled beginning of construction. At the State's discretion, State may reimburse Local Government for minor, incidental utility adjustments that are identified during the preliminary engineering phase if they are eligible for federal reimbursement. Local Government must obtain advance approval for any variance from established procedures. Before a construction contract is let, Local Government shall provide, at State's request, a certification stating that Local Government has completed the adjustment of all utilities that must be adjusted before construction begins. Additional utility work may be required due to unknown conditions discovered during construction. These costs may be eligible for TASA participation if the following conditions are met: (1) the activity is required to complete Project; (2) the cost is incidental to Project; and (3) TASA funding is available. Any change orders must be approved by State prior to incurring any cost for which reimbursement is sought.

**8. Environmental Assessment and Mitigation**

Development of Project must comply with the National Environmental Policy Act and the National Historic Preservation Act of 1966, which require environmental clearance of federal-aid projects.

<b>TxDOT:</b>				<b>Federal Highway Administration:</b>	
CSJ #	0924-06-640			CFDA No.	20.205
District #	24-ELP	AFA ID	Z00003118	CFDA Title	Highway Planning and Construction
Code Chart 64 #	13400				
Project Name	PDN Trail Magoffin Shared Use Path			<i>AFA Not Used For Research &amp; Development</i>	

- A. The **Local Government** is responsible for the identification and assessment of any environmental problems associated with the development of Project.
- B. Local Government is responsible for the cost of any environmental problem’s mitigation and remediation. These costs will not be reimbursed or credited towards Local Government’s financial share of Project unless specified in the nomination form and approved by State or MPO in consultation with State.
- C. Local Government is responsible for providing any public meetings or public hearings required for development of the environmental assessment, including any public hearing requirements that may be necessary when adding a bike lane.
- D. Before the advertisement for bids, Local Government shall provide to State written documentation from the appropriate regulatory agency or agencies that all environmental clearances have been obtained.

**9. Compliance with Accessibility Standards**

All parties to this Agreement shall ensure that the plans for and the construction of all projects subject to this Agreement are in compliance with standards issued or approved by the Texas Department of Licensing and Regulation (TDLR) as meeting or consistent with minimum accessibility requirements of the Americans with Disabilities Act (P.L. 101-336) (ADA).

**10. Architectural and Engineering Services**

- A. Architectural and engineering services for preliminary engineering will be provided by the **Local Government**. In procuring professional services, the parties to this Agreement must comply with federal requirements cited in 23 CFR Part 172 if Project is federally funded and Local Government will be seeking reimbursement for these services or if these services will be used as in-kind contributions; and with Texas Government Code Subchapter 2254.A., in all cases. Professional services contracts for federally funded projects must conform to federal requirements.
- B. The architectural contract documents shall be developed in accordance with the standards of the American Institute of Architects, the U.S. Secretary of the Interior’s Standards for Historic Preservation Projects, Standards and Guidelines for Archeology and Historic Preservation, the National Register Bulletin Number 36: Guidelines for Evaluating and Registering Historical Archeological Sites and in consultation with the State Historic Preservation Officer, as applicable. The engineering plans shall be developed in accordance with State’s applicable Standard Specifications for Construction and Maintenance of Highways, Streets and Bridges and the two American Association of State Highway and Transportation Officials’ (“AASHTO”) publications, “A Policy on Geometric Design of Highways and Streets” and “Guide for the Development of Bicycle Facilities,” as applicable. All design criteria for bicycle and pedestrian bridges must comply with TxDOT’s Bridge Design Manual and AASHTO’s Load and Resistance Factor Design (LRFD) Guide Specifications for the Design of Pedestrian Bridges (latest edition) as applicable. All contract procurement procedures and documents must adhere to the applicable requirements established in the Standard Specifications for Construction and Maintenance of Highways, Streets and Bridges. The use of other systems of specifications shall be approved by State in writing in advance.
- C. When architectural and engineering services are provided by or through Local Government, Local Government shall submit any plans it has completed to State for review and approval on an agreed upon schedule. Local Government may also submit

<b>TxDOT:</b>				<b>Federal Highway Administration:</b>	
CSJ #	0924-06-640			CFDA No.	20.205
District #	24-ELP	AFA ID	Z00003118	CFDA Title	Highway Planning and Construction
Code Chart 64 #	13400				
Project Name	PDN Trail Magoffin Shared Use Path				<i>AFA Not Used For Research &amp; Development</i>

the plans to State for review any time prior to completion. Local Government shall make the necessary revisions determined by State. Local Government will not let the construction contract until all required plans have received State approval.

- D. When architectural and engineering services are provided by or through State, then the State is responsible for the delivery and performance of any required architectural or preliminary engineering work. Local Government may review and comment on the work, including any proposed changes to the scope of work, as required to accomplish Project purposes. State will cooperate with Local Government in accomplishing these Project purposes to the degree permitted by state and federal law.

### 11. Construction Responsibilities

- A. The **Local Government** shall advertise for construction bids, issue bid proposals, receive and tabulate the bids, and award and administer the contract for construction of Project. Administration of the contract includes the responsibility for construction engineering and for issuance of any change orders, supplemental agreements, amendments, or additional work orders that may become necessary subsequent to the award of the construction contract. To ensure federal funding eligibility, projects must be authorized by State prior to advertising for construction.
- B. All contract letting and award procedures must be approved by State prior to letting and award of the construction contract, whether the construction contract is awarded by State or by Local Government.
- C. All contract change order review and approval procedures must be approved by State prior to start of construction.
- D. If the Local Government is the responsible party, the State must review and approve change orders.
- E. Upon completion of Project, the party constructing Project will issue and sign a "Notification of Completion" acknowledging Project's construction completion.
- F. For federally funded contracts, the parties to this Agreement will comply with federal construction requirements provided in 23 CFR Parts 633 and 635, and shall include the latest version of Form "FHWA-1273" in the contract bidding documents. If force account work will be performed, a finding of cost effectiveness shall be made in compliance with 23 CFR Subpart 635.B.
- G. Any field changes, supplemental agreements, or revisions to the design plans that may occur after the construction contract is awarded will be mutually agreed to by State and Local Government prior to authorizing the contractor to perform the work. Prior to completion of Project, the party responsible for construction will notify the other party to this Agreement of the anticipated completion date. All parties will be afforded the opportunity to assist in the final review of the construction services performed by the contractor.

### 12. Project Maintenance

- A. Upon completion of Project, Local Government will be responsible for maintaining the completed facility for public use. The property shall be maintained and operated for the purpose for which it was approved and funded for a period commensurate with the federal investment or State rules, whichever is greater. Should Local Government at any time after Project completion decide it can no longer maintain and operate Project

<b>TxDOT:</b>				<b>Federal Highway Administration:</b>	
<b>CSJ #</b>	0924-06-640			<b>CFDA No.</b>	20.205
<b>District #</b>	24-ELP	<b>AFA ID</b>	Z00003118	<b>CFDA Title</b>	Highway Planning and Construction
<b>Code Chart 64 #</b>	13400				
<b>Project Name</b>	PDN Trail Magoffin Shared Use Path				<i>AFA Not Used For Research &amp; Development</i>

for its intended purpose, Local Government shall consult with State and the FHWA as to the disposal or alternate uses, consistent with Project's original intent. State may require Local Government to return the federal funds in accordance with 2 CFR Part 200 federal recapture requirements. Should Local Government consider conveying the property, State and FHWA must be notified prior to the sale, transfer, or disposal of any property that received federal funds. Written concurrence of approval for the transaction, detailing any required recapture, must be obtained from FHWA prior to the transaction. Advance notice from Local Government of their intended action must be submitted to State for an FHWA review a minimum of 90 days prior to any action being taken by Local Government. Local Government shall be held responsible for reimbursement of all federal funds used or a portion of those funds based on a pro-rata amount, considering the original percentage of federal funds provided and the time elapsed from Project completion date. This same percentage of reimbursement also applies to any amount of profit that may be derived from the conveyance of the property, as applicable.

- B. Any manufacturer warranties extended to Local Government as a result of Project shall remain in the name of Local Government. State shall not be responsible for honoring any warranties under this Agreement.
- C. Should Local Government derive any income from the development and operation of Project, a portion of the proceeds sufficient for the maintenance and upkeep of the property shall be set aside for future maintenance. A project income report shall be submitted to State on a quarterly basis. Monies set aside according to this provision shall be expended using accounting procedures and with the property management standards established in 2 CFR Part 200.
- D. Should any historic properties be included in or affected by this federally funded Project, the historic integrity of the property and any contributing features must continue to be preserved regardless of any approved changes that may occur throughout the life of Project.

**13. Right of Way and Real Property Acquisition**

- A. Right of way and real property acquisition shall be the responsibility of Local Government. Title to right of way and other related real property must be acceptable to State before funds may be expended for the improvement of the right of way or real property.
- B. If Local Government is the owner of any part of Project site under this Agreement, Local Government shall permit State or its authorized representative access to occupy the site to perform all activities required to execute the work.
- C. Local Government will comply with and assume the costs for compliance with all the requirements of Title II and Title III of the Uniform Relocation Assistance and Real Property Acquisition Policies Act of 1970, 42 USC §4601 et seq., including those provisions relating to incidental expenses incurred by the property owners in conveying the real property to Local Government, and benefits applicable to the relocation of any displaced person as defined in 49 CFR §24.2(g). Documentation to support such compliance must be maintained and made available to State and its representatives for review and inspection.
- D. Local Government shall assume all costs and perform all work necessary to obtain needed evidence of title or right of use to the real property required for development of

<b>TxDOT:</b>				<b>Federal Highway Administration:</b>	
<b>CSJ #</b>	0924-06-640			<b>CFDA No.</b>	20.205
<b>District #</b>	24-ELP	<b>AFA ID</b>	Z00003118	<b>CFDA Title</b>	Highway Planning and Construction
<b>Code Chart 64 #</b>	13400				
<b>Project Name</b>	PDN Trail Magoffin Shared Use Path				<i>AFA Not Used For Research &amp; Development</i>

Project. Evidence of title or right of use shall be acquired in the name of (1) State, if the real property is to be made part of the State Highway System, or (2) Local Government, if the real property is not to be made part of the State Highway System. The evidence of title or rights shall be acceptable to State, and be free and clear of all encroachments. Local Government shall secure and provide easements and any needed rights of entry over any other land needed to develop Project according to the approved Project plans. Local Government shall be responsible for securing any additional real property required for completion of Project.

- E. Local Government shall prepare real property maps, property descriptions, and other data as needed to properly describe the real property and submit them to State for approval prior to Local Government acquiring the real property. Tracings of the maps shall be retained by Local Government for a permanent record.
- F. Local Government shall determine property values for each real property parcel to be purchased with federal funds using methods acceptable to State and shall submit to State a tabulation of the values so determined, signed by the appropriate Local Government representative. The tabulations must list the parcel numbers, ownership, acreage, and recommended compensation. The tabulation must be accompanied by an explanation to support the estimated values, together with a copy of the documentation and reports used in calculating each parcel's value. Expenses incurred by Local Government in performing this work may be eligible for reimbursement after Local Government has received written authorization by State to proceed with determination of real property values. State will review the data submitted and will base its reimbursement for parcel acquisitions on these in determining the fair market values. Local Government will not be reimbursed for right-of-way costs on state-selected projects.
- G. For State-selected TASA projects, Local Government shall not use eminent domain or condemnation to acquire real property for this TASA Project.
- H. Reimbursement for real property costs will be made to Local Government for real property purchased in an amount not to exceed 80 percent of the cost of the real property purchased in accordance with the terms and provisions of this Agreement. Reimbursement will be in an amount not to exceed 80 percent of State's predetermined fair market value of each parcel, or the net cost thereof, whichever is less. In addition, reimbursement will be made to Local Government for necessary payments to appraisers for expenses incurred in order to assure good title. Local Government will not be reimbursed for right-of-way costs on state-selected projects.
- I. Local Government and current property owner are responsible for any costs associated with the relocation of displaced persons and personal property as well as incidental expenses incurred in acquiring property to implement Project. State will not pay any of these costs.
- J. If Project requires the use of real property to which Local Government will not hold title, a separate agreement between the owners of the real property and Local Government must be executed prior to execution of this Agreement. The separate agreement between Local Government and the current property owner must establish that Project will be dedicated for public use for a period of time not less than ten years after project completion and commensurate with the federal investment. For State-selected projects, this is outlined in 43 Tex. Admin. Code §11.417. The separate agreement

<b>TxDOT:</b>				<b>Federal Highway Administration:</b>	
CSJ #	0924-06-640			CFDA No.	20.205
District #	24-ELP	AFA ID	Z00003118	CFDA Title	Highway Planning and Construction
Code Chart 64 #	13400				
Project Name	PDN Trail Magoffin Shared Use Path			<i>AFA Not Used For Research &amp; Development</i>	

must define the responsibilities of the parties as to the use of the real property and operation and maintenance of Project after completion. The separate agreement must be approved by State prior to its execution and a copy of the executed separate agreement shall be provided to State.

- K. Local Government shall execute individually or produce a legal document as necessary to provide for Project's continued use from the date of completion, and agrees to cause the same to be recorded in the land records of the appropriate jurisdiction.
- L. Local governments receiving federal funds must comply with 23 CFR Part 710 and 49 CFR Part 24, and with the procedures provided in Chapter 6 of the State's Local Government Project Policy Manual. Local Government agrees to monitor Project to ensure: (1) continued use of the property for approved activities, and (2) the repayment of the Federal funds, as appropriate. Local Government agrees to the review of their Project accounts and site visits by State during the development of Project at any time. Upon Project completion, State will continue to perform periodic visits to confirm Project's continued use and upkeep.
- M. Before the advertisement for bids, Local Government shall provide a certification to State that all real property has been acquired.

**14. Insurance**

- A. Should this Agreement authorize Local Government or its contractor to perform any work on State right of way, before beginning work, the entity performing the work shall provide State with a fully executed copy of State's Form 1560 Certificate of Insurance verifying the existence of coverage in the amounts and types specified on the Certificate of Insurance for all persons and entities working on State right of way. This coverage shall be maintained until all work on State right of way is complete. If coverage is not maintained, all work on State right of way shall cease immediately, and State may recover damages and all costs of completing the work.
- B. For projects including buildings, Local Government agrees to insure the building according to Department specifications and further agrees to name the Federal Government as a "Loss Payee" should the building be destroyed.

**15. Notices, Invoices, Payments, and Project Inquiries**

All notices to either party shall be delivered personally or sent by certified or U.S. mail, postage prepaid, addressed to that party at the following address:

<b>Local Government:</b>	<b>State:</b>
City of El Paso ATTN: CID Director of Grant Funded Program P.O. Box 1890 El Paso, Texas 79950-1890	Texas Department of Transportation ATTN: Director of Contract Services 125 E. 11 <sup>th</sup> Street Austin, TX 78701

All notices shall be deemed given on the date delivered in person or deposited in the mail, unless otherwise provided by this agreement. Either party may change the above address by sending written notice of the change to the other party. Either party may request in writing that notices shall be delivered personally or by certified U.S. mail, and that request shall be carried out by the other party.



<b>TxDOT:</b>				<b>Federal Highway Administration:</b>	
<b>CSJ #</b>	0924-06-640			<b>CFDA No.</b>	20.205
<b>District #</b>	24-ELP	<b>AFA ID</b>	Z00003118	<b>CFDA Title</b>	Highway Planning and Construction
<b>Code Chart 64 #</b>	13400				
<b>Project Name</b>	PDN Trail Magoffin Shared Use Path				<i>AFA Not Used For Research &amp; Development</i>

Invoicing, payment, and project inquiries must be sent to the following address, which the State may change by sending written notice of the change to the Local Government:

Texas Department of Transportation  
ATTN: Contract Office/ATP  
13301 Gateway Blvd., West  
El Paso, Texas 79928

All invoicing, payment, and project inquiries must include the following information:

County: El Paso  
Local Government: City of El Paso  
CSJ No.: 0924-06-640  
Project Name: Magoffin Shared Use Path  
Highway or Roadway: Magoffin Avenue to San Antonio Avenue

**16. Legal Construction**

In case one or more of the provisions contained in this Agreement shall for any reason be held invalid, illegal, or unenforceable in any respect, such invalidity, illegality, or unenforceability shall not affect any other provisions and this Agreement shall be construed as if it did not contain the invalid, illegal, or unenforceable provision.

**17. Responsibilities of the Parties**

Neither party is an agent, servant, or employee of the other party and each party is responsible for its individual acts and deeds as well as the acts and deeds of its contractors, employees, representatives, and agents.

**18. Ownership of Documents**

Upon completion or termination of this Agreement, all documents prepared by State shall remain the property of State. All data prepared under this Agreement shall be made available to State without restriction or limitation on their further use. All documents produced or approved or otherwise created by Local Government shall be transmitted to State in the form of photocopy reproduction on a monthly basis as required by State. The originals shall remain the property of Local Government.

**19. Document and Information Exchange**

Local Government agrees to electronically deliver to State all general notes, specifications, contract provision requirements, and related documentation in a Microsoft Word or similar format. If requested by State, Local Government will use State's document template. Local Government shall also provide a detailed construction time estimate, including types of activities and month in which the activity will be completed, in the format required by State. This requirement applies whether Local Government creates the documents with its own forces or by hiring a consultant or professional provider. At the request of State, Local Government shall submit any information required by State in the format directed by State.

<b>TxDOT:</b>				<b>Federal Highway Administration:</b>	
CSJ #	0924-06-640			CFDA No.	20.205
District #	24-ELP	AFA ID	Z00003118	CFDA Title	Highway Planning and Construction
Code Chart 64 #	13400				
Project Name	PDN Trail Magoffin Shared Use Path				<i>AFA Not Used For Research &amp; Development</i>

**20. Compliance with Laws**

The parties shall comply with all federal, state, and local laws, statutes, ordinances, rules and regulations, and the orders and decrees of any courts or administrative bodies or tribunals in any manner affecting the performance of this agreement. When required, Local Government shall furnish State with satisfactory proof of this compliance.

**21. Sole Agreement**

This Agreement constitutes the sole and only agreement between the parties and supersedes any prior understandings or written or oral agreements respecting the Agreement’s subject matter.

**22. Cost Principles**

In order to be reimbursed with federal funds, the parties shall comply with the Cost Principles established in 2 CFR Part 200 that specify that all reimbursed costs are allowable, reasonable, and allocable to Project.

**23. Procurement and Property Management Standards**

The parties to this Agreement shall adhere to the procurement and property management standards established in 2 CFR 200, Uniform Administrative Requirements, Cost Principles, and Audit Requirements for Federal Awards, and to the Texas Uniform Grant Management Standards. The State must pre-approve the Local Government’s procurement procedures for purchases to be eligible for state or federal funds.

**24. Inspection of Books and Records**

The parties to this Agreement shall maintain all books, documents, papers, accounting records, and other documentation relating to costs incurred under this Agreement and shall make such materials available to the State, the Local Government, and, if federally funded, the FHWA and the U.S. Office of the Inspector General or their duly authorized representatives for review and inspection at its office during the Agreement period and for seven (7) years from the date of final reimbursement by FHWA under this Agreement or until any impending litigation or claims are resolved. Additionally, the State, the Local Government, and the FHWA and their duly authorized representatives shall have access to all the governmental records that are directly applicable to this Agreement for the purpose of making audits, examinations, excerpts, and transcriptions.

**25. Civil Rights Compliance**

The parties to this Agreement are responsible for the following:

- A. Compliance with Regulations: Both parties will comply with the Acts and the Regulations relative to Nondiscrimination in Federally-assisted programs of the U.S. Department of Transportation (USDOT), the Federal Highway Administration (FHWA), as they may be amended from time to time, which are herein incorporated by reference and made part of this Agreement.
- B. Nondiscrimination: The Local Government, with regard to the work performed by it during the Agreement, will not discriminate on the grounds of race, color, or national origin in the selection and retention of subcontractors, including procurement of materials and leases of equipment. The Local Government will not participate directly or indirectly in the discrimination prohibited by the Acts and the Regulations, including

<b>TxDOT:</b>				<b>Federal Highway Administration:</b>	
<b>CSJ #</b>	0924-06-640			<b>CFDA No.</b>	20.205
<b>District #</b>	24-ELP	<b>AFA ID</b>	Z00003118	<b>CFDA Title</b>	Highway Planning and Construction
<b>Code Chart 64 #</b>	13400				
<b>Project Name</b>	PDN Trail Magoffin Shared Use Path				<i>AFA Not Used For Research &amp; Development</i>

employment practices when the Agreement covers any activity, project, or program set forth in Appendix B of 49 CFR Part 21.

- C. Solicitations for Subcontracts, Including Procurement of Materials and Equipment: In all solicitations either by competitive bidding or negotiation made by the Local Government for work to be performed under a subcontract, including procurement of materials or leases of equipment, each potential subcontractor or supplier will be notified by the Local Government of the Local Government's obligations under this Agreement and the Acts and Regulations relative to Nondiscrimination on the grounds of race, color, or national origin.
- D. Information and Reports: The Local Government will provide all information and reports required by the Acts, the Regulations, and directives issued pursuant thereto, and will permit access to its books, records, accounts, other sources of information, and facilities as may be determined by the State or the FHWA to be pertinent to ascertain compliance with such Acts, Regulations or directives. Where any information required of the Local Government is in the exclusive possession of another who fails or refuses to furnish this information, the Local Government will so certify to the State or the FHWA, as appropriate, and will set forth what efforts it has made to obtain the information.
- E. Sanctions for Noncompliance: In the event of the Local Government's noncompliance with the Nondiscrimination provisions of this Agreement, the State will impose such contract sanctions as it or the FHWA may determine to be appropriate, including, but not limited to:
  1. withholding of payments to the Local Government under the Agreement until the Local Government complies and/or
  2. cancelling, terminating, or suspending of the Agreement, in whole or in part.
- F. Incorporation of Provisions: The Local Government will include the provisions of paragraphs (A) through (F) in every subcontract, including procurement of materials and leases of equipment, unless exempt by the Acts, the Regulations and directives issued pursuant thereto. The Local Government will take such action with respect to any subcontract or procurement as the State or the FHWA may direct as a means of enforcing such provisions including sanctions for noncompliance. Provided, that if the Local Government becomes involved in, or is threatened with, litigation with a subcontractor or supplier because of such direction, the Local Government may request the State to enter into such litigation to protect the interests of the State. In addition, the Local Government may request the United States to enter into such litigation to protect the interests of the United States.

**26. Pertinent Non-Discrimination Authorities**

During the performance of this Agreement, each party, for itself, its assignees, and successors in interest agree to comply with the following nondiscrimination statutes and authorities; including but not limited to:

- A. Title VI of the Civil Rights Act of 1964 (42 U.S.C. § 2000d et seq., 78 stat. 252), (prohibits discrimination on the basis of race, color, national origin); and 49 CFR Part 21.
- B. The Uniform Relocation Assistance and Real Property Acquisition Policies Act of 1970, (42 U.S.C. § 4601), (prohibits unfair treatment of persons displaced or whose property has been acquired because of federal or federal-aid programs and projects).

<b>TxDOT:</b>				<b>Federal Highway Administration:</b>	
CSJ #	0924-06-640			CFDA No.	20.205
District #	24-ELP	AFA ID	Z00003118	CFDA Title	Highway Planning and Construction
Code Chart 64 #	13400				
Project Name	PDN Trail Magoffin Shared Use Path			<i>AFA Not Used For Research &amp; Development</i>	

- C. Federal-Aid Highway Act of 1973, (23 U.S.C. § 324 et seq.), as amended, (prohibits discrimination on the basis of sex).
- D. Section 504 of the Rehabilitation Act of 1973, (29 U.S.C. § 794 et seq.) as amended, (prohibits discrimination on the basis of disability); and 49 CFR Part 27.
- E. The Age Discrimination Act of 1975, as amended, (42 U.S.C. § 6101 et seq.), (prohibits discrimination on the basis of age).
- F. Airport and Airway Improvement Act of 1982, (49 U.S.C. Chapter 471, Section 47123), as amended, (prohibits discrimination based on race, creed, color, national origin, or sex).
- G. The Civil Rights Restoration Act of 1987, (PL 100-209), (Broadened the scope, coverage and applicability of Title VI of the Civil Rights Act of 1964, The Age Discrimination Act of 1975 and Section 504 of the Rehabilitation Act of 1973, by expanding the definition of the terms “programs or activities” to include all of the programs or activities of the federal-aid recipients, subrecipients and contractors, whether such programs or activities are federally funded or not).
- H. Titles II and III of the Americans with Disabilities Act, which prohibits discrimination on the basis of disability in the operation of public entities, public and private transportation systems, places of public accommodation, and certain testing entities (42 U.S.C. §§ 12131-12189) as implemented by Department of Transportation regulations at 49 C.F.R. Parts 37 and 38.
- I. The Federal Aviation Administration’s Nondiscrimination statute (49 U.S.C. § 47123) (prohibits discrimination on the basis of race, color, national origin, and sex).
- J. Executive Order 12898, Federal Actions to Address Environmental Justice in Minority Populations and Low-Income Populations, which ensures nondiscrimination against minority populations by discouraging programs, policies, and activities with disproportionately high and adverse human health or environmental effects on minority and low-income populations.
- K. Executive Order 13166, Improving Access to Services for Persons with Limited English Proficiency, and resulting agency guidance, national origin discrimination includes discrimination because of limited English proficiency (LEP). To ensure compliance with Title VI, the parties must take reasonable steps to ensure that LEP persons have meaningful access to the programs (70 Fed. Reg. at 74087 to 74100).
- L. Title IX of the Education Amendments of 1972, as amended, which prohibits the parties from discriminating because of sex in education programs or activities (20 U.S.C. 1681 et seq.).

**27. Disadvantaged Business Enterprise Program Requirements**

- A. The parties shall comply with the Disadvantaged Business Enterprise (“DBE”) Program requirements established in 49 CFR Part 26.
- B. Local Government shall adopt, in its totality, State’s federally approved DBE program.
- C. Local Government shall set an appropriate DBE goal consistent with State’s DBE guidelines and in consideration of Local market, project size, and nature of the goods or services to be acquired. Local Government shall have final decision-making authority regarding the DBE goal and shall be responsible for documenting its actions.
- D. Local Government shall follow all other parts of State’s DBE program referenced in TxDOT Form 2395, Memorandum of Understanding Regarding the Adoption of the Texas Department of Transportation’s Federally-Approved Disadvantaged Business

<b>TxDOT:</b>				<b>Federal Highway Administration:</b>	
<b>CSJ #</b>	0924-06-640			<b>CFDA No.</b>	20.205
<b>District #</b>	24-ELP	<b>AFA ID</b>	Z00003118	<b>CFDA Title</b>	Highway Planning and Construction
<b>Code Chart 64 #</b>	13400				
<b>Project Name</b>	PDN Trail Magoffin Shared Use Path				<i>AFA Not Used For Research &amp; Development</i>

Enterprise by Entity, and attachments found at web address:

[http://ftp.dot.state.tx.us/pub/txdot-info/bop/dbe/mou/mou\\_attachments.pdf](http://ftp.dot.state.tx.us/pub/txdot-info/bop/dbe/mou/mou_attachments.pdf).

- E. Local Government shall not discriminate on the basis of race, color, national origin, or sex in the award and performance of any DOT-assisted contract or in the administration of its DBE program or the requirements of 49 CFR Part 26. Local Government shall take all necessary and reasonable steps under 49 CFR Part 26 to ensure non-discrimination in award and administration of DOT-assisted contracts. State’s DBE program, as required by 49 CFR Part 26 and as approved by DOT, is incorporated by reference in this Agreement. Implementation of this program is a legal obligation and failure to carry out its terms shall be treated as a violation of this Agreement. Upon notification to Local Government of its failure to carry out its approved program, State may impose sanctions as provided for under 49 CFR Part 26 and may, in appropriate cases, refer the matter for enforcement under 18 USC 1001 and the Program Fraud Civil Remedies Act of 1986 (31 USC § 3801 et seq.).
- F. Each contract Local Government signs with a contractor (and each subcontract the prime contractor signs with a subcontractor) must include the following assurance: “The contractor, sub-recipient, or sub-contractor shall not discriminate on the basis of race, color, national origin, or sex in the performance of this contract. The contractor shall carry out applicable requirements of 49 CFR Part 26 in the award and administration of DOT-assisted contracts. Failure by the contractor to carry out these requirements is a material breach of this agreement, which may result in the termination of this agreement or such other remedy as the recipient deems appropriate.”

**28. Debarment Certifications**

The parties are prohibited from making any award at any tier to any party that is debarred or suspended or otherwise excluded from or ineligible for participation in Federal Assistance Programs under Executive Order 12549, “Debarment and Suspension.” By executing this Agreement, Local Government certifies that it and its principals are not currently debarred, suspended, or otherwise excluded from or ineligible for participation in Federal Assistance Programs under Executive Order 12549, and further certifies that it will not do business with any party, to include principals, that is currently debarred, suspended, or otherwise excluded from or ineligible for participation in Federal Assistance Programs under Executive Order 12549. The parties to this Agreement shall require any party to a contract, subcontract, or purchase order awarded under this Agreement to certify its eligibility to receive federal funds and, when requested by State, to furnish a copy of the certification.

If state funds are used, the parties are prohibited from making any award to any party that is debarred under the Texas Administrative Code, Title 34, Part 1, Chapter 20, Subchapter G, Rule §20.585 and the Texas Administrative Code, Title 43, Part 1, Chapter 9, Subchapter G.

**29. Lobbying Certification**

In executing this Agreement, each signatory certifies to the best of that signatory’s knowledge and belief, that:

- A. No federal appropriated funds have been paid or will be paid by or on behalf of the parties to any person for influencing or attempting to influence an officer or employee of any federal agency, a Member of Congress, an officer or employee of Congress, or an

<b>TxDOT:</b>				<b>Federal Highway Administration:</b>	
<b>CSJ #</b>	0924-06-640			<b>CFDA No.</b>	20.205
<b>District #</b>	24-ELP	<b>AFA ID</b>	Z00003118	<b>CFDA Title</b>	Highway Planning and Construction
<b>Code Chart 64 #</b>	13400				
<b>Project Name</b>	PDN Trail Magoffin Shared Use Path				<i>AFA Not Used For Research &amp; Development</i>

employee of a Member of Congress in connection with the awarding of any federal contract, the making of any federal grant, the making of any federal loan, the entering into of any cooperative agreement, and the extension, continuation, renewal, amendment, or modification of any federal contract, grant, loan, or cooperative agreement.

- B. If any funds other than federal appropriated funds have been paid or will be paid to any person for influencing or attempting to influence an officer or employee of any agency, a Member of Congress, an officer or employee of Congress, or an employee of a Member of Congress in connection with federal contracts, grants, loans, or cooperative agreements, the signatory for Local Government shall complete and submit the federal Standard Form-LLL, "Disclosure Form to Report Lobbying," in accordance with its instructions.
- C. The parties shall require that the language of this certification be included in the award documents for all sub-awards at all tiers (including subcontracts, sub-grants, and contracts under grants, loans, and cooperative agreements) and all sub-recipients shall certify and disclose accordingly. Submission of this certification is a prerequisite imposed by 31 USC §1352 for making or entering into this transaction. Any person who fails to file the required certification shall be subject to a civil penalty of not less than \$10,000 and not more than \$100,000 for each such failure.

**30. Federal Funding Accountability and Transparency Act Requirements**

- A. Any recipient of funds under this agreement agrees to comply with the Federal Funding Accountability and Transparency Act (FFATA) and implementing regulations at 2 CFR Part 170, including Appendix A. This agreement is subject to the following award terms: <http://www.gpo.gov/fdsys/pkg/FR-2010-09-14/pdf/2010-22705.pdf> and <http://www.gpo.gov/fdsys/pkg/FR-2010-09-14/pdf/2010-22706.pdf>.
- B. Local Government agrees that it shall:
  - 1. Obtain and provide to State a System for Award Management (SAM) number (Federal Acquisition Regulation (FAR) Subpart 4.11) if this award provides more than \$25,000 in Federal funding. The SAM number may be obtained by visiting the SAM website whose address is: <https://sam.gov/SAM/pages/public/index.jsf>
  - 2. Obtain and provide to State a Data Universal Numbering System (DUNS) number, a unique nine-character number that allows the federal government to track the distribution of federal money. The DUNS number may be requested free of charge for all businesses and entities required to do so by visiting the Dun & Bradstreet on-line registration website <http://fedgov.dnb.com/webform>; and
  - 3. Report the total compensation and names of its top five executives to State if:
    - a. More than 80 percent of annual gross revenues are from the Federal government, and those revenues are greater than \$25,000,000; and
    - b. The compensation information is not already available through reporting to the U.S. Securities and Exchange Commission.

**31. Single Audit Report**

- A. The parties shall comply with the requirements of the Single Audit Act of 1984, P.L. 98-502, ensuring that the single audit report includes the coverage stipulated in 2 CFR Part 200.

<b>TxDOT:</b>				<b>Federal Highway Administration:</b>	
CSJ #	0924-06-640			CFDA No.	20.205
District #	24-ELP	AFA ID	Z00003118	CFDA Title	Highway Planning and Construction
Code Chart 64 #	13400				
Project Name	PDN Trail Magoffin Shared Use Path			<i>AFA Not Used For Research &amp; Development</i>	

- B. If threshold expenditures of \$750,000 or more are met during the fiscal year, the Local Government must submit a Single Audit Report and Management Letter (if applicable) to TxDOT's Compliance Division, 125 East 11th Street, Austin, TX 78701 or contact TxDOT's Compliance Division at [singleaudits@txdot.gov](mailto:singleaudits@txdot.gov).
- C. If expenditures are less than the threshold during Local Government's fiscal year, Local Government must submit a statement to TxDOT's Compliance Division as follows: *We did not meet the \$\_\_\_\_\_ expenditure threshold and therefore, are not required to have a single audit performed for FY\_\_\_\_\_.*
- D. For each year Project remains open for federal funding expenditures, Local Government will be responsible for filing a report or statement as described above. The required annual filing shall extend throughout the life of the agreement, unless otherwise amended or Project has been formally closed out and no charges have been incurred within the current fiscal year.

**32. Signatory Warranty**


Each signatory warrants that the signatory has necessary authority to execute this agreement on behalf of the entity represented.

Each party is signing this agreement on the date stated under that party's signature.

**APPROVED AS TO CONTENT**

**THE LOCAL GOVERNMENT**

\_\_\_\_\_  
Signature  
Samuel Rodriguez for  
Tomas Gonzalez  
\_\_\_\_\_  
Typed or Printed Name  
  
City Manager  
\_\_\_\_\_  
Typed or Printed Title  
  
\_\_\_\_\_  
Date

\_\_\_\_\_  
  
Signature  
Yvette Hernandez  
\_\_\_\_\_  
Typed or Printed Name  
  
City Engineer  
\_\_\_\_\_  
Typed or Printed Title  
7/14/22  
\_\_\_\_\_  
Date

<b>TxDOT:</b>				<b>Federal Highway Administration:</b>	
CSJ #	0924-06-640			CFDA No.	20.205
District #	24-ELP	AFA ID	Z00003118	CFDA Title	Highway Planning and Construction
Code Chart 64 #	13400				
Project Name	PDN Trail Magoffin Shared Use Path				<i>AFA Not Used For Research &amp; Development</i>

**APPROVED AS TO FORM**

*Roberta Brito*

Signature

Roberta Brito

Typed or Printed Name

Assistant City Attorney

Typed or Printed Title

07/13/2022

Date

**THE STATE OF TEXAS**

Signature

Kenneth Stewart

Typed or Printed Name

Director of Contract Services

Typed or Printed Title

Date



<b>TxDOT:</b>				<b>Federal Highway Administration:</b>	
<b>CSJ #</b>	0924-06-640			<b>CFDA No.</b>	20.205
<b>District #</b>	24 -ELP	<b>AFA ID</b>		<b>CFDA Title</b>	Highway Planning and Construction
<b>Code Chart 64 #</b>	13400				
<b>Project Name</b>	PDN Trail Magoffin Shared Use Path			<i>AFA Not Used For Research &amp; Development</i>	

**ATTACHMENT A  
PROJECT LOCATION MAP**



<b>CSJ #</b>	<b>0924-06-640</b>	<b>Project Name:</b>	<b>Magoffin Shared Use Path</b>	<b>AFA ID:</b>	
--------------	--------------------	----------------------	---------------------------------	----------------	--

**ATTACHMENT B**  
**PROJECT ESTIMATE AND SOURCE OF FUNDS**  
 {Select} Performs PE Work or Hires Consultant / {Select} Lets Project for Construction

<b>Work Performed by Local Government ("LG")</b>							
<b>Description of Project Costs to be Incurred</b>	<b>Total Project Cost Estimate</b>	<b>Federal Participation</b> Includes percentage for TDC apportionment on projects where applicable		<b>State Participation</b> Includes authorized EDC amounts		<b>Local Government Participation</b> Includes authorized EDC reduction	
		<b>%</b>	<b>Cost</b>	<b>%</b>	<b>Cost</b>	<b>%</b>	<b>Cost</b>
Planning/Maps/Education/Non-CST	\$0	0%	\$0	0%	\$0	0%	\$0
Preliminary Engineering	\$0	0%	\$0	0%	\$0	0%	\$0
Environmental Cost	\$0	0%	\$0	0%	\$0	0%	\$0
Right of Way	\$0	0%	\$0	0%	\$0	0%	\$0
Utilities	\$0	0%	\$0	0%	\$0	0%	\$0
Construction Cost	\$1,112,761						
Construction Engineering Cost	\$						
Eligible In-Kind Contribution Value	\$						
<b>Total Construction Value</b> (sum of construction cost and in-kind value)	\$1,112,761	0%	\$890,209	0%	\$0	0%	\$222,552
<b>Work by LG Subtotal</b>	<b>\$1,112,761</b>		<b>\$890,209</b>		<b>\$0</b>		<b>\$222,552</b>
<b>Work Performed by the State (Local Participation paid up front by LG to TxDOT)</b>							
Preliminary Engineering <sup>1</sup>	\$0	0%	\$0	0%	\$0	0%	\$0
Environmental Cost <sup>1</sup>	\$0	0%	\$0	0%	\$0	0%	\$0
Right of Way <sup>3</sup>	\$0	0%	\$0	0%	\$0	0%	\$0
Utilities <sup>2</sup>	\$0	0%	\$0	0%	\$0	0%	\$0
Construction Cost <sup>2</sup>	\$						
Eligible In-Kind Contribution Value	\$						
<b>Total Construction Value</b> (sum of construction cost and in-kind value)	\$0	0%	\$0	0%	\$0	0%	\$0
<b>Work by State Subtotal</b>	<b>\$0</b>		<b>\$0</b>		<b>\$0</b>		<b>\$0</b>
<b>Direct and Indirect State Costs Incurred for Review, Inspection, Administration &amp; Oversight</b>							

CSJ #	0924-06-640	Project Name:	Magoffin Shared Use Path	AFA ID:	
-------	-------------	---------------	--------------------------	---------	--

Description of Project Costs to be Incurred	Total Project Cost Estimate	Federal Participation Includes percentage for TDC apportionment on projects where applicable		State Participation Includes authorized EDC amount		Local Government (LG) Participation Includes authorized EDC reduction	
		%	Cost	%	Cost	%	Cost
Preliminary Engineering <sup>1</sup>	\$38,390	80%	\$30,712	0%	\$0	20%	\$7,678
Environmental Cost <sup>1</sup>	\$30,712	80%	\$24,570	0%	\$0	20%	\$6,142
Right of Way <sup>1</sup>	\$7,678	80%	\$6,142	0%	\$0	20%	\$1,536
Utilities <sup>1</sup>	\$7,678	80%	\$6,142	0%	\$0	20%	\$1,536
Construction <sup>2</sup>	\$69,102	80%	\$55,282	0%	\$0	20%	\$13,820
Direct State Costs Subtotal	\$153,560	80%	\$122,848	0%	\$0	20%	\$30,712
Indirect State Cost	\$42,430		\$0	100%	\$42,430		\$0
<b>TOTAL PARTICIPATION</b>	<b>\$1,308,751</b>		<b>\$1,013,057</b>		<b>\$42,430</b>		<b>\$253,264</b>
In-kind Contribution Credit Applied						0%	\$0
<b>TOTAL REMAINING PARTICIPATION AFTER IN-KIND CONTRIBUTION</b>							<b>\$253,264</b>

- The estimated total participation by Local Government is \$253,264, plus 100% of overruns.
- Total estimated payment by Local Government to State is \$26,684.
- <sup>1</sup>Local Government's first payment of \$12,864 is due to State within 30 days from execution of this contract.
- <sup>2</sup>Local Government's second payment of \$13,820 is due to State within 60 days prior to the Construction contract being advertised for bids.
- <sup>3</sup>If ROW is to be acquired by State, Local Government's share of property cost will be due prior to acquisition.
- The local match must be 20% or greater and may include eligible in-kind contributions, EDC adjustments, or TDCs if authorized as part of project selection.
- Transportation Development Credits (TDC) are being utilized in place of the Local Government's participation in the amount of 0.
- This is an estimate; the final amount of Local Government participation will be based on actual costs.
- Maximum federal TASA funds available for Project are \$1,013,057.

This is a placeholder document: please  
upload your resolution materials in place of  
this document





---

File #: 22-971, Version: 1

---

**CITY OF EL PASO, TEXAS  
LEGISTAR AGENDA ITEM SUMMARY FORM**

**DISTRICT, DEPARTMENT, CONTACT INFORMATION:**

*Please choose District and Department from drop down menu. Please post exactly as example below.  
No Title's, No emails. Please use ARIAL 10 Font.*

**All Districts**

Purchasing and Strategic Sourcing, Claudia A. Garcia, (915) 212-1218  
Streets and Maintenance, Richard J. Bristol, (915) 212-7000

**AGENDA LANGUAGE:**

*This is the language that will be posted to the agenda. Please use ARIAL 11 Font.*

The linkage to the Strategic Plan is subsection 7.2 - Improve competitiveness through infrastructure improvements impacting the quality of life.

Request that the Purchasing Director be authorized to notify M.J. Mader Enterprises, Inc. dba Bio Dyne Chemical Co. that the City is terminating Contract No. 2022-0156 Motor Oil, Antifreeze, Lubricants, Transmission and Hydraulic Oils & Fluids for convenience, pursuant to the provisions and requirements of Part 4, Section 8, Paragraph A of the Contract Clauses, and that the termination shall be effective as of August 2, 2022.

**CITY OF EL PASO, TEXAS  
AGENDA ITEM  
DEPARTMENT HEAD'S SUMMARY FORM**

**AGENDA DATE:** August 2, 2022  
**PUBLIC HEARING DATE:** Not Applicable

**CONTACT PERSON(S) NAME AND PHONE NUMBER:**

Richard J. Bristol, Streets and Maintenance Director, (915) 212-7000  
Claudia A. Garcia, Interim Director of Purchasing & Strategic Sourcing, (915) 212-1218

**DISTRICT(S) AFFECTED:** All

**STRATEGIC GOAL:** No. 7 – Enhance and Sustain El Paso's Infrastructure Network

**SUBGOAL:** 7.2 – Improve competitiveness through infrastructure improvements impacting the quality of life

**SUBJECT:**

Request that the Purchasing Director be authorized to notify M.J. Mader Enterprises, Inc. dba Bio Dyne Chemical Co. that the City is terminating Contract No. 2022-0156 Motor Oil, Antifreeze, Lubricants, Transmission and Hydraulic Oils & Fluids for convenience, pursuant to the provisions and requirements of Part 4, Section 8, Paragraph A of the Contract Clauses, and that the termination shall be effective as of August 2, 2022.

**BACKGROUND / DISCUSSION:**

Price increase request was more than the allowed percentage by the contract.

**SELECTION SUMMARY:**

N/A

**CONTRACT VARIANCE:**

N/A

**PROTEST**

N/A

**PRIOR COUNCIL ACTION:**

On January 4, 2022, City Council approved the award of contract 2022-0156 Motor Oil, Antifreeze, Lubricants, Transmission and Hydraulic Oils & Fluids to M.J. Mader Enterprises, Inc dba Bio Dyne Chemical Co. for a one (1) year term and one (1) year-option to extend the contract for at total amount of \$1,345,593.00.

On June 7, 2022, City Council approved a change order to contract 2022-0156 Motor Oil, Antifreeze, Lubricants, Transmission and Hydraulic Oils & Fluids for an amount of \$67,600.90.

**AMOUNT AND SOURCE OF FUNDING:**

N/A

HAVE ALL AFFECTED DEPARTMENTS BEEN NOTIFIED?  YES  NO

PRIMARY DEPARTMENT: Streets and Maintenance

SECONDARY DEPARTMENT: Purchasing & Strategic Sourcing

---

\*\*\*\*\*REQUIRED AUTHORIZATION\*\*\*\*\*

DEPARTMENT HEAD:

  
Richard J. Bristol, Streets and Maintenance Director 7-25-22

**COUNCIL PROJECT FORM  
(Termination)**

\*\*\*\*\***POSTING LANGUAGE BELOW**\*\*\*\*\*

Please place the following item on the **CONSENT AGENDA** for the City Council Meeting of **August 2, 2022.**

**STRATEGIC GOAL: No. 7: Enhance and Sustain El Paso's Infrastructure Network**

The linkage to the Strategic Plan is subsection 7.2 – Improve competitiveness through infrastructure improvements impacting the quality of life.

Request that the Purchasing Director be authorized to notify M.J. Mader Enterprises, Inc. dba Bio Dyne Chemical Co. that the City is terminating Contract No. 2022-0156 Motor Oil, Antifreeze, Lubricants, Transmission and Hydraulic Oils & Fluids for convenience, pursuant to the provisions and requirements of Part 4, Section 8, Paragraph A of the Contract Clauses, and that the termination shall be effective as of August 2, 2022.



**RESOLUTION**

**WHEREAS**, on January 4, 2022, the City of El Paso ("City") awarded Contract No. 2022-0156 Motor Oil, Antifreeze, Lubricants, Transmission and Hydraulic Oils and Fluids to the following vendor:

I. M. J. Mader Enterprises, Inc. dba Bio-Dyne Chemical Co.

**WHEREAS**, pursuant to Part 4, Section 8, Paragraph A of the contract (Termination for Convenience) the City is authorized to terminate the Contract for convenience; and

**WHEREAS**, the City desires to terminate the Contract for Convenience.

**NOW, THEREFORE, BE IT RESOLVED BY CITY COUNCIL OF THE CITY OF EL PASO:**

That the Purchasing Director is authorized to notify M. J. Mader Enterprises, Inc. dba Bio-Dyne Chemical Co. that the City is terminating Contract No. 2022-0156 Motor Oil, Antifreeze, Lubricants, Transmission and Hydraulic Oils and Fluids for convenience, pursuant to the provisions and requirements of Part 4, Section 8, Paragraph A of the Contract Clauses, and that the termination shall be effective as of August 2, 2022.

**APPROVED** this \_\_\_\_\_ day of \_\_\_\_\_, 2022.

**THE CITY OF EL PASO:**

\_\_\_\_\_  
Oscar Lesser  
Mayor


**ATTEST:**

\_\_\_\_\_  
Laura D. Princ  
City Clerk

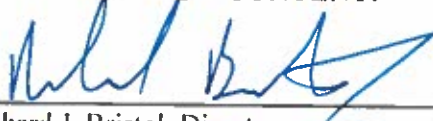
**APPROVED AS TO FORM:**

  
\_\_\_\_\_  
Juan S. Gonzalez  
Senior Assistant City Attorney

**APPROVED AS TO CONTENT:**

  
\_\_\_\_\_  
Claudia A. Garcia, Interim Director  
Purchasing and Strategic Sourcing

**APPROVED AS TO CONTENT:**

  
\_\_\_\_\_  
Richard J. Bristol, Director  
Streets and Maintenance Department



---

**File #: 22-961, Version: 1**

---

**CITY OF EL PASO, TEXAS  
LEGISTAR AGENDA ITEM SUMMARY FORM**

**DISTRICT, DEPARTMENT, CONTACT INFORMATION:**

*Please choose District and Department from drop down menu. Please post exactly as example below.  
No Title's, No emails. Please use ARIAL 10 Font.*

**All Districts**

Animal Services Department, Terry Kebschull, (915) 212-8742

**AGENDA LANGUAGE:**

*This is the language that will be posted to the agenda. Please use ARIAL 11 Font.*

A Resolution that the City Council designates the Director of the Department of Animal Services to be the Local Rabies Control Authority to enforce the provisions of the Texas Health and Safety Code, Section 826.017.

**CITY OF EL PASO, TEXAS  
AGENDA ITEM  
DEPARTMENT HEAD'S SUMMARY FORM**

**AGENDA DATE:**  
**PUBLIC HEARING DATE:**

**CONTACT PERSON(S) NAME AND PHONE NUMBER:**

**DISTRICT(S) AFFECTED:**

**STRATEGIC GOAL:**

**SUBGOAL:**

**SUBJECT:**

*APPROVE a resolution / ordinance / lease to do what? OR AUTHORIZE the City Manager to do what? Be descriptive of what we want Council to approve. Include \$ amount if applicable.*

**BACKGROUND / DISCUSSION:**

*Discussion of the what, why, where, when, and how to enable Council to have reasonably complete description of the contemplated action. This should include attachment of bid tabulation, or ordinance or resolution if appropriate. What are the benefits to the City of this action? What are the citizen concerns?*

**PRIOR COUNCIL ACTION:**

*Has the Council previously considered this item or a closely related one?*

**AMOUNT AND SOURCE OF FUNDING:**

*How will this item be funded? Has the item been budgeted? If so, identify funding source by account numbers and description of account. Does it require a budget transfer?*

**HAVE ALL AFFECTED DEPARTMENTS BEEN NOTIFIED? \_\_\_ YES \_\_\_ NO**

**PRIMARY DEPARTMENT:**

**SECONDARY DEPARTMENT:**

---

\*\*\*\*\***REQUIRED AUTHORIZATION**\*\*\*\*\*

**DEPARTMENT HEAD:** *Lory K Kebookull*

---

*(If Department Head Summary Form is initiated by Purchasing, client department should sign also)*

**RESOLUTION**

**WHEREAS**, the City has determined that it is in the best interest of the residents of the City of El Paso, Texas, and other governmental entities it contracts with, to make provisions for the designation of the local rabies control authority, in accordance with Texas Health and Safety Code, §826.017; and

**WHEREAS**, state law allows for the authority designated to be the county health officer, municipal health officer, animal control officer, peace officer or any entity the City Council considers appropriate; and

**WHEREAS**, City Council finds that the Director for the Department of Animal Services is eligible to be the Local Rabies Control Authority for the City of El Paso in accordance with the Texas Health and Safety Code, §826.017.

**NOW THEREFORE, BE IT RESOLVED BY THE CITY COUNCIL OF THE CITY OF EL PASO, TEXAS THAT:**

The City Council designates the Director for the Department of Animal Services to be the Local Rabies Control Authority to enforce the provisions of the Texas Health and Safety Code, §826.017.

*(Signatures appear on following page)*

**PASSED AND APPROVED** this \_\_\_\_ day of July 2022.

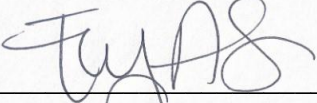
**CITY OF EL PASO**

\_\_\_\_\_  
Oscar Leeser, Mayor

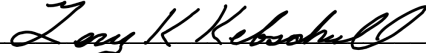
**ATTEST:**

\_\_\_\_\_  
Laura D. Prine  
City Clerk

**APPROVED AS TO FORM:**

  
\_\_\_\_\_  
Evy Sotelo  
Assistant City Attorney

**APPROVED AS TO CONTENT:**

  
\_\_\_\_\_  
Terry Kebschull, Director  
Department of Animal Services



---

File #: 22-964, Version: 1

---

**CITY OF EL PASO, TEXAS  
LEGISTAR AGENDA ITEM SUMMARY FORM**

**DISTRICT, DEPARTMENT, CONTACT INFORMATION:**

*Please choose District and Department from drop down menu. Please post exactly as example below.  
No Title's, No emails. Please use ARIAL 10 Font.*

**All Districts**

Community and Human Development, Nicole Ferrini, (915) 212-1659

**AGENDA LANGUAGE:**

*This is the language that will be posted to the agenda. Please use ARIAL 11 Font.*

A Resolution that the City Manager or designee be authorized to sign a Local Government Approval Letter for nonprofit organizations conducting Emergency Solutions Grant (ESG) Shelter Activities, approving the emergency shelter activities provided by El Paso Human Services, Inc. within the City of El Paso.

**CITY OF EL PASO, TEXAS  
AGENDA ITEM  
DEPARTMENT HEAD'S SUMMARY FORM**

**AGENDA DATE:** 8/2/2022 (Consent)

**PUBLIC HEARING DATE:** N/A

**CONTACT PERSON(S) NAME AND PHONE NUMBER:** Nicole Ferrini, 915-212-1659

**DISTRICT(S) AFFECTED:** All Districts

**STRATEGIC GOAL:** Goal 8 – Nurture and promote a healthy, sustainable community

**SUBGOAL:** 8.1 – Deliver prevention, intervention and mobilization services to promote a healthy, productive and safe community

**SUBJECT:**

**APPROVE a resolution / ordinance / lease to do what? OR AUTHORIZE the City Manager to do what? Be descriptive of what we want Council to approve. Include \$ amount if applicable.**

Resolution that the City Manager or designee be authorized to sign a local government approval letter for nonprofit organizations conducting emergency solutions grant (ESG) shelter activities, approving the emergency shelter activities provided by El Paso Human Services, Inc. within the City of El Paso.

**BACKGROUND / DISCUSSION:**

**Discussion of the what, why, where, when, and how to enable Council to have reasonably complete description of the contemplated action. This should include attachment of bid tabulation, or ordinance or resolution if appropriate. What are the benefits to the City of this action? What are the citizen concerns?**

Local nonprofit homeless service providers are eligible to apply to TDHCA for State administered Emergency Solutions Grant funding. As part of an application, nonprofits must acquire a letter from the City approving of the shelter activities to be provided under that funding. Following is a description of the shelter activities being applied for by El Paso Human Services, Inc. to TDHCA:

El Paso Human Services, Inc. runs the Winchester House Emergency Shelter located at 810 Montana, TX 79902. The shelter has been in operation for 10 years and serves male youth ages 18 to 24. The shelter provides overnight shelter, support services and case management to approximately 80 male youth on an annual basis. Individuals admitted to the shelter must meet the HUD definition of Homeless and must be male gender or identify as male gender. Young adults will have an average stay of less than 45 days at the dormitory style shelter and will be referred to El Paso Human Services' Rapid Rehousing, Transitional Housing or Permanent Supportive Housing programs. Case workers provide the youth with education/employment assistance, substance abuse counseling, mainstream benefits, and assistance in obtaining suitable housing placement based on each individual's needs. The funding request from TDHCA is in the amount of approximately \$189,000 for essential services and shelter operations.

Location of shelter activities: Winchester House, 810 Montana, El Paso, Texas 79902

**PRIOR COUNCIL ACTION:**

**Has the Council previously considered this item or a closely related one?**

N/A

**AMOUNT AND SOURCE OF FUNDING:**

**How will this item be funded? Has the item been budgeted? If so, identify funding source by account numbers and description of account. Does it require a budget transfer?**

Revised 04/09/2021

N/A

HAVE ALL AFFECTED DEPARTMENTS BEEN NOTIFIED?  YES  NO

PRIMARY DEPARTMENT: Department of Community + Human Development

SECONDARY DEPARTMENT: N/A

---

\*\*\*\*\*REQUIRED AUTHORIZATION\*\*\*\*\*

DEPARTMENT HEAD:



---

(If Department Head Summary Form is initiated by Purchasing, client department should sign also)



**RESOLUTION**

That the City Manager or designee be authorized to sign a Local Government Approval for Nonprofit Organizations Conducting ESG Shelter Activities letter approving the emergency shelter activities provided by El Paso Human Services, Inc., within the City of El Paso.

**NOW THEREFORE, BE IT RESOLVED BY THE CITY COUNCIL OF THE CITY OF EL PASO:**

**APPROVED** this \_\_\_\_\_ day of \_\_\_\_\_ 2022.


**THE CITY OF EL PASO:**

\_\_\_\_\_  
Oscar Leeser  
Mayor

**ATTEST:**

\_\_\_\_\_  
Laura D. Prine  
City Clerk

**APPROVED AS TO FORM:**

  
\_\_\_\_\_  
Joyce Garcia  
Assistant City Attorney

**APPROVED AS TO CONTENT:**

  
\_\_\_\_\_  
Nicole Ferrini, Director  
Community & Human Development



**2022 Emergency Solutions Grants (ESG) Program Annual Application**

**Local Government Approval for Nonprofit Organizations  
Conducting ESG Shelter Activities**

Name of ESG annual allocation Applicant: El Paso Human Services, Inc.

Brief description of proposed shelter activities: El Paso Human Services, Inc. runs the Winchester House Emergency Shelter located at 810 Montana, TX 79902. The shelter has been in operation for 10 years and serves male youth ages 18 to 24. We provide overnight shelter, support services and case management to approximately 80 male youth on an annual basis. Individuals admitted to the shelter must meet the HUD definition of Homeless and must be male gender or identify as male gender. Young adults will have an average stay of less than 45 days at the dormitory style shelter and will be referred to our agency Rapid Rehousing, Transitional Housing or Permanent Supportive Housing. Case workers provide them with education/employment assistance, substance abuse counseling, mainstream benefits, and in obtaining suitable housing placement based on each individual's needs. Funding requests from TDHCA is in the amount of approximately \$189,000 for Essential Services and Shelter Operations

Location of shelter activities: Winchester house, 810 Montana, El Paso, Texas 79902

**To be completed by the city or county:**

I, Nicole Ferrini, Chief Resilience Officer, duly authorized to act on behalf of the The City of El Paso, Texas, hereby approve the following emergency shelter activities proposed by the ESG Applicant listed on this form, which are to be located in this jurisdiction.

\_\_\_\_Nicole Ferrini\_\_\_\_\_

Name of Local Official Lead Agency Staff (*please print or type*)

\_\_\_\_\_

Signature of Local Official\*

Date

\_\_(915) 212-1659\_\_\_\_\_

Phone of Local Official

\_\_Ferrininm@elpasotexas.gov\_\_\_\_\_

Email of Local Official

\*County judge or mayor, or their official designee (such as city manager, assistant city manager, community development director or human services director). Each local government determines who has the authority to sign this document.



El Paso, TX

300 N. Campbell  
El Paso, TX

Legislation Text

---

**File #: 22-973, Version: 2**

---

**CITY OF EL PASO, TEXAS  
LEGISTAR AGENDA ITEM SUMMARY FORM**

**DISTRICT, DEPARTMENT, CONTACT INFORMATION:**

*Please choose District and Department from drop down menu. Please post exactly as example below.*

*No Title's, No emails. Please use ARIAL 10 Font.*

Members of the City Council, Representative Joe Molinar, (915) 212-0004

**AGENDA LANGUAGE:**

*This is the language that will be posted to the agenda. Please use ARIAL 11 Font.*

Eugenia Posada to the Bicycle Advisory Committee by Representative Joe Molinar, District 4.



# Board Appointment Form

Submitted On: Jul 20, 2022, 11:58AM MDT

City Clerk

<b>Appointing Office</b>	Representative District 4
<b>Type of Agenda</b>	Consent
<b>Date of Council Meeting</b>	Tuesday, August 2, 2022
<b>Agenda Posting Language</b>	Re-Appointment of Eugenia Posada to the Bicycle Advisory Committee by City Representative Joe Molinar, District 4.
<b>Name of Board/Committee/Commission</b>	Bicycle Advisory Committee
<b>Appointment Type</b>	Regular
<b>Special Qualification Category (if applicable)</b>	
<b>Nominated By</b>	Representative Joe Molinar
<b>Nominee Name</b>	Eugenia Posada
<b>Nominee Email Address</b>	[REDACTED]
<b>Nominee Mailing Address</b>	[REDACTED]
<b>Zip Code</b>	[REDACTED]
<b>Nominee Primary Phone Number</b>	[REDACTED]
<b>Does the proposed appointee have a relative working for the city?</b>	NO
<b>Has appointee been a member of other city boards / commissions / committees?</b>	YES
<b>If so, please provide names and dates.</b>	Bicycle Advisory Committee - July 20, 2021 - June 30, 2022 (Unexpired Term)
<b>List all real estate owned by appointee in El Paso County (by address, if none, enter 'N/A')</b>	[REDACTED]
<b>Who was the last person to have held the position before it became vacant?</b>	Eugenia Posada
<b>Incumbent Expiration Date</b>	June 30, 2022
<b>Reason person is no longer in office</b>	Term Expired
<b>Date of Appointment</b>	August 02, 2022
<b>Term begins on</b>	July 01, 2022
<b>Expiration Date of New Appointee</b>	June 30, 2024
<b>Term</b>	1st Term
<b>Upload File(s)</b>	Eugenia Posada - Resume - Bicycle Advisory Committee.docx

# Eugenia (Gina) Posada

---

## **Career Profile: Looking for an opportunity to work in a related field.**

Goal oriented, highly motivated with more than fifteen years of experience. Strong analytical, organizational and communication skills. Bilingual in English and Spanish.

## **Education**

### **DEGREE | DATE EARNED | SCHOOL**

- Master of Science in Psychology with Emphasis of Industrial and Organizational Psychology, May 2021  
Grand Canyon University
- Master of Business Administration: February 2004, University of Phoenix
- B.A. Liberal Arts in Psychology: December 2001, University of Texas at El Paso
- Minor in Sociology:
- Member of Golden Key Honor Society
- Member of Honor Society for Psychology
- Associate of Arts: December 1991, McComb Community College (Warren Michigan)
- Graduated Cum Laude

## **Experience**

### **RESEARCH PROGRAM COORDINATOR | UNIVERSITY OF TEXAS AT USTIN | JULY 2006-CURRENT**

- General knowledge of environmental concepts and state and federal environmental laws.
- Coordinates projects with bi-national organizations on a quarterly basis.
- Conducts and participates in technical meetings with international participants.
- Forms and establishes partnerships with environmental Mexican government regulatory entities.
- Forms and establishes partnerships with environmental government regulatory entities in the U.S.
- Works and collaborates with universities, community organizations and the public.
- Plans and organizes binational conferences, seminars, and/or training programs.
- Develops and translates bilingual agendas and minutes for binational environmental programs.
- Works in teams and multi-cultural settings.
- Fluent ability to speak, read and write Spanish.

### **GRANT FACILITATOR | CENTER FOR BORDER HEALTH RESEARCH | JUNE 2005-JULY 2006**

- Developed and maintained relationships among research stakeholders and community organizations.
- Participated in coalitions and networks at various levels relevant to CBHR.
- Performed continual funding search for internal and external needs.
- Investigated and tracked regional funding needs.
- Coordinated capacity building workshops for proposal development.
- Coordinated and organized workshops with US and Mexican entities.
- Presented the yearly Request for Proposals in Spanish.

- Provided a healthy working environment.
- Translated documents.

**ADMINISTRATIVE ASSISTANT | CENTER FOR BORDER HEALTH RESEARCH | JULY 2000-JUNE 2005**

- Managed administrative functions for the continuous growth of the Center.
- Assisted Director in the administration of Foundation grants in health research.
- Supported grant cycle monitoring.
- Coordinated Researcher Development Series activities in El Paso and Ciudad Juarez.
- Responsible for planning the new Recovery System by scanning and organizing all grant documents in the system to be used with Share Point.
- Maintained current access address database.
- Provided support for UTEP and CDC personnel housed at the Center.
- Developed and implemented grant cycle guide book.
- Coordinated and organized workshops with US and Mexican entities.
- Presented the yearly Request for Proposals in Spanish.
- Maintained a professional, pleasant, and healthy working environment.
- Translated documents.

**VOLUNTEER WORK | AMERICAN CANCER SOCIETY-CANCER ACTION NETWORK | SEPT. 2018-CURRENT**

- Nonpartisan advocacy to members of congress for better access to cancer care, prevention, early detection programs, cancer research funding, regulation of tobacco by USFDA, better quality of life for cancer patients, and attempts to raise awareness of and reduce cancer disparities.
- Fund raising event: Lights of Hope
- Representative Lead for El Paso.

**OTHER INTERESTS**

- Active living through yoga, cycling, walking, and jogging.
- Improving the environment and quality of life for the community.



El Paso, TX

300 N. Campbell  
El Paso, TX

Legislation Text

---

**File #: 22-993, Version: 2**

---

**CITY OF EL PASO, TEXAS  
LEGISTAR AGENDA ITEM SUMMARY FORM**

**DISTRICT, DEPARTMENT, CONTACT INFORMATION:**

*Please choose District and Department from drop down menu. Please post exactly as example below.*

*No Title's, No emails. Please use ARIAL 10 Font.*

Members of the City Council, Representative Aleksandra Annello, (915) 212-0002.

**AGENDA LANGUAGE:**

*This is the language that will be posted to the agenda. Please use ARIAL 11 Font.*

Rene Hurtado to the Greater El Paso Civic, Convention and Tourism Advisory Board by Representative Aleksandra Annello, District 2.





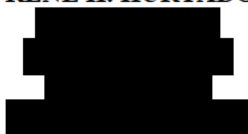
# Board Appointment Form

Submitted On: Jul 26, 2022, 10:59AM MDT

City Clerk

<b>Appointing Office</b>	Representative District 2
<b>Type of Agenda</b>	Consent
<b>Date of Council Meeting</b>	Tuesday, August 2, 2022
<b>Agenda Posting Language</b>	Appointment of Rene Hurtado to the Greater El Paso Civic, Convention and Tourism Advisory Board by City Representative Aleksandra Annello, District 2.
<b>Name of Board/Committee/Commission</b>	Greater El Paso Civic, Convention and Tourism Advisory Board
<b>Appointment Type</b>	Regular
<b>Special Qualification Category (if applicable)</b>	
<b>Nominated By</b>	Representative Aleksandra Annello
<b>Nominee Name</b>	Rene Hurtado
<b>Nominee Email Address</b>	██████████
<b>Nominee Mailing Address</b>	██████████
<b>Zip Code</b>	██████
<b>Nominee Primary Phone Number</b>	██████████
<b>Does the proposed appointee have a relative working for the city?</b>	NO
<b>Has appointee been a member of other city boards / commissions / committees?</b>	YES
<b>If so, please provide names and dates.</b>	Community Development Steering Committee from 6/25/19 to 6/14/22
<b>List all real estate owned by appointee in El Paso County (by address, if none, enter 'N/A')</b>	N/A
<b>Who was the last person to have held the position before it became vacant?</b>	Katherine R. Brennand
<b>Incumbent Expiration Date</b>	August 22, 2022
<b>Reason person is no longer in office</b>	Term Expired
<b>Date of Appointment</b>	August 02, 2022
<b>Term begins on</b>	August 22, 2022
<b>Expiration Date of New Appointee</b>	August 22, 2024
<b>Term</b>	1st Term
<b>Upload File(s)</b>	resume RH.doc

**RENE H. HURTADO**



**WORK EXPERIENCE**

**Emergence Health Network, El Paso, TX**

**4/08 to present**

**Chief of Staff**

Responsible for leading the organization in setting and implementing business development strategies and formulating policy initiatives that will raise awareness of Emergence Health Network and all services lines and business units for the largest provider of behavioral health services in the region. Responsible for all communication and feedback loop initiatives for key stakeholder publics. Areas of responsibility include: physician relations and recruitment, proforma development for new business lines, multi-year strategic plan management and internal/external communication strategy development. This role supervises the following departments and sections: Human Resources, Communications & Marketing, Customer Service, Media Relations, Government Relations, Social Media and Community Outreach Initiatives.

**Spectrum Communications, El Paso, TX**

**12/05 – 4/08**

**Director, Public Affairs**

Responsible for Spectrum's government relations and community relations programs. Worked with federal, state and local officials to educate and inform constituencies regarding telecommunications legislation. Oversaw the company's political action committee and works to educate workforce on governmental affairs issues. Also administered the company's charitable giving program focusing on education, the arts and economic development. Oversaw Spectrum's Cable in the Classroom initiative, as well as other outreach programs. Worked with local and national marketing teams to coordinate public relations and advertising efforts.

**Hospitals of Providence – Tenet Health, El Paso, TX**

**5/97 – 12/05**

**Director, Marketing & Communications - 10/00 to 12/05**

Responsible for the development and implementation of the hospital system's marketing and community relations initiatives. Supported all the system's business development activities to include advertising, payor relations and physician engagement. Coordinated the hospitals' response during internal/external crisis; Managed community events and hospital promotions to maximize positive image. Facilitated timely development of hospital press releases, news conferences, internal and external publications, brochures, invitations, posters and other collateral material. Served as media spokesman for the network. Also served as the network's physician recruiter, working with hospital administration and outside agencies to recruit physicians to the community.

**Media Relations Manager - 5/97 to 10/00**

Developed, implemented and updated Hospital of Providence's public relations programs to include auto-fax updates to physicians and employer / payor sectors. Maintained the System's positive image through media relations, internal and external publications aimed at employees, physicians and selected target markets. Facilitates participation on local community boards and Network-sponsored events and programs.

**University Medical Center, El Paso, TX**

**2/91 – 5/97**

**West Texas Regional Poison Center Education Coordinator - 11/94 to 5/97**

Developed and managed all education and marketing efforts throughout the Poison Center's 36-county operating area to include staff development, community, medical and professional educational

programs. Responsible for raising additional funds for the center's education program through grant writing and business sponsorships. Served as liaison to other educational and medical facilities.

Senior Public Affairs Specialist 3/94 to 11/94

Coordinated the production of all print materials for Thomason Hospital and oversaw day-to-day office operations to include data base budget management and inventory control. Assisted in the development of the hospital's marketing, public relations, health care advocacy and media relations initiatives.

Public Affairs Specialist – 2/91 to 3/94

Assisted in the coordination of public affairs activities for Thomason Hospital, including external and internal special events planning. Responsible for the production of all print materials for the hospital, including employee newsletter, internal communication and external patient education print materials.

## **EDUCATION**

University of Texas at El Paso

Master of Business Administration, 1996

Bachelor of Arts, 1990

Communications Major with an emphasis on public relations/advertising and general business minor

- Recipient of UTEP Presidential Scholarship
- Recipient of Scripps-Howard Academic Scholarship

## **COMMUNITY COMMITMENT**

- Leadership El Paso, Class 27 – 2005
- Chair, Greater El Paso Chamber of Commerce Government Relations Division, 2010
- Chair, Greater El Paso Chamber of Commerce Leadership El Paso, 2007
- Chair, Greater El Paso Chamber of Commerce Quality of Life Committee, 2006
- Chair Public Relations Committee, Board of Directors, Paso Del Norte Health Foundation (past service)
- Member, Advisory Board, El Paso 211
- Chair, National Communications Committee, National Association of County Behavioral Health Districts
- Member, Board of Trustees, County of El Paso Risk Pool Board
- Member, Board of Directors, Creative Kids (past service)
- Member, Creative Cities Leadership Group, City of El Paso, 2006-07
- Member, Government Advocacy Committee, El Paso Hispanic Chamber of Commerce (past service)
- Graduate, Mexican American Legal Defense Fund Leadership Program
- Member, Board of Directors, El Paso Chapter of the American Lung Association (past service)
- Member, Advisory Board, University of Texas at El Paso Department of Communications
- Executive Board Member, Public Relations Society of America, Rio Grande Chapter (past service)

## **LANGUAGES**

- Bilingual (English and Spanish)



El Paso, TX

300 N. Campbell  
El Paso, TX

Legislation Text

---

**File #: 22-1004, Version: 2**

---

**CITY OF EL PASO, TEXAS  
LEGISTAR AGENDA ITEM SUMMARY FORM**

**DISTRICT, DEPARTMENT, CONTACT INFORMATION:**

*Please choose District and Department from drop down menu. Please post exactly as example below.*

*No Title's, No emails. Please use ARIAL 10 Font.*

Members of the City Council, Representative Cissy Lizarraga, (915) 212-0008.

**AGENDA LANGUAGE:**

*This is the language that will be posted to the agenda. Please use ARIAL 11 Font.*

Holly Packard Cobb to the Greater El Paso Civic, Convention, and Tourism by Representative Cissy Lizarraga, District 8.



# Board Appointment Form

Submitted On: Jul 27, 2022, 10:54AM MDT

City Clerk

Appointing Office	Representative District 8
Type of Agenda	Consent
Date of Council Meeting	Tuesday, August 2, 2022
Agenda Posting Language	Appointment of Holly Packard Cobb to the Greater El Paso Civic, Convention, and Tourism by Representative Lizarraga, District 8.
Name of Board/Committee/Commission	Greater El Paso Civic, Convention and Tourism Advisory Board
Appointment Type	Regular
Special Qualification Category (if applicable)	
Nominated By	Representative Cissy Lizarraga
Nominee Name	Holly Packard Cobb
Nominee Email Address	[REDACTED]
Nominee Mailing Address	[REDACTED]
Zip Code	[REDACTED]
Nominee Primary Phone Number	[REDACTED]
Does the proposed appointee have a relative working for the city?	NO
Has appointee been a member of other city boards / commissions / committees?	NO
List all real estate owned by appointee in El Paso County (by address, if none, enter 'N/A')	[REDACTED]
Who was the last person to have held the position before it became vacant?	Elvira Galvan
Incumbent Expiration Date	August 20, 2022
Reason person is no longer in office	Term Expired
Date of Appointment	August 02, 2022
Term begins on	August 20, 2022
Expiration Date of New Appointee	August 20, 2024
Term	1st Term
Upload File(s)	Holly Cobb Resume- Greater El Paso Civic Convention and Tourism Advisory Board.docx

# HOLLY PACKARD COBB

  
Executive Director • Tom Lea Institute

---

## EXPERIENCE

Executive Director of the Tom Lea Institute since November 2019, Cobb was previously Vice President of Recruitment and Training for a division of Carter Hawley Hale Corporation. She then established a human resource consulting firm, The Packard Group, with seven partners who worked with national and international clients both in the private and governmental sectors.

## EDUCATION

- M.A. in Language Arts Curriculum Development & Leadership from UC Berkeley
- B.A. in English from U.C. Riverside.

## ACHIEVEMENTS

- Won numerous Telly Awards for her work in educational television, which combines animation, live studio production, and location filming. Has worked with Dr. Ken Blanchard, Zig Ziglar, and Franklin Graham. In addition, produced the television show Decision Point for KSCE TV. Under her leadership, TLI has broadened its mission to include curricula, heritage tourism, walking tours of El Paso and Juarez, and a destination weekend for visitors to experience the history and culture of El Paso.
- Expanded Tom Lea Institute's social media presence and engagement and has consistently increased revenue. Through the Institute, has developed heritage tourism with seven theme-based walking tours offered to the public and schools, trips to Mexico, hundreds of events in El Paso through Tom Lea Celebration, broadcasts and educational videos.



El Paso, TX

300 N. Campbell  
El Paso, TX

Legislation Text

---

**File #: 22-974, Version: 2**

---

**CITY OF EL PASO, TEXAS  
LEGISTAR AGENDA ITEM SUMMARY FORM**

**DISTRICT, DEPARTMENT, CONTACT INFORMATION:**

*Please choose District and Department from drop down menu. Please post exactly as example below.*

*No Title's, No emails. Please use ARIAL 10 Font.*

Members of the City Council, Representative Joe Molinar, (915) 212-0004.

**AGENDA LANGUAGE:**

*This is the language that will be posted to the agenda. Please use ARIAL 11 Font.*

Valerie M. Armendariz to the Tax Advisory Committee by Representative Joe Molinar, District 4.



# Board Appointment Form

Submitted On: Jul 20, 2022, 01:54PM MDT

City Clerk

<b>Appointing Office</b>	Representative District 4
<b>Type of Agenda</b>	Consent
<b>Date of Council Meeting</b>	Tuesday, August 2, 2022
<b>Agenda Posting Language</b>	Appointment of Valerie M. Armendariz to the Tax Advisory Committee by City Representative Joe Molinar.
<b>Name of Board/Committee/Commission</b>	Tax Advisory Committee
<b>Appointment Type</b>	Regular
<b>Special Qualification Category (if applicable)</b>	
<b>Nominated By</b>	Representative Joe Molinar
<b>Nominee Name</b>	Valerie M. Armendariz
<b>Nominee Email Address</b>	[REDACTED]
<b>Nominee Mailing Address</b>	[REDACTED]
<b>Zip Code</b>	[REDACTED]
<b>Nominee Primary Phone Number</b>	[REDACTED]
<b>Does the proposed appointee have a relative working for the city?</b>	NO
<b>Has appointee been a member of other city boards / commissions / committees?</b>	NO
<b>List all real estate owned by appointee in El Paso County (by address, if none, enter 'N/A')</b>	[REDACTED]
<b>Who was the last person to have held the position before it became vacant?</b>	Juan Antonio Reza
<b>Incumbent Expiration Date</b>	January 09, 2020
<b>Reason person is no longer in office</b>	Term Expired
<b>Date of Appointment</b>	August 02, 2022
<b>Term begins on</b>	January 09, 2020
<b>Expiration Date of New Appointee</b>	January 08, 2024
<b>Term</b>	1st Term
<b>Upload File(s)</b>	Valerie M. Armendariz - Resume - Tax Advisory Committee.pdf



# Valerie M. Armendariz

---

---

## Education

---

*Master's in Public Administration* Anticipated: December 2023  
The University of Texas at El Paso (UTEP)

*Bachelor of Psychology with a minor in Sociology*  
The University of Texas at El Paso (UTEP)

## Activities

Master's in Public Administration Student Association (MPASA)  
Officer: Secretary  
Fall 2021 – Present

## Work Experience

---

*Town Clerk* Anthony, Texas 79821  
Town Hall **March 2022 – Present**  
*Interim Town Clerk* Anthony, Texas 79821  
Town Hall **July 2021 – March 2022**  
*Deputy Town Clerk* Anthony, Texas 79821  
Town Hall **June 2019 – July 2021**

*Administrative Assistant* El Paso, Texas 79912  
Coronado County Club December 2017 – June 2019  
*Assistant Manager* Canutillo, Texas 79835  
Destination Maternity November 2016- June 2019

## Internship

---

*Program Intern and Event Photographer* El Paso, Texas 79901  
Make-A-Wish Foundation North Texas April 2014- December 2016  
January 2022-May 2022

## Skills

---

- Fluent in Spanish and English (Bilingual)
- Quickbooks Desktop
- ADP Payroll
- Microsoft Office
- Photoshop CS6



El Paso, TX

300 N. Campbell  
El Paso, TX

Legislation Text

---

**File #: 22-994, Version: 2**

---

**CITY OF EL PASO, TEXAS  
LEGISTAR AGENDA ITEM SUMMARY FORM**

**DISTRICT, DEPARTMENT, CONTACT INFORMATION:**

*Please choose District and Department from drop down menu. Please post exactly as example below.*

*No Title's, No emails. Please use ARIAL 10 Font.*

Members of the City Council, Representative Cassandra Hernandez, (915) 212-0003.

**AGENDA LANGUAGE:**

*This is the language that will be posted to the agenda. Please use ARIAL 11 Font.*

Elisa Morales to the Women's Rights Commission by Representative Cassandra Hernandez, District 3.



# Board Appointment Form

Submitted On: Jul 26, 2022, 02:48PM MDT

City Clerk

<b>Appointing Office</b>	Representative District 3
<b>Type of Agenda</b>	Consent
<b>Date of Council Meeting</b>	Tuesday, August 2, 2022
<b>Agenda Posting Language</b>	Appointment of Elisa Morales to the Women's Rights Commission by Representative Cassandra Hernandez, District 3
<b>Name of Board/Committee/Commission</b>	Women's Rights Commission
<b>Appointment Type</b>	Regular
<b>Special Qualification Category (if applicable)</b>	
<b>Nominated By</b>	Representative Cassandra Hernandez
<b>Nominee Name</b>	Elisa Morales
<b>Nominee Email Address</b>	[REDACTED]
<b>Nominee Mailing Address</b>	[REDACTED]
<b>Zip Code</b>	[REDACTED]
<b>Nominee Primary Phone Number</b>	[REDACTED]
<b>Does the proposed appointee have a relative working for the city?</b>	NO
<b>Has appointee been a member of other city boards / commissions / committees?</b>	NO
<b>List all real estate owned by appointee in El Paso County (by address, if none, enter 'N/A')</b>	[REDACTED]
<b>Who was the last person to have held the position before it became vacant?</b>	N/A New board
<b>Incumbent Expiration Date</b>	August 02, 2022
<b>Reason person is no longer in office</b>	Term Expired
<b>Date of Appointment</b>	August 02, 2022
<b>Term begins on</b>	September 01, 2022
<b>Expiration Date of New Appointee</b>	August 31, 2024
<b>Term</b>	1st Term
<b>Upload File(s)</b>	Elisa Morales - Resume - Women's Rights Commission - 8.2.22.pdf

# ELISA ANDREA MORALES

Service

Convener

Leadership

## Work History

### **Federal Reserve Bank of Dallas El Paso Branch – Outreach Advisor El Paso, TX April 2022 – Present**

- Responsible for convening stakeholders, coalescing timely economic data and presentation materials.
- Identify strategic opportunities to highlight the human capital and thought leadership among the District 11 executives and subject matter experts.
- Promote the Federal Reserve Bank of Dallas Economic Education curriculum among Southern New Mexico, El Paso, and West Texas education stakeholders.

### **Texas Department of State Health Services – Program Specialist VII El Paso & Austin, TX December 2020 – April 2022**

- Supported the Commissioner in the Executive Operations and Support Office by: providing timely reports on programs, draft speeches, talking points, presentations, and track and provide updates on legislatively mandated reports.
- Researched and analyzed public health trends – including SARS-CoV-2 – and provide updates to the Commissioner and Associate Commissioners and create communications tools for stakeholder groups.

### **United Way of El Paso County – Director El Paso, TX November 2017 – January 2020**

- Directed a bi-national, U.S. Mexico Border, and multi-state (Texas, New Mexico, and Chihuahua) upstream preventative public health initiative.
- Responsibilities included: grantee management, outreach to stakeholders, provide quality capacity building for stakeholders, contract management, support coalition and network activities, oversee bilingual and regional public relations strategies, create a regional policy agenda, and leveraged earned media to promote initiative.

### **Office of U.S. Senator Tom Udall (NM) – Aide Washington, D.C. May 2016–August 2016**

- Managed legislative portfolio: Health, Education, Indian Health System, Bureau of Indian Education, Social Security, Postal Service, and Appropriations. Work closely with State staff on well-being priorities.
- Met with stakeholders, interfaced with federal agencies, analyzed and drafted legislation, developed recommendations, briefed and staffed the Senator for committee hearings.

### **Congressional Hispanic Caucus Institute - Congressional Fellow Washington, D.C., August 2015 – May 2016**

- Leadership and Policy program: worked in two Congressional offices on bipartisan health and education issues, capstone project included a white paper and Congressional Briefing on ‘Curative and Palliative Care: The Ethical and Economic Considerations of a Person-Centered Health Care Paradigm.’

*Senate Committee on Health, Education, Labor & Pensions, Senator Lamar Alexander (TN)*

- Health Policy Team: Research specialist in area of public health (Zika, Health IT, Mental Health, 21<sup>st</sup> Century Cures, Mental Health Insurance Parity), assist in preparing for Senate HELP Committee Hearings and Mark-Ups.

*Office of Representative 'Beto' O'Rourke (TX-16)*

- Assisted Health Legislative Assistant with research and drafting health care policy positions, attend briefings and hearings.

**El Paso Behavioral Health System –Liaison                      El Paso, TX                      October 2014 – August 2015**

- Mental health liaison between police department, school districts, and hospitals; outreach to community partners to present on stigma reducing programs and education; assisted in planning of new outpatient clinic.
- Responsible for business development opportunities across all service segments, administrative reporting to CEO and COO, and represent hospital at national Service Excellence Leadership Trainings.

**VITAS Hospice – Community Liaison                      San Antonio, TX                      July 2013 – May 2014**

- Increased patient census by marketing to referral sources in targeted communities for sustainable business growth.
- Delivered End Of Life Care presentations to community members and health providers.

**Medtronic Diabetes, Inc. – Diabetes Associate                      San Antonio, TX                      June 2011 – July 2013**

- Increased patient census by marketing to referral sources in targeted communities for sustainable business growth.

**University of Texas Health Science Center San Antonio – Research                      January 2006 – May 2011**

- Didactic implementation of a lifestyle intervention for a longitudinal study via behavior modification to participants in clinical, home, and community settings.
- Part of a cross functional team, provided case management, reporting, analysis of data, publish study findings, and present data and anecdotal tools in national conferences.
- Facilitated recidivism prevention intervention to pre-adjudicated youth in Bexar County Juvenile Probation.

**Hispanic Scholarship Fund –Coordinator                      San Antonio, TX                      May 2007 - August 2009**

- Directed three statewide scholarship and peer mentoring programs in San Antonio, College Station, and Houston.
- Partnered with UTSA office of P-20 Initiatives, local school districts, non-profits, and donors relations.

## **Professional Development & Volunteerism**

**League of Women Voters of El Paso – Member                      El Paso, TX                      2018 - Present**  
**Big Brothers Big Sisters of El Paso – Big Sister                      El Paso, TX                      January 2019 – 2021**  
**American Association of Retired People – Tax Site Facilitator                      El Paso, TX                      Jan. 2017-2021**

- Recruit and organize volunteers for tax preparation events, maintain communications and engagement of volunteers.

**Congressional Hispanic Caucus Institute–Reviewer                      Washington, D.C.                      Feb. 2017–2020**

- Review applications to the Graduate Fellowship Program, and conducted online interviews with candidates.

- Quijotes Medical Mission Trip –Volunteer Oaxaca, Oaxaca, Mexico Sept. 2016-2019**
- Oversee the operations of the Optical Clinic and processed more than 1,000 patient visits.
- Korn Ferry HayGroup - Leadership Trainee Washington, D.C. June 2017**
- Completed 20 hours of online based leadership development course.
- Japanese Embassy Leadership Program – Fellow Japan Spring 2016**
- Cultural and policy immersion program in Tokyo and Hiroshima, Japan.
- Executive Office of the D.C. Mayor – Office on Latino Affairs, Grant Reviewer Washington, D.C. December 2015**
- Volunteer grant reviewer for grants, and reauthorizations, in the amounts of \$10,000-\$50,000.
- American Heart Association – Health Equity San Antonio, TX Jan. 2010 – August 2012**
- Health advocate, and did community based education around heart and stroke campaigns.
- National Latina Health Network –Advocate Washington, D.C. June 2010 –May 2012**
- Emerging Leaders Health Institute Student Fellow and contract employee; presented at national conferences on health disparities (shift work disorder, diabetes, heart disease, and diaper deprivation).
- Free Trade Alliance – Future Global Leaders Coalition San Antonio, TX 2010 - 2012**
- International Business Plan Competition: Conducted market research, comprehensive SWOT and value-chain analysis, 5 year financial forecasting for Seno Medical and Spain-based Enertis Solar.

## Education

- American University Washington College of Law – Washington, D.C. – Certificate Aril 2016**
- Non-Profit Board Governance Certificate Program
- Texas A&M University - San Antonio - Masters of Business Administration May 2012**
- Study Abroad Seminar in Brazil – Bio Diversity and Urban Planning, Summer 2012
  - Study Abroad Seminar in Ireland – Technology Clusters, Summer 2011
- The University of Texas at San Antonio - Bachelor of Liberal Arts in Psychology & Criminal Justice May 2007**
- Federal Bureau of Investigation Internship Program (Security Clearance) – San Antonio Field Office, Spring 2007
  - Hispanic Scholarship Fund – Awarded a stipend to mentor low income students June 2006 – May 2007



El Paso, TX

300 N. Campbell  
El Paso, TX

Legislation Text

---

**File #: 22-1005, Version: 2**

---

**CITY OF EL PASO, TEXAS  
LEGISTAR AGENDA ITEM SUMMARY FORM**

**DISTRICT, DEPARTMENT, CONTACT INFORMATION:**

*Please choose District and Department from drop down menu. Please post exactly as example below.*

*No Title's, No emails. Please use ARIAL 10 Font.*

Members of the City Council, Representative Cissy Lizarraga, (915) 212-0008.

**AGENDA LANGUAGE:**

*This is the language that will be posted to the agenda. Please use ARIAL 11 Font.*

Nydia Correa to the Women's Right Commission by Representative Cissy Lizarraga, District 8.



# Board Appointment Form

Submitted On: Jul 27, 2022, 11:31AM MDT

City Clerk

<b>Appointing Office</b>	Representative District 8
<b>Type of Agenda</b>	Consent
<b>Date of Council Meeting</b>	Tuesday, August 2, 2022
<b>Agenda Posting Language</b>	Apoinment of Nydia Correa to the Women's Right Commission by Representative Lizarraga, District 8
<b>Name of Board/Committee/Commission</b>	Women's Rights Commission
<b>Appointment Type</b>	Regular
<b>Special Qualification Category (if applicable)</b>	
<b>Nominated By</b>	Representative Cissy Lizarraga
<b>Nominee Name</b>	Nydia Correa
<b>Nominee Email Address</b>	[REDACTED]
<b>Nominee Mailing Address</b>	[REDACTED]
<b>Zip Code</b>	[REDACTED]
<b>Nominee Primary Phone Number</b>	[REDACTED]
<b>Does the proposed appointee have a relative working for the city?</b>	NO
<b>Has appointee been a member of other city boards / commissions / committees?</b>	NO
<b>List all real estate owned by appointee in El Paso County (by address, if none, enter 'N/A')</b>	[REDACTED]
<b>Who was the last person to have held the position before it became vacant?</b>	VACANT
<b>Incumbent Expiration Date</b>	August 20, 2024
<b>Reason person is no longer in office</b>	Term Expired
<b>Date of Appointment</b>	August 02, 2022
<b>Term begins on</b>	August 20, 2022
<b>Expiration Date of New Appointee</b>	August 20, 2024
<b>Term</b>	1st Term
<b>Upload File(s)</b>	N. Correa Resume_Bio for Women's Commission.docx.pdf



# Nydia P. Correa



## Employment Experience:

- Current: Guiding Star El Paso - Financial Manager Consultant
- Guiding Star El Paso (Formerly House of Hope) - Executive Director
- AVANCE - Executive Director
- RC Properties - Owner Operator/Manager
- EDRO Entertainment - Owner Operator/Finance Manager
- El Paso Electric - Regulatory Accountant
- Continental Airlines - Financial Analyst
- Perez & Company Realtors - Agent / Manager

## Educational Background:

- University of Texas of El Paso - Bachelor of Business, double major in Finance and Real Estate

## Community Service:

- Board of Directors:
  - Guiding Star Project National
  - Southwest Coalition
  - Ronald McDonald House
- Various Community and Faith-based committees

Nydia Correa, the recent past Executive Director of Guiding Star El Paso, is a native El Pasoan and a proud graduate of the University of Texas at El Paso. She is blessed to be married to her husband Roland of 32 years and a mother of 3 children, ages 27, 23, and 16. Mrs. Correa has 38 years of business experience in both the corporate profit and non-profit sectors, with a concentration in finance and management. Her professional experience includes working in finance with a major airline, entrepreneurial business endeavors, and start-ups.

With a growing vision and mission in mind, she led House of Hope, a pregnancy resource center established in 2002, to affiliate with a national organization, The Guiding Star Project, and established Guiding Star El Paso, a comprehensive, holistic women's and family healthcare center. She feels honored and privileged that her years as a businesswoman, volunteer, mother, and wife can be used to empower women, men, and families in her local community and beyond.



El Paso, TX

300 N. Campbell  
El Paso, TX

Legislation Text

---

**File #: 22-955, Version: 1**

---

**CITY OF EL PASO, TEXAS  
LEGISTAR AGENDA ITEM SUMMARY FORM**

**DISTRICT, DEPARTMENT, CONTACT INFORMATION:**

*Please choose District and Department from drop down menu. Please post exactly as example below.  
No Title's, No emails. Please use ARIAL 10 Font.*

**All Districts**

Tax Office, Maria O. Pasillas, (915) 212-1737

**AGENDA LANGUAGE:**

*This is the language that will be posted to the agenda. Please use ARIAL 11 Font.*

That the tax refunds listed on the attachment posted with this agenda be approved. This action would allow us to comply with state law which requires approval by the legislative body of refunds of tax overpayments greater than \$2,500.00. (See Attachment A)

TAX REFUNDS  
August 2, 2022

1. Corelogic, in the amount of \$3,138.40 made an overpayment on December 20, 2021 of 2021 taxes.  
(Geo. # S373-999-002A-1100)
2. Citiso Investments, LLC, in the amount of \$19,887.78 made an overpayment on June 29, 2022 of 2021 taxes.  
(Geo. # S560-000-0004-0007)

---

Laura D. Prine  
City Clerk

  
\_\_\_\_\_  
Maria O. Pasillas, RTA  
Tax Assessor Collector

**CITY OF EL PASO, TEXAS  
AGENDA ITEM  
DEPARTMENT HEAD'S SUMMARY FORM**

**AGENDA DATE:** August 2, 2022  
**PUBLIC HEARING DATE:** N/A

**CONTACT PERSON(S) NAME AND PHONE NUMBER:** Maria O. Pasillas, (915) 212-1737

**DISTRICT(S) AFFECTED:** All

**STRATEGIC GOAL:** Goal 6 – Set the Standard for Sound Governance and Fiscal Management

**SUBGOAL:** 6.11 Provide efficient and effective services to taxpayers

**SUBJECT:**

**APPROVE** a resolution / ordinance / lease to do what? **OR AUTHORIZE** the City Manager to do what? **Be descriptive of what we want Council to approve. Include \$ amount if applicable.**

That the tax refunds listed on the attachment posted with this agenda be approved. This action would allow us to comply with state law which requires approval by the legislative body of refunds of tax overpayments greater than \$2,500.00. (See Attachment A)

**BACKGROUND / DISCUSSION:**

Discussion of the what, why, where, when, and how to enable Council to have reasonably complete description of the contemplated action. This should include attachment of bid tabulation, or ordinance or resolution if appropriate. What are the benefits to the City of this action? What are the citizen concerns?

Approve property tax overpayment refunds greater than \$2,500.00, per the Texas Property Tax Code, Sec. 31.11 – Refunds of Overpayments or Erroneous Payments.

**PRIOR COUNCIL ACTION:**

**Has the Council previously considered this item or a closely related one?**

Council has considered this previously on a routine basis.

**AMOUNT AND SOURCE OF FUNDING:**

**How will this item be funded? Has the item been budgeted? If so, identify funding source by account numbers and description of account. Does it require a budget transfer?**

**HAVE ALL AFFECTED DEPARTMENTS BEEN NOTIFIED?   X   YES    NO**

**PRIMARY DEPARTMENT:** Tax Office  
**SECONDARY DEPARTMENT:** N/A

---

\*\*\*\*\*REQUIRED AUTHORIZATION\*\*\*\*\*

**DEPARTMENT HEAD:**



(If Department Head Summary Form is initiated by Purchasing, client department should sign also)



TAX OFFICE RECEIVED

JUL 11 2022

MARIA O. PASILLAS, RTA  
CITY OF EL PASO TAX ASSESSOR COLLECTOR  
221 N. KANSAS, STE 300  
EL PASO, TX 79901

PH: (915) 212-0106 FAX: (915) 212-0107 Email: taxforms@elpasotexas.gov

CORELOGIC  
PO BOX 9205  
COPELL, TX 75019-9214

OP ✓  
+2,500

<b>Geo No.</b> S373-999-002A-1100	<b>Prop ID</b> 291221
<b>Legal Description of the Property</b> 2-A SIERRA DEL SOL REPLAT B SLY PT OF 11 30.58 FT ON ROW 111.48 FT ON N 98.19 FT ON E 139.11 FT ON S (7499 SQ FT)	
760 ESPADA DR-A	
OWNER: BECKER SEYMOUR & JOAN	
<b>2021 OVERAGE AMOUNT \$3,138.40</b>	

1: CITY OF EL PASO, 3: EL PASO ISD, 6: COUNTY OF EL PASO, 7: EL PASO COMMUNITY COLLEGE, 8: UNIVERSITY MEDICAL CENTER OF EL PASO

Dear Taxpayer:

Our records indicate that an overpayment exists on the property tax account listed above as of the date of this letter. If you paid the taxes on this account and believe you are entitled to a refund, please complete the application below, sign it, and return it to our office. If the taxes were paid by your mortgage/title company or any other party, you must obtain a written letter of release in order for the refund to be issued in your name. If you did not make the payment(s) on this account, please forward this letter to the person who paid these taxes. You may also request the transfer of this overpayment to other tax accounts and/or tax years in the space provided or by attaching an additional sheet if necessary. Your application for refund must be submitted within three years from the date of the overpayment, or you waive the right to the refund (Sec. 31.11c). Governing body approval is required for refunds in excess of \$2500.

**APPLICATION FOR PROPERTY TAX REFUND:**

This application must be completed, signed, and submitted with supporting documentation to be valid.

<b>Step 1. Identify the refund recipient.</b> Show information for whomever will be receiving the refund.	Who should the refund be issued to:			
	Name: CORELOGIC			
	Address: Centralized Refunds P.O Box 9202 ✓			
	City, State, Zip: Coppell, TX 75019			
Daytime Phone No.:		E-Mail Address: gramkrishnareddy@corelogic.com		
<b>Step 2. Provide payment information.</b> Please attach copy of cancelled check, original receipt, online payment confirmation or bank/credit card statement.	Payment made by:	Check No.	Date Paid	Amount Paid
	corelogic	95191290 001 003	12/20/2021	\$3138.40
	<b>TOTAL AMOUNT PAID (sum of the above amounts)</b>			\$3138.40
<b>Step 3. Provide reason for this refund.</b> Please list any accounts and/or years that you intended to pay with this overage.	Please check one of the following:			
	<input checked="" type="checkbox"/> I paid this account in error and I am entitled to the refund. corelogic paid in error for this account ✓			
	<input type="checkbox"/> I overpaid this account. Please refund the excess to the address listed in Step 1.			
	<input type="checkbox"/> I want this payment applied to next year's taxes.			
<input type="checkbox"/> This payment should have been applied to other tax account(s) and/or year(s), escrow (listed below):				
<b>Step 4. Sign the form.</b> Unsigned applications cannot be processed.	By signing below, I hereby apply for the refund of the above-described taxes and certify that the information I have given on this form is true and correct. ( If you make a false statement on this application, you could be found guilty of a Class A misdemeanor or a state jail felony under the Texas Penal Code, Sec. 37.10. )			
	SIGNATURE OF REQUESTOR (REQUIRED) CL:gramkrishnareddy		PRINTED NAME & DATE Girish 7/11/2022 ✓	
TAX OFFICE USE ONLY: <input checked="" type="checkbox"/> Approved <input type="checkbox"/> Denied By: NN Date: 7-13-22 ✓				



Notes

Go To

LUZR  
ACT80122 v1.91

07/14/2022 13:25:23  
ACTEP

DEPOSIT Remittance Detail

Summary Query

Summary

Deposit No	Account No	Remit Seq No	Check No	Payment Amount	Payment Agreement No.
M21800000001	S373999002A1100				

Check/Receipt Images	Deposit No.	Receipt Date	Remit Seq No.	Check No.	Payment Type	Payment Amount	Applied Amount	Transaction Type	Account No	Payer
	EC052322	05/22/2022	50638846	CC004505932	EC	\$784.61	\$784.61	PA	S373999002A1100	31301456-ROBERTA KLIK
	EC032122	03/20/2022	50392053	CC004434916	EC	\$784.61	\$784.61	PA	S373999002A1100	31156248-ROBERTA ANN
	A01132275	01/13/2022	49176506	6562	CH	\$784.61	\$784.61	PA	S373999002A1100	BECKER SEYMOUR & JC
	<b>M21800000001</b>	<b>12/20/2021</b>	<b>48571144</b>	<b>RG2112172054</b>	<b>EF</b>	<b>274,189,766.61</b>	<b>\$3,138.40</b>	<b>PA</b>	<b>S373999002A1100</b>	<b>800000-CORELOGIC</b>
	R030122767	12/20/2021	48571144	RG2112172054	EF	\$0.00	\$3,138.40	LG	S373999002A1100	800000-CORELOGIC
	R030122767	12/20/2021	48571144	RG2112172054	EF	\$0.00	\$3,138.40	TR	S373999002A1100	800000-CORELOGIC
	RC220713	12/20/2021	48571144	RG2112172054	EF	\$3,138.40	\$3,138.40	TR	S373999002A1100	26322876-CORELOGIC
	RC220713	12/20/2021	48571144	RG2112172054	EF	\$3,138.40	\$3,138.40	TR	S373999002A1100	800000-CORELOGIC
	EC07262185	07/26/2021	47642483	CC003818886	EC	\$751.98	\$751.98	PA	S373999002A1100	29936526-JOAN BECKEF
	EC05262185	05/26/2021	47449984	CC003769156	EC	\$752.01	\$752.01	PA	S373999002A1100	29834382-IVR PAYMENT
	EC03242185	03/24/2021	47167674	CC003693897	EC	\$752.01	\$752.01	PA	S373999002A1100	29677158-IVR PAYMENT
	EC01192198	01/18/2021	46103005	CC003433738	EC	\$752.01	\$752.01	PA	S373999002A1100	29186828-IVR PAYMENT
<b>Applied Total</b>							<b>\$65,277.00</b>			

1124# 207633

OPV  
+2,500

THE CITY OF EL PASO CONSOLIDATED TAX OFFICE

221 N. Kansas, Suite 300

El Paso, Texas 79901

Phone (915) 212-0106, Fax (915) 212-0108, Email: taxforms@elpasotexas.gov

JUL 12 2022

APPLICATION FOR TAX REFUND

The Consolidated Tax Office collects property taxes for all eligible property taxing entities within El Paso County.

APPLICANT MUST PROVIDE THE FOLLOWING INFORMATION:

Refund To: Citiso Investments, LLC ✓	Phone: HOME: 9158514035 WORK:	Property ID# (One application per account) S56000000040007
-----------------------------------------	-------------------------------------	---------------------------------------------------------------

Address (mail refund to :) P.O. BOX 600 Clint, TX 79836 ✓	Property Address: And/or Legal Description: 10149 Conquistador Socorro, TX 79927 Lot 7, Block 4, Spanish Trail
-----------------------------------------------------------------	----------------------------------------------------------------------------------------------------------------------

Tax year requested:	Date payment made:	Check No. & Date, if known:		Amount of taxes paid:	Amount of refund requested:
1. 2014 thru 2020	6/29/2022	EFT	6/30/2022	21,828.03	19,887.78 ✓
2.					
3.					

TOTAL AMOUNT (sum of the above amounts)

(City Council approval required if over \$2,500)

REQUIRED: Copy of original receipt, front & back of negotiated check, OR bank statement showing item cleared (both the bank & taxpayer name must appear)

REASON FOR OVERPAYMENT: I tried paying 2021, but it did not give me a choice on the amount I wanted to pay. The property was acquired through the sheriff tax sale and taxes for 2014 through 2020 included in the judgement and startin bid.

See judgement

The only amount owed was for 2021.

"I certify that information given to obtain this refund is true and correct."

*[Signature]*

Date: 07/08/2022

Requestor signature:

Sonia Rubio

Business Administrator ✓

Printed name:

Title:

Any person knowingly submitting false entries is subject to: (1) Imprisonment of 2 to 10 years, or \$5,000 fine, or both. (2) Imprisonment up to one year, or fine not over \$2,000, or both. (Sec 37.10 Penal Code) An application for a refund must be made within 3 years after the date of the payment or the taxpayer waives the right to the refund (Sec. 31.11 (c)).

TAX OFFICE Entry:

(✓) REFUND APPROVED

Tax Office Approval:

*[Signature]* N.A.  
JUL 7-19-22

Date: 7-13-22 ✓

Date:

(Placed on City Council Agenda over \$2,500)

- ( ) DISAPPROVED
- ( ) Returned to sender
- ( ) See below/attached
- ( ) Required documentation (Tax receipt, Canceled Check, Bank Statement, or Other) not submitted.
- ( ) Record of overpayment not found on this property.
- ( ) Property not found as identified, resubmit after correction.
- ( ) Other: \_\_\_\_\_



Notes

Go To

LUZR  
ACT80122 v1.91

ACCOUNT NO (S56000000040007) SOLD AT JUNE 2022 TAX SALE

07/19/2022 14:19:00  
ACTEP

DEPOSIT Remittance Detail

Summary Query

Summary

Deposit No.	Account No.	Remit Seq No.	Check No.	Payment Amount	Payment Agreement No.					
EC062922	S56000000040007									
Check/Receipt Images	Deposit No.	Receipt Date	Remit Seq No.	Check No.	Payment Type	Payment Amount	Applied Amount	Transaction Type	Account No.	Payer
	EC062922	06/29/2022	50763370	CC004540093	EC	\$21,828.03	\$21,828.03	PA	S56000000040007	31374967-CITISO INVEST
	R030722185	06/29/2022	50763370	CC004540093	EC	\$0.00	\$2,564.47	TR	S56000000040007	31374967-CITISO INVEST
	R030722185	06/29/2022	50763370	CC004540093	EC	\$0.00	\$2,262.42	LG	S56000000040007	31374967-CITISO INVEST
	R030722185	06/29/2022	50763370	CC004540093	EC	\$0.00	\$245.00	LG	S56000000040007	31374967-CITISO INVEST
	R030722185	06/29/2022	50763370	CC004540093	EC	\$0.00	\$2,329.20	LG	S56000000040007	31374967-CITISO INVEST
	R030722185	06/29/2022	50763370	CC004540093	EC	\$0.00	\$2,215.81	LG	S56000000040007	31374967-CITISO INVEST
	R030722185	06/29/2022	50763370	CC004540093	EC	\$0.00	\$245.00	TR	S56000000040007	31374967-CITISO INVEST
	R030722185	06/29/2022	50763370	CC004540093	EC	\$0.00	\$300.00	LG	S56000000040007	31374967-CITISO INVEST
	R030722185	06/29/2022	50763370	CC004540093	EC	\$0.00	\$13.00	TR	S56000000040007	31374967-CITISO INVEST
	R030722185	06/29/2022	50763370	CC004540093	EC	\$0.00	\$2,032.82	TR	S56000000040007	31374967-CITISO INVEST
	R030722185	06/29/2022	50763370	CC004540093	EC	\$0.00	\$313.00	TR	S56000000040007	31374967-CITISO INVEST
	R030722185	06/29/2022	50763370	CC004540093	EC	\$0.00	\$313.00	LG	S56000000040007	31374967-CITISO INVEST
Applied Total							\$32,112.63			



El Paso, TX

300 N. Campbell  
El Paso, TX

Legislation Text

---

**File #: 22-956, Version: 1**

---

**CITY OF EL PASO, TEXAS  
LEGISTAR AGENDA ITEM SUMMARY FORM**

**DISTRICT, DEPARTMENT, CONTACT INFORMATION:**

*Please choose District and Department from drop down menu. Please post exactly as example below.  
No Title's, No emails. Please use ARIAL 10 Font.*

**All Districts**

Tax Office, Maria O. Pasillas, (915) 212-1737

**AGENDA LANGUAGE:**

*This is the language that will be posted to the agenda. Please use ARIAL 11 Font.*

That the tax refunds listed on the attachment posted with this agenda be approved. This action would allow us to comply with state law which requires approval by the legislative body of refunds of tax overpayments exceeding the three (3) year limit. (See Attachment B)

TAX REFUNDS OVER THREE (3) YEARS  
August 2, 2022

1. Mills Escrow Company, in the amount of \$675.82, made an overpayment on December 31, 2017 of 2017 taxes.  
(Geo. # E948-000-0050-1000)
2. Mills Escrow Company, in the amount of \$424.50, made an overpayment on January 31, 2019 of 2018 taxes.  
(Geo. # E948-000-0070-1500)
3. Mills Escrow Company, in the amount of \$16.95, made an overpayment on January 25, 2019 of 2018 taxes.  
(Geo. # M074-999-0010-1300)
4. Mills Escrow Company, in the amount of \$34.53, made an overpayment on January 31, 2019 of 2018 taxes.  
(Geo. # M326-000-0040-1600)
5. Mills Escrow Company, in the amount of \$26.35, made an overpayment on January 31, 2019 of 2018 taxes.  
(Geo. # M326-000-0020-3400)

---

Laura D. Prine  
City Clerk



---

Maria O. Pasillas, RTA  
Tax Assessor Collector

**CITY OF EL PASO, TEXAS  
AGENDA ITEM  
DEPARTMENT HEAD'S SUMMARY FORM**

**AGENDA DATE:** August 2, 2022  
**PUBLIC HEARING DATE:** N/A

**CONTACT PERSON(S) NAME AND PHONE NUMBER:** Maria O. Pasillas, (915) 212-1737

**DISTRICT(S) AFFECTED:** All

**STRATEGIC GOAL:** Goal 6 – Set the Standard for Sound Governance and Fiscal Management

**SUBGOAL:** 6.11 Provide efficient and effective services to taxpayers

**SUBJECT:**

**APPROVE** a resolution / ordinance / lease to do what? **OR AUTHORIZE** the City Manager to do what? Be descriptive of what we want Council to approve. Include \$ amount if applicable.

That the tax refunds listed on the attachment posted with this agenda be approved. This action would allow us to comply with state law which requires approval by the legislative body of refunds of tax overpayments exceeding the three (3) year limit. (See Attachment B)

**BACKGROUND / DISCUSSION:**

Discussion of the what, why, where, when, and how to enable Council to have reasonably complete description of the contemplated action. This should include attachment of bid tabulation, or ordinance or resolution if appropriate. What are the benefits to the City of this action? What are the citizen concerns?

Approve property tax overpayment refunds exceeding the statutory three (3) year limit, per the Texas Property Tax Code, Sec. 31.11 – Refunds of Overpayments or Erroneous Payments.

**PRIOR COUNCIL ACTION:**

**Has the Council previously considered this item or a closely related one?**

Council has considered this previously on a routine basis.

**AMOUNT AND SOURCE OF FUNDING:**

How will this item be funded? Has the item been budgeted? If so, identify funding source by account numbers and description of account. Does it require a budget transfer?

**HAVE ALL AFFECTED DEPARTMENTS BEEN NOTIFIED?**  YES  NO

**PRIMARY DEPARTMENT:** Tax Office  
**SECONDARY DEPARTMENT:** N/A

\*\*\*\*\*REQUIRED AUTHORIZATION\*\*\*\*\*

**DEPARTMENT HEAD:**



(If Department Head Summary Form is initiated by Purchasing, client department should sign also)



# Internal Audit Office

**MAYOR**  
Oscar Leaser

**DATE:** April 26, 2022

**TO:** Maria O. Pasillas, Tax Assessor/Collector

**CITY COUNCIL**

**FROM:** Edmundo S. Calderon, CIA, CGAP, CRMA, Chief Internal Auditor 

**District 1**  
Peter Svarzbein

**SUBJECT:** Review of Tax Overpayment Refunds that Exceed Three Years

**District 2**  
Alexandra Anello

The Internal Audit Office conducted a review of the Tax Overpayment Refunds that exceeded a three-year period. This engagement was accepted based on the engagement’s potential to improve management of risks, add value, and/or improve the organization’s operations (IIA 2010.C1). The work performed does not constitute an engagement conducted in accordance with Generally Accepted Government Auditing Standards (GAS 1.16). The observations and conclusions that are reported in this memorandum do not require Management responses.

**District 3**  
Cassandra Hernandez

**District 4**  
Joe Molinar

The following Tax Overpayment Refund that exceeded a three-year period was reviewed:

**District 5**  
Isabel Salcido

MILLS ESCROW COMPANY	E948-000-0050-1000	\$675.82
MILLS ESCROW COMPANY	E948-000-0070-1500	\$424.50
MILLS ESCROW COMPANY	M074-999-0010-1300	\$16.95

**District 6**  
Claudia L. Rodriguez

**District 7**  
Henry Rivera

The Internal Audit Office reviewed the refund applications, copies of cancelled checks or proof of payments. Attached is a list of days from the date the completed applications were received by the Tax Office and sent to the Internal Audit Office for review. The Tax Office is taking 1 day to process the applications received and send for review.

**District 8**  
Cissy Lizarraga

Based on our review, the Tax Overpayment Refunds that exceeded a three-year period were determined to be appropriate to send to City Council for approval pursuant to Section 31.11 (c-1) of the Texas Tax Code.

**CITY MANAGER**  
Tommy Gonzalez

cc: Tomas Gonzalez, City Manager  
Robert Cortinas, Deputy City Manager of Support Services & Chief Financial Officer

**Edmundo S. Calderon – Chief Internal Auditor**  
Internal Audit Office | 218 N. Campbell | El Paso, TX 79901  
O: (915) 212-0069 | Email: calderones@elpasotexas.gov

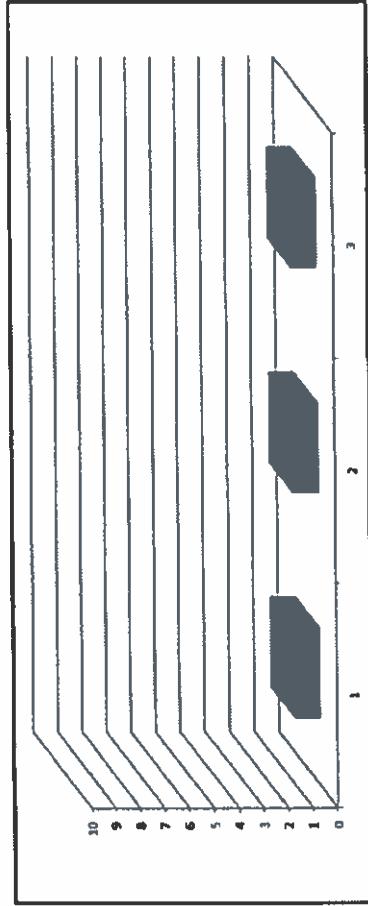




City of El Paso  
Internal Audit Office  
Tax Office Refund Project  
Week of 04/18/2022 Reviews- Over Three Years

Refund To	P.I.D. Number	Amount of Refund	Date Application was Received	Date of Proof of Payment was Received in our Tax Office	Date Application was approved by the Tax Office	Date Tax Office Sent to Internal Audit for Review	Tickets Sent from Date Proof of Payment to Date Internal Audit is to Review	Date Internal Audit Reviewed Application	Comments
1 MILLS ESCROW COMPANY	E948-000-0030-1000	\$675.82	4/18/2022	4/21/2022	4/22/2022	4/22/2022		4/26/2022	
2 MILLS ESCROW COMPANY	E948-000-0070-1500	\$ 424.50	4/18/2022	4/21/2022	4/22/2022	4/22/2022		4/26/2022	
3 MILLS ESCROW COMPANY	NB74-999-0010-1300	\$16.95	4/18/2022	4/21/2022	4/22/2022	4/22/2022		4/26/2022	
		<b>\$1,117.27</b>							

**Legend**  
■ 0-10 Days  
■ 11-20 Days  
■ 21-30 Days  
■ 01-10 Days



**RESOLUTION**

**WHEREAS**, pursuant to Section 31.11 (c) of the Texas Code an application for a refund must be made within three (3) years after the date of the payment or the taxpayer waives the right to the refund; and

**WHEREAS**, pursuant to Section 31.11 (c-1) the governing body of the taxing unit may extend the deadline for a single period not to exceed two years on a showing of good cause by the taxpayer; and

**WHEREAS**, taxpayer, Mills Escrow Company (“Taxpayer”) has applied for a refund with the tax assessor for their 2017 property taxes that were overpaid on December 31, 2017 in the amount of \$675.82 for all taxing entities; and

**WHEREAS**, City Council may extend the deadline for the Taxpayer’s application for the overpayment of the 2017 taxes for a period not to exceed two years on a showing of good cause by the taxpayer; and

**NOW, THEREFORE, BE IT RESOLVED BY THE CITY COUNCIL OF THE CITY OF EL PASO:**

THAT THE City finds that Mills Escrow Company showed a good cause to extend the deadline to apply for a refund of the overpayment of the 2017 taxes and the tax refund in the amount of \$675.82 is approved.

**APPROVED this \_\_\_\_\_ day of \_\_\_\_\_, 2022.**

**CITY OF EL PASO:**

\_\_\_\_\_  
Oscar Leeser  
Mayor

**ATTEST:**

\_\_\_\_\_  
Laura D. Prine  
City Clerk

**APPROVED AS TO FORM:**

*Wendi N. Vineyard*

\_\_\_\_\_  
Wendi N. Vineyard  
Assistant City Attorney

**APPROVED AS TO CONTENT:**

*Maria O. Pasillas*

\_\_\_\_\_  
Maria O. Pasillas, RTA  
Tax Assessor/Collector



MARIA O. PASILLAS, RTA  
CITY OF EL PASO TAX ASSESSOR COLLECTOR  
221 N. KANSAS, STE 300  
EL PASO, TX 79901

TAX OFFICE  
RECEIVED  
APR 21 2022

PH: (915) 212-0106 FAX: (915) 212-0107 www.elpasotexas.gov/tax-office

Geo No. E948-000-0050-1000	Prop ID 628979
Legal Description of the Property BLK 5 ESTANCIAS DE MISIONES LOT 10 13395 ESTANCIAS DEL SUR RD 79849	
OWNER: ALVARADO ELIZABETH & RUEDAS CHRISTOBAN	
2017 OVERAGE AMOUNT \$675.82	

MILLS ESCROW COMPANY  
6501 BOEING STE. H-4  
EL PASO, TX 79925

OP  
+ 3 yrs

6: COUNTY OF EL PASO. 7: EL PASO COMMUNITY COLLEGE, 8: UNIVERSITY MEDICAL CENTER OF EL PASO, 19: SAN ELIZARIO ISD, 25: LWR VALLEY WTR DISTRICT, 27: EMERG. SERVICES DIST #2, 56: CITY OF SAN ELIZARIO

Dear Taxpayer:

Our records indicate that an overpayment exists on the property tax account listed above as of the date of this letter. If you paid the taxes on this account and believe you are entitled to a refund, please complete the application below, sign it, and return it to our office. If the taxes were paid by your mortgage/title company or any other party, you must obtain a written letter of release in order for the refund to be issued in your name. If you did not make the payment(s) on this account, please forward this letter to the person who paid these taxes. You may also request the transfer of this overpayment to other tax accounts and/or tax years in the space provided or by attaching an additional sheet if necessary. Your application for refund must be submitted within three years from the date of the overpayment, or you waive the right to the refund (Sec. 31.11c). Governing body approval is required for refunds in excess of \$2500.

APPLICATION FOR PROPERTY TAX REFUND: This application must be completed, signed, and submitted with supporting documentation to be valid.

Step 1. Identify the refund recipient. Show information for whomever will be receiving the refund.	Who should the refund be issued to:			
	Name: MILLS ESCROW COMPANY			
	Address: PO Box 371805			
	City, State, Zip: El Paso, TX 79937-1805			
Step 2. Provide payment information. Please attach copy of cancelled check, original receipt, online payment confirmation or bank/credit card statement.	Daytime Phone No.:	(915) 774-8000	E-Mail Address:	millsescrow.co
	Payment made by:	Check No.	Date Paid	Amount Paid
	Mills Escrow	068596	12/31/17	\$49,246.03
TOTAL AMOUNT PAID (sum of the above amounts)				
Step 3. Provide reason for this refund. Please list any accounts and/or years that you intended to pay with this overage.	Please check one of the following:			
	<input type="checkbox"/>	I paid this account in error and I am entitled to the refund.		
	<input checked="" type="checkbox"/>	I overpaid this account. Please refund the excess to the address listed in Step 1.		
	<input type="checkbox"/>	I want this payment applied to next year's taxes.		
This payment should have been applied to other tax account(s) and/or year(s), escrow (listed below):				
Step 4. Sign the form. Unsigned applications cannot be processed.	By signing below, I hereby apply for the refund of the above-described taxes and certify that the information I have given on this form is true and correct. ( If you make a false statement on this application, you could be found guilty of a Class A misdemeanor or a state jail felony under the Texas Penal Code, Sec. 37.10. )			
	SIGNATURE OF REQUESTOR (REQUIRED)		PRINTED NAME & DATE	
	[Signature]		Veronica Sepulveda 4/18/22	
TAX OFFICE USE ONLY:	<input checked="" type="checkbox"/> Approved	<input type="checkbox"/> Denied	By: N.H.	Date: 4-22-22



THIS DOCUMENT HAS A TRUE WATERMARK, AND CAN BE SEEN WHEN HELD TO LIGHT. THIS PAPER IS ALTERATION PROTECTED.

**MILLS ESCROW COMPANY**

**TRUST ACCOUNT**  
6501 BOEING, STE. H-4  
EL PASO, TX 79925  
(915) 771-8006

CITY BANK  
EL PASO, TX 79913  
18-172 70  
1113

No. **068596**

CHECK NO  
68596

DATE AMOUNT  
12/29/2017 \$49,246.03

---Forty Nine Thousand Two Hundred Forty Six and 03/100---

PAY TO THE ORDER OF  
Tax Assessor Collector  
PO Box 2992  
El Paso, TX 79999-2992

*1/5/2018*

*+33*

*Jacqueline Miles*

THIS PAPER CONTAINS VISIBLE AND INVISIBLE FIBERS FACE AND BACK WHICH FLUORESCCE UNDER ULTRAVIOLET LIGHT.

⑈068596⑈ ⑆111301737⑆ 70214272⑈

Check 68596 Amount \$49,246.03 Date 1/5/2018

TAX OFFICE  
RECEIVED  
APR 21 2022

Notes

Go To: [dropdown]

NANCYH  
ACT80122 v1.91

05/26/2022 13:22:06  
ACTEP

DEPOSIT Remittance Detail

Summary Query

Summary

Deposit No.	Account No.	Remit Seq No.	Check No.	Payment Amount	Payment Agreement No.
B01031875	E94800000501000				

Check/Receipt Images	Deposit No.	Receipt Date	Remit Seq No.	Check No.	Payment Type	Payment Amount	Applied Amount	Transaction Type	Account No.	Payer
	A01182201	01/18/2022	49248019	004538	CH	\$91,285.20	\$1,902.75	PA	E94800000501000	25959829-TEXSTAR ESC
	A12212065	12/21/2020	45381163	2930	CH	\$47,775.19	\$1,770.18	AA	E94800000501000	25959829-TEXSTAR ESC
	A01022081	12/30/2019	42566594	001570	CH	\$34,145.77	\$1,546.55	PA	E94800000501000	3905-TEXSTAR ESCROW
	A01251986	01/25/2019	40184268	070683	CH	\$92,639.62	\$1,365.99	PA	E94800000501000	1512117-MILLS ESCROW
	B01031875	12/31/2017	36678009	068596	CH	\$49,246.03	\$675.82	LG	E94800000501000	20376420-MILLS ESCROW
	B01031875	12/31/2017	36678009	068596	CH	\$49,246.03	\$1,331.90	AA	E94800000501000	20376420-MILLS ESCROW
	RC220422	12/31/2017	36678009	068596	CH	\$675.82	\$675.82	TR	E94800000501000	20376420-MILLS ESCROW
	RC220422	12/31/2017	36678009	068596	CH	\$675.82	\$675.82	TR	E94800000501000	428-MILLS ESCROW CO
	A12151641	12/15/2016	33348594	66215	CH	\$88,201.27	\$1,236.81	AA	E94800000501000	1512117-MILLS ESCROW
	A12091565	12/09/2015	30199210	62729	CH	\$30,185.70	\$1,235.51	AA	E94800000501000	428-MILLS ESCROW CO
	A07071565	06/30/2015	29370800	62213	CH	\$3,488.78	\$837.25	AA	E94800000501000	1512117-MILLS ESCROW
	B02051565	01/31/2015	28603890	61610	CH	\$12,956.93	\$26.93	AA	E94800000501000	20936953-MILLS ESCROW

Applied Total \$13,431.27

**RESOLUTION**

**WHEREAS**, pursuant to Section 31.11 (c) of the Texas Code an application for a refund must be made within three (3) years after the date of the payment or the taxpayer waives the right to the refund; and

**WHEREAS**, pursuant to Section 31.11 (c-1) the governing body of the taxing unit may extend the deadline for a single period not to exceed two years on a showing of good cause by the taxpayer; and

**WHEREAS**, taxpayer, Mills Escrow Company through Ramirez Perla C (“Taxpayer”) has applied for a refund with the tax assessor for their 2018 property taxes that were overpaid on January 31, 2019 in the amount of \$424.50 for all taxing entities; and

**WHEREAS**, City Council may extend the deadline for the Taxpayer’s application for the overpayment of the 2018 taxes for a period not to exceed two years on a showing of good cause by the taxpayer; and

**NOW, THEREFORE, BE IT RESOLVED BY THE CITY COUNCIL OF THE CITY OF EL PASO:**

THAT THE City finds that Mills Escrow Company through showed a good cause to extend the deadline to apply for a refund of the overpayment of the 2018 taxes and the tax refund in the amount of \$424.50 is approved.

**APPROVED** this \_\_\_\_\_ day of \_\_\_\_\_, 2022.

**CITY OF EL PASO:**

\_\_\_\_\_  
Oscar Leeser  
Mayor

**ATTEST:**

\_\_\_\_\_  
Laura D. Prine  
City Clerk

**APPROVED AS TO FORM:**

*Wendi N. Vineyard*

\_\_\_\_\_  
Wendi N. Vineyard  
Assistant City Attorney

**APPROVED AS TO CONTENT:**

*Maria O. Pasillas*

\_\_\_\_\_  
Maria O. Pasillas, RTA  
Tax Assessor/Collector



TAX OFFICE RECEIVED  
APR 21 2022



MARIA O. PASILLAS, RTA  
CITY OF EL PASO TAX ASSESSOR COLLECTOR  
221 N. KANSAS, STE 300  
EL PASO, TX 79901

PH: (915) 212-0106 FAX: (915) 212-0107 www.elpasotexas.gov/tax-office

RAMIREZ PERLA C  
1312 FOUR WHEEL DR  
SAN ELIZARIO, TX 79849

OP ✓  
+ 3 yrs

Geo No. E948-000-0070-1500	Prop ID 629040
Legal Description of the Property BLK 7 ESTANCIAS DE MISIONES LOT 15	
13301 ESTANCIAS DE MISION RD 79849	
OWNER: AGUILAR MELODY I	
2018 OVERAGE AMOUNT \$424.50	

6. COUNTY OF EL PASO, 7. EL PASO COMMUNITY COLLEGE, 8. UNIVERSITY MEDICAL CENTER OF EL PASO, 19. SAN ELIZARIO ISD, 25. LWR VALLEY WTR DISTRICT, 27. EMERG. SERVICES DIST. #2, 56. CITY OF SAN ELIZARIO

Dear Taxpayer:

Our records indicate that an overpayment exists on the property tax account listed above as of the date of this letter. If you paid the taxes on this account and believe you are entitled to a refund, please complete the application below, sign it, and return it to our office. If the taxes were paid by your mortgage/title company or any other party, you must obtain a written letter of release in order for the refund to be issued in your name. If you did not make the payment(s) on this account, please forward this letter to the person who paid these taxes. You may also request the transfer of this overpayment to other tax accounts and/or tax years in the space provided or by attaching an additional sheet if necessary. Your application for refund must be submitted within three years from the date of the overpayment, or you waive the right to the refund (Sec. 31.11c). Governing body approval is required for refunds in excess of \$2500.

APPLICATION FOR PROPERTY TAX REFUND: This application must be completed, signed, and submitted with supporting documentation to be valid.

<b>Step 1. Identify the refund recipient.</b> Show information for whomever will be receiving the refund.	Who should the refund be issued to:			
	Name: MILLS ESCROW COMPANY			
	Address: PO Box 371805			
	City, State, Zip: El Paso, TX 79937-1805		E-Mail Address:	
<b>Step 2. Provide payment information.</b> Please attach copy of cancelled check, original receipt, online payment confirmation or bank/credit card statement.	Daytime Phone No.:		E-Mail Address:	
	Payment made by:	Check No.	Date Paid	Amount Paid
	Mills Escrow	070738	11/31/2019	\$ 5,790.44
	<b>TOTAL AMOUNT PAID (sum of the above amounts)</b>			
<b>Step 3. Provide reason for this refund.</b> Please list any accounts and/or years that you intended to pay with this overage.	Please check one of the following:			
	<input type="checkbox"/>	I paid this account in error and I am entitled to the refund.		
	<input checked="" type="checkbox"/>	I overpaid this account. Please refund the excess to the address listed in Step 1.		
	<input type="checkbox"/>	I want this payment applied to next year's taxes.		
<b>Step 4. Sign the form.</b> Unsigned applications cannot be processed	This payment should have been applied to other tax account(s) and/or year(s), escrow (listed below):			
	By signing below, I hereby apply for the refund of the above-described taxes and certify that the information I have given on this form is true and correct. ( If you make a false statement on this application, you could be found guilty of a Class A misdemeanor or a state jail felony under the Texas Penal Code, Sec. 37.10. )			
	SIGNATURE OF REQUESTOR (REQUIRED)		PRINTED NAME & DATE	
June 4/22/22		Veronica Sepulveda 4/18/22		
TAX OFFICE USE ONLY: <input checked="" type="checkbox"/> Approved <input type="checkbox"/> Denied By: N.H. Date: 4-22-22				

NUMBER: 70738

AMOUNT: 5790.44

THIS DOCUMENT HAS A TRUE WATERMARK AND CAN BE SEEN WHEN HELD TO LIGHT. THIS PAPER IS ALTERATION PROTECTED.

**MILLS ESCROW COMPANY  
TRUST ACCOUNT**

6501 BOEING, STE. H-4  
EL PASO, TX 79925  
(915) 771-8006

CITY BANK  
EL PASO, TX 79912  
18-173 70  
1113

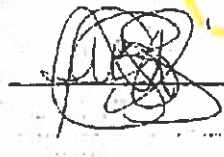
No. **070738**

CHECK NO.  
70738

DATE	AMOUNT
1/18/2019	\$5,790.44

—Five Thousand Seven Hundred Ninety and 44/100—

PAY TO THE ORDER OF  
Tax Assessor Collector  
PO Box 2992  
El Paso, TX 79909-2992



THIS PAPER CONTAINS VISIBLE AND INVISIBLE FIBERS FACE AND BACK WHICH FLUORESCCE UNDER ULTRAVIOLET LIGHT.

⑈070738⑈ ⑆66630⑆37⑆ 70264272⑈

Account: XXXXXX4272  
Number: 70738

Date: 02-11-2019  
Amount: 5790.44

TAX OFFICE  
RECEIVED  
APR 21 2022

Notes

Go To :

NANCYH  
ACT80122 v1.91

05/26/2022 13:13:21  
ACTEP

DEPOSIT Remittance Detail

Summary Query

Summary

Deposit No.	Account No.	Remit Seq No.	Check No.	Payment Amount	Payment Agreement No.					
X0208192001	E94800000701500									
Check/Receipt Images	Deposit No.	Receipt Date	Remit Seq No.	Check No.	Payment Type	Payment Amount	Applied Amount	Transaction Type	Account No.	Payer
	A01182201	01/18/2022	49247602	004539	CH	\$26,426.96	\$563.18	PA	E94800000701500	25959829-TEXSTAR ESC
	A12212065	12/21/2020	45386669	2935	CH	\$55,568.18	\$175.39	PA	E94800000701500	25959829-TEXSTAR ESC
	EC12162098	12/16/2020	45320577	CC003286981	EC	\$417.38	\$417.38	PA	E94800000701500	28915682-CHICKEN RAN
	B02072075	01/31/2020	43677554	2851	CH	\$580.32	\$580.32	PA	E94800000701500	22383176-CHICKEN RAN
	RC210825	01/31/2019	40730833	70738	CH	\$424.50	\$424.50	TR	E94800000701500	RAMIREZ PERLA C
	RC210825	01/31/2019	40730833	70738	CH	\$424.50	\$424.50	TR	E94800000701500	28131070-MILLS ESCROV
	RC220422	01/31/2019	40730833	70738	CH	\$424.50	\$424.50	TR	E94800000701500	28131070-MILLS ESCROV
	RC220422	01/31/2019	40730833	70738	CH	\$424.50	\$424.50	TR	E94800000701500	428-MILLS ESCROW COM
	X0208192001	01/31/2019	40730833	70738	CH	\$5,790.44	\$424.50	LG	E94800000701500	RAMIREZ PERLA C
	A01251986	01/25/2019	40185674	070677	CH	\$32,261.29	\$582.49	PA	E94800000701500	1512117-MILLS ESCROW
	A03271878	03/27/2018	38054657	2195	CH	\$259.27	\$259.27	PA	E94800000701500	CHICKEN RANCH ROAD J
	A01251875	01/25/2018	37244521	2135	CH	\$5,437.02	\$405.23	AA	E94800000701500	22383176-CHICKEN RAN
<b>Applied Total</b>							\$5,834.90			



**RESOLUTION**

**WHEREAS**, pursuant to Section 31.11 (c) of the Texas Code an application for a refund must be made within three (3) years after the date of the payment or the taxpayer waives the right to the refund; and

**WHEREAS**, pursuant to Section 31.11 (c-1) the governing body of the taxing unit may extend the deadline for a single period not to exceed two years on a showing of good cause by the taxpayer; and

**WHEREAS**, taxpayer, Mills Escrow Company ("Taxpayer") has applied for a refund with the tax assessor for their 2018 property taxes that were overpaid on January 25, 2019 in the amount of \$16.95 for all taxing entities; and

**WHEREAS**, City Council may extend the deadline for the Taxpayer's application for the overpayment of the 2018 taxes for a period not to exceed two years on a showing of good cause by the taxpayer; and

**NOW, THEREFORE, BE IT RESOLVED BY THE CITY COUNCIL OF THE CITY OF EL PASO:**

THAT THE City finds that Mills Escrow Company showed a good cause to extend the deadline to apply for a refund of the overpayment of the 2018 taxes and the tax refund in the amount of \$16.95 is approved.

**APPROVED** this \_\_\_\_\_ day of \_\_\_\_\_, 2022.

**CITY OF EL PASO:**

\_\_\_\_\_  
Oscar Leoser  
Mayor

**ATTEST:**

\_\_\_\_\_  
Laura D. Prine  
City Clerk

**APPROVED AS TO FORM:**

*Wendi N. Vineyard*

\_\_\_\_\_  
Wendi N. Vineyard

**APPROVED AS TO CONTENT:**

*Maria O. Pasillas*  
\_\_\_\_\_  
Maria O. Pasillas, RTA

Assistant City Attorney

Tax Assessor/Collector

22-1002-777.001|1185223  
Tax Refund Request Resolution | Mills Escrow Company (2018) \$16.95  
WNV





TAX OFFICE RECEIVED  
APR 21 2022

MARIA O. PASILLAS, RTA  
CITY OF EL PASO TAX ASSESSOR COLLECTOR  
221 N. KANSAS, STE 300  
EL PASO, TX 79901

PH: (915) 212-0106 FAX: (915) 212-0107 www.elpasotexas.gov/tax-office

MILLS ESCROW CO  
6501 BOEING, STE H-4  
EL PASO, TX 79925

OP ✓  
+ 3 yrs

Geo No. M074-999-0010-1300	Prop ID 644865
Legal Description of the Property LOT 13 BLK I MARAVILLA MANUFACTURED HOME COMMUNITY CONDOMINIUM PLUS 0.8547 % INT IN COM AREA (4990.00 SQ FT)	
9849 ALAMEDA AVE-G-34 79927	
OWNER: CHAVEZ JOSE L & MARIA L	
2018 OVERAGE AMOUNT \$16.95	

1: CITY OF EL PASO, 5: YSLETA ISD, 6: COUNTY OF EL PASO, 7: EL PASO COMMUNITY COLLEGE, 8: UNIVERSITY MEDICAL CENTER OF EL PASO

Dear Taxpayer:

Our records indicate that an overpayment exists on the property tax account listed above as of the date of this letter. If you paid the taxes on this account and believe you are entitled to a refund, please complete the application below, sign it, and return it to our office. If the taxes were paid by your mortgage/title company or any other party, you must obtain a written letter of release in order for the refund to be issued in your name. If you did not make the payment(s) on this account, please forward this letter to the person who paid these taxes. You may also request the transfer of this overpayment to other tax accounts and/or tax years in the space provided or by attaching an additional sheet if necessary. Your application for refund must be submitted within three years from the date of the overpayment, or you waive the right to the refund (Sec. 31.11c). Governing body approval is required for refunds in excess of \$2500.

APPLICATION FOR PROPERTY TAX REFUND: This application must be completed, signed, and submitted with supporting documentation to be valid.

<b>Step 1. Identify the refund recipient.</b> Show information for whomever will be receiving the refund.	Who should the refund be issued to:			
	Name: <b>MILLS ESCROW COMPANY</b>			
	Address: <b>PO Box 371805</b>			
	City, State, Zip: <b>El Paso, TX 79937-1805</b>			
Daytime Phone No.:		E-Mail Address:		
<b>Step 2. Provide payment information.</b> Please attach copy of cancelled check, original receipt, online payment confirmation or bank/credit card statement.	Payment made by:	Check No.	Date Paid	Amount Paid
	<i>Mills Escrow</i>	<i>070707</i>	<i>1/25/19</i>	<i>\$26,374.37</i>
	<b>TOTAL AMOUNT PAID (sum of the above amounts)</b>			
<b>Step 3. Provide reason for this refund.</b> Please list any accounts and/or years that you intended to pay with this overage.	Please check one of the following:			
	<input type="checkbox"/> I paid this account in error and I am entitled to the refund.			
	<input checked="" type="checkbox"/> I overpaid this account. Please refund the excess to the address listed in Step 1. ✓			
	<input type="checkbox"/> I want this payment applied to next year's taxes.			
This payment should have been applied to other tax account(s) and/or year(s), escrow (listed below):				
<b>Step 4. Sign the form.</b> Unsigned applications cannot be processed.	By signing below, I hereby apply for the refund of the above-described taxes and certify that the information I have given on this form is true and correct. ( If you make a false statement on this application, you could be found guilty of a Class A misdemeanor or a state jail felony under the Texas Penal Code, Sec. 37.10. )			
	SIGNATURE OF REQUESTOR (REQUIRED)		PRINTED NAME & DATE	
	<i>Veronica Sepulveda</i>		<i>VERONICA Sepulveda 4/18/22</i> ✓	
TAX OFFICE USE ONLY: <input checked="" type="checkbox"/> Approved <input type="checkbox"/> Denied By: <i>NH</i> Date: <i>4-22-22</i> ✓				

THIS DOCUMENT HAS A TRUE WATERMARK AND CAN BE SEEN WHEN HELD TO LIGHT. THIS PAPER IS ALTERATION PROTECTED.

**MILLS ESCROW COMPANY** ✓

TRUST ACCOUNT  
6501 BOEING, STE. H-4  
EL PASO, TX 79925  
(915) 771-8006

CITY BANK  
EL PASO, TX 79913  
16-178 70  
1119

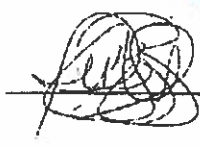
No. ✓ **070707** ✓

CHECK NO
70707

DATE	AMOUNT
1/17/2019	\$26,374.37

-----Twenty Six Thousand Three Hundred Seventy Four and 37/100-----

PAY  
TO THE Tax Assessor Collector  
ORDER OF PO Box 2992  
El Paso, TX 79909-2992



THIS PAPER CONTAINS VISIBLE AND INVISIBLE FIBERS FACE AND BACK WHICH FLUORESCES UNDER ULTRAVIOLET LIGHT.

⑈070707⑈ ⑆⑆⑆⑆30⑆737⑆ 70214272⑈

Account: XXXXXX4272  
Number: 70707

Date: 01-29-2019  
Amount: 26374.37

TAX OFFICE  
RECEIVED  
APR 21 2022

Notes

Go To :

NANCYH  
ACT80122 v1.91

ACCOUNT NO (M0749990001300): Bankruptcy 16-30768 has been closed

05/26/2022 13:27:55  
ACTEP

DEPOSIT Remittance Detail

Summary Query

Summary

Deposit No.	Account No.	Remit Seq No.	Check No.	Payment Amount	Payment Agreement No.					
A01251986	M0749990001300									
Check/Receipt Images	Deposit No.	Receipt Date	Remit Seq No.	Check No.	Payment Type	Payment Amount	Applied Amount	Transaction Type	Account No.	Payer
	EC11012198F	11/02/2021	47934411	CC003895777	EC	\$32,514.15	\$1,064.16	PA	M0749990001300	30039180-MILLS ESCROW
	EC11022098B	11/03/2020	44740139	CC003197484	EC	\$17,509.74	\$1,049.03	PA	M0749990001300	28643589-MILLS ESCROW
	A01132065	01/13/2020	42815117	081485	CH	\$54,037.64	\$1,019.34	AA	M0749990001300	27363816-MILLS ESCROW
	<b>A01251986</b>	<b>01/25/2019</b>	<b>40170775</b>	<b>070707</b>	<b>CH</b>	<b>\$26,374.37</b>	<b>\$825.40</b>	<b>LG</b>	<b>M0749990001300</b>	<b>1512117-MILLS ESCROW</b>
	A01251986	01/25/2019	40170773	070705	CH	\$55,439.77	\$1,012.84	PA	M0749990001300	1512117-MILLS ESCROW
	R030420985	01/25/2019	40170775	070707	CH	\$0.00	\$120.19	LG	M0749990001300	1512117-MILLS ESCROW
	R030420985	01/25/2019	40170775	070707	CH	\$0.00	\$153.06	LG	M0749990001300	1512117-MILLS ESCROW
	R030420985	01/25/2019	40170775	070707	CH	\$0.00	\$323.64	LG	M0749990001300	1512117-MILLS ESCROW
	R030420985	01/25/2019	40170775	070707	CH	\$0.00	\$211.56	LG	M0749990001300	1512117-MILLS ESCROW
	RC220422	01/25/2019	40170775	070707	CH	\$16.95	\$16.95	TR	M0749990001300	1512117-MILLS ESCROW
	RC220422	01/25/2019	40170775	070707	CH	\$16.95	\$16.95	TR	M0749990001300	428-MILLS ESCROW CO.
	A12181775	12/18/2017	36352853	068451	CH	\$40,578.36	\$912.37	AA	M0749990001300	20376420-MILLS ESCROW
<b>Applied Total</b>							<b>\$7,660.92</b>			





# Internal Audit Office

**MAYOR**  
Oscar Leeser

**DATE:** May 11, 2022

**CITY COUNCIL**

**TO:** Maria O. Pasillas, Tax Assessor/Collector

District 1  
Peter Svarzbein

**FROM:** Edmundo S. Calderon, CIA, CGAP, CRMA, Chief Internal Auditor 

**SUBJECT:** Review of Tax Overpayment Refunds that Exceed Three Years

District 2  
Alexandra Anello

The Internal Audit Office conducted a review of the Tax Overpayment Refunds that exceeded a three-year period. This engagement was accepted based on the engagement's potential to improve management of risks, add value, and/or improve the organization's operations (IIA 2010.C1). The work performed does not constitute an engagement conducted in accordance with Generally Accepted Government Auditing Standards (GAS 1.16). The observations and conclusions that are reported in this memorandum do not require Management responses.

District 3  
Cassandra Hernandez

The following Tax Overpayment Refund that exceeded a three-year period was reviewed:

District 4  
Joe Molinar

District 5  
Isabel Salcido

MILLS ESCROW COMPANY	M326-000-0040-1600	\$34.53
MILLS ESCROW COMPANY	M326-000-0020-3400	\$26.35

District 6  
Claudia L. Rodriguez

The Internal Audit Office reviewed the refund applications, copies of cancelled checks or proof of payments. Attached is a list of days from the date the completed applications were received by the Tax Office and sent to the Internal Audit Office for review. The Tax Office is taking 8 days to process the applications received and send for review.

District 7  
Henry Rivera

District 8  
Cissy Lizarraga

Based on our review, the Tax Overpayment Refunds that exceeded a three-year period were determined to be appropriate to send to City Council for approval pursuant to Section 31.11 (c-1) of the Texas Tax Code.

**CITY MANAGER**  
Tommy Gonzalez

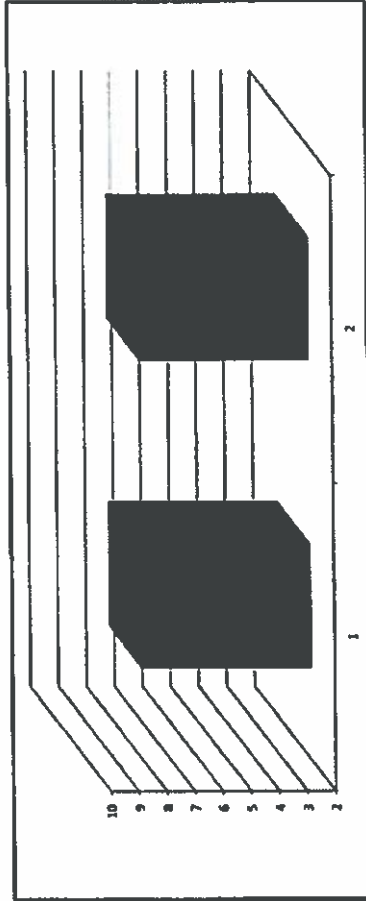
cc: Tomas Gonzalez, City Manager  
Robert Cortinas, Deputy City Manager of Support Services & Chief Financial Officer

**Edmundo S. Calderon – Chief Internal Auditor**  
Internal Audit Office | 218 N. Campbell | El Paso, TX 79901  
O: (915) 212-0069 | Email: calderones@elpasotexas.gov



City of El Paso  
 Internal Audit Office  
 Tax Office Return Project  
 Week of 05/09/2022 Reviews- Over Three Years

P	Refund To	P.I.D. Number	Amount of Refund	Date Application was Received	Date of Proof of Payment was Received in the Tax Office	Date Application was approved by the IRS Office	Date Tax Office Sent to Internal Audit for Review	Taxpayer from Date Proof of Payment to Date Asked to be Reviewed	Date Internal Audit Reviewed Application	Comments
1	MILLS ESCROW COMPANY	MJ26-000-0040-1600	\$ 314.53	4/29/2022	5/2/2022	5/3/2022	5/10/2022	8	5/11/2022	
2	MILLS ESCROW COMPANY	MJ26-000-0020-1400	\$ 26.15	4/29/2022	5/2/2022	5/3/2022	5/10/2022	8	5/11/2022	
			<b>\$60.68</b>							



**RESOLUTION**

**WHEREAS**, pursuant to Section 31.11 (c) of the Texas Code an application for a refund must be made within three (3) years after the date of the payment or the taxpayer waives the right to the refund; and

**WHEREAS**, pursuant to Section 31.11 (c-1) the governing body of the taxing unit may extend the deadline for a single period not to exceed two years on a showing of good cause by the taxpayer; and

**WHEREAS**, taxpayer, Mills Escrow Company through Sanchez Perla & Ruiz Joel ("Taxpayer") has applied for a refund with the tax assessor for their 2018 property taxes that were overpaid on January 31, 2019 in the amount of \$34.53 for all taxing entities; and

**WHEREAS**, City Council may extend the deadline for the Taxpayer's application for the overpayment of the 2018 taxes for a period not to exceed two years on a showing of good cause by the taxpayer; and

**NOW, THEREFORE, BE IT RESOLVED BY THE CITY COUNCIL OF THE CITY OF EL PASO:**

THAT THE City finds that Mills Escrow Company showed a good cause to extend the deadline to apply for a refund of the overpayment of the 2018 taxes and the tax refund in the amount of \$34.53 is approved.

**APPROVED** this \_\_\_\_\_ day of \_\_\_\_\_, 2022.

**CITY OF EL PASO:**

\_\_\_\_\_  
Oscar Leeser  
Mayor

**ATTEST:**

\_\_\_\_\_  
Laura D. Prine  
City Clerk

**APPROVED AS TO FORM:**

*Wendi N. Vineyard*

\_\_\_\_\_  
Wendi N. Vineyard  
Assistant City Attorney

**APPROVED AS TO CONTENT:**

*Maria O. Pasillas*

\_\_\_\_\_  
Maria O. Pasillas, RTA  
Tax Assessor/Collector



TAX OFFICE RECEIVED

MAY 02 2022

MARIA O. PASILLAS, RTA  
CITY OF EL PASO TAX ASSESSOR COLLECTOR  
221 N. KANSAS, STE 300  
EL PASO, TX 79901

PH: (915) 212-0106 FAX: (915) 212-0107 www.elpasotexas.gov/tax-office

SANCHEZ PERLA & RUIZ JOEL  
PO BOX 2603  
FABENS, TX 79838-2603

OP ✓  
+ 3 yrs

Geo No. M326-000-0040-1600	Prop ID 618152
Legal Description of the Property BLK 4 MESA DEL NORTE LOT 16 833 MESA CANYON DR 79838	
OWNER: SANCHEZ PERLA & RUIZ JOEL	
2018 OVERAGE AMOUNT \$34.53	

6. COUNTY OF EL PASO. 7. EL PASO COMMUNITY COLLEGE. 8. UNIVERSITY MEDICAL CENTER OF EL PASO. 11. FABENS ISD. 25. LWR VALLEY WTR DISTRICT. 27. EMERG. SERVICES DIST. #2

Dear Taxpayer:

Our records indicate that an overpayment exists on the property tax account listed above as of the date of this letter. If you paid the taxes on this account and believe you are entitled to a refund, please complete the application below, sign it, and return it to our office. If the taxes were paid by your mortgage/title company or any other party, you must obtain a written letter of release in order for the refund to be issued in your name. If you did not make the payment(s) on this account, please forward this letter to the person who paid these taxes. You may also request the transfer of this overpayment to other tax accounts and/or tax years in the space provided or by attaching an additional sheet if necessary. Your application for refund must be submitted within three years from the date of the overpayment, or you waive the right to the refund (Sec. 31.11c). Governing body approval is required for refunds in excess of \$2500.

APPLICATION FOR PROPERTY TAX REFUND: This application must be completed, signed, and submitted with supporting documentation to be valid.

<b>Step 1. Identify the refund recipient.</b> Show information for whomever will be receiving the refund.	Who should the refund be issued to:			
	Name:		MILLS ESCROW COMPANY	
	Address:		MILLS ESCROW COMPANY	
	City, State, Zip:		PO Box 371805 El Paso, TX 79937-1805 ✓	
<b>Step 2. Provide payment information.</b> Please attach copy of cancelled check, original receipt, online payment confirmation or bank/credit card statement.	Daytime Phone No.:		E-Mail Address:	
	PO Box 371805 El Paso, TX 79937-1805			
	Payment made by:	Check No.	Date Paid	Amount Paid
	Mills Escrow	70782	1/31/19	\$35,307.90
<b>TOTAL AMOUNT PAID (sum of the above amounts)</b>				
<b>Step 3. Provide reason for this refund.</b> Please list any accounts and/or years that you intended to pay with this overage.	Please check one of the following:			
	<input type="checkbox"/> I paid this account in error and I am entitled to the refund.			
	<input checked="" type="checkbox"/> I overpaid this account. Please refund the excess to the address listed in Step 1. ✓			
	<input type="checkbox"/> I want this payment applied to next year's taxes.			
This payment should have been applied to other tax account(s) and/or year(s), escrow (listed below):				
<b>Step 4. Sign the form.</b> Unsigned applications cannot be processed.	By signing below, I hereby apply for the refund of the above-described taxes and certify that the information I have given on this form is true and correct. ( If you make a false statement on this application, you could be found guilty of a Class A misdemeanor or a state jail felony under the Texas Penal Code, Sec. 37.10. )			
	SIGNATURE OF REQUESTOR (REQUIRED)		PRINTED NAME & DATE	
	[Signature]		Veronica Sepulveda 4/22/22 ✓	
TAX OFFICE USE ONLY: <input checked="" type="checkbox"/> Approved <input type="checkbox"/> Denied By: N/A Date: 5-3-22 ✓				

THIS DOCUMENT HAS A TRUE WATERMARK AND CAN BE SEEN WHEN HELD TO LIGHT. THIS PAPER IS ALTERATION PROTECTED.

**MILLS ESCROW COMPANY**  
TRUST ACCOUNT  
6501 BOEING, STE. H-4  
EL PASO, TX 79925  
(915) 774-8006

CITY BANK  
P.O. BOX 7000  
EL PASO, TX 79907  
1113

No. **070782**

CHECK NO.  
70782

DATE	AMOUNT
1/29/2019	\$35,307.90

Thirty Five Thousand Three Hundred Seven and 50/100



PAY TO THE ORDER OF  
Tax Assessor Collector  
PO Box 7000  
El Paso, TX 79907-2692

THIS PAPER CONTAINS 75% RECYCLED AND 100% FIBER FIBERS FACE AND BACK WHICH SUPPLIES ENERGY SAVING, ETC.

⑈070782⑈ ⑆111301737⑆ 70214372⑈

TAX OFFICE  
RECEIVED  
MAY 02 2022

Account: XXXXXX4272  
Number: 70782

Date: 02-11-2019  
Amount: 35307.90



Notes

Go To:

NANCYH  
ACT80122 v1.91

05/26/2022 16:46:17  
ACTEP

DEPOSIT Remittance Detail

Summary Query

Summary

Deposit No.	Account No.	Remit Seq No.	Check No.	Payment Amount	Payment Agreement No.					
X0208192002	M32600000401600									
Check/Receipt Images	Deposit No.	Receipt Date	Remit Seq No.	Check No.	Payment Type	Payment Amount	Applied Amount	Transaction Type	Account No.	Payer
	A01082265	01/08/2022	49040858	001230	CH	\$30,895.77	\$656.52	AA	M32600000401600	29118432-WKS MANAGE
	M202552	01/12/2021	45905640	2950	CH	\$176,827.45	\$669.89	PA	M32600000401600	2552-MESA DEL NORTE L
	A12241981	12/24/2019	42395532	081351	CH	\$27,916.07	\$661.23	PA	M32600000401600	27363816-MILLS ESCROV
	RC220503	01/31/2019	40730846	70782	CH	\$34.53	\$34.53	TR	M32600000401600	2800-MILLS ESCROW CO
	RC220503	01/31/2019	40730846	70782	CH	\$34.53	\$34.53	TR	M32600000401600	SANCHEZ PERLA & RUIZ
	X0208192002	01/31/2019	40730846	70782	CH	\$35,307.90	\$34.53	LG	M32600000401600	SANCHEZ PERLA & RUIZ
	X0208192002	01/31/2019	40730846	70782	CH	\$35,307.90	\$642.69	PA	M32600000401600	SANCHEZ PERLA & RUIZ
	T12041740006	12/06/2017	36192464	02684	CH	\$154,109.32	\$529.94	PA	M32600000401600	24995534-MESA DEL NO
	A12191641	12/19/2016	33396711	2607	CH	\$136,760.74	\$527.48	PA	M32600000401600	24995534-MESA DEL NO
	A12291523	12/29/2015	30514284	1225	CH	\$128,160.76	\$272.70	AA	M32600000401600	MESA DEL NORTE LTD
	A12231441	12/23/2014	27429299	1203	CH	\$77,437.34	\$265.32	PA	M32600000401600	MESA DEL NORTE LTD
	X0127144000	01/27/2014	25319555	01184	CH	\$54,342.32	\$118.01	PA	M32600000401600	MESA DEL NORTE LTD
<b>Applied Total</b>							<b>\$4,605.44</b>			

**RESOLUTION**

**WHEREAS**, pursuant to Section 31.11 (c) of the Texas Code an application for a refund must be made within three (3) years after the date of the payment or the taxpayer waives the right to the refund; and

**WHEREAS**, pursuant to Section 31.11 (c-1) the governing body of the taxing unit may extend the deadline for a single period not to exceed two years on a showing of good cause by the taxpayer; and

**WHEREAS**, taxpayer, Mills Escrow Company through Mills Escrow ("Taxpayer") has applied for a refund with the tax assessor for their 2018 property taxes that were overpaid on January 31, 2019 in the amount of \$26.35 for all taxing entities; and

**WHEREAS**, City Council may extend the deadline for the Taxpayer's application for the overpayment of the 2018 taxes for a period not to exceed two years on a showing of good cause by the taxpayer; and

**NOW, THEREFORE, BE IT RESOLVED BY THE CITY COUNCIL OF THE CITY OF EL PASO:**

THAT THE City finds that Mills Escrow Company through Mills Escrow showed a good cause to extend the deadline to apply for a refund of the overpayment of the 2018 taxes and the tax refund in the amount of \$26.35 is approved.

**APPROVED** this \_\_\_\_\_ day of \_\_\_\_\_, 2022.

**CITY OF EL PASO:**

\_\_\_\_\_  
Oscar Leeser  
Mayor

**ATTEST:**

\_\_\_\_\_  
Laura D. Prine  
City Clerk

**APPROVED AS TO FORM:**

*Wendi N. Vineyard*

\_\_\_\_\_  
Wendi N. Vineyard  
Assistant City Attorney

**APPROVED AS TO CONTENT:**

*Maria O. Pasillas*

\_\_\_\_\_  
Maria O. Pasillas, RTA  
Tax Assessor/Collector

MAY 02 2022



MARIA O. PASILLAS, RTA  
CITY OF EL PASO TAX ASSESSOR COLLECTOR  
221 N. KANSAS, STE 300  
EL PASO, TX 79901

PH: (915) 212-0106 FAX: (915) 212-0107 www.elpasotexas.gov/tax-office

MILLS ESCROW  
906 N MESA, SUITE 101  
EL PASO, TX 79902

OP  
+ 3yrs

Geo No. M326-000-0020-3400	Prop ID 618084
Legal Description of the Property BLK 2 MESA DEL NORTE LOT 34 808 MESA RIM DR 79838	
OWNER: PEREZ REBECCA L	
<b>2018 OVERAGE AMOUNT \$26.35</b>	

6: COUNTY OF EL PASO, 7: EL PASO COMMUNITY COLLEGE, 8: UNIVERSITY MEDICAL CENTER OF EL PASO, 11: TABENS ISD, 25: LWR VALLEY WTR DISTRICT, 27: EMERG. SERVICES DIST, #2

Dear Taxpayer:

Our records indicate that an overpayment exists on the property tax account listed above as of the date of this letter. If you paid the taxes on this account and believe you are entitled to a refund, please complete the application below, sign it, and return it to our office. If the taxes were paid by your mortgage/title company or any other party, you must obtain a written letter of release in order for the refund to be issued in your name. If you did not make the payment(s) on this account, please forward this letter to the person who paid these taxes. You may also request the transfer of this overpayment to other tax accounts and/or tax years in the space provided or by attaching an additional sheet if necessary. Your application for refund must be submitted within three years from the date of the overpayment, or you waive the right to the refund (Sec. 31.11c). Governing body approval is required for refunds in excess of \$2500.

**APPLICATION FOR PROPERTY TAX REFUND:** This application must be completed, signed, and submitted with supporting documentation to be valid

<b>Step 1. Identify the refund recipient.</b> Show information for whomever will be receiving the refund.	Who should the refund be issued to:			
	Name: MILLS ESCROW COMPANY			
	Address: PO Box 371805			
	City, State, Zip: EL Paso, TX 79937-1805		E-Mail Address:	
<b>Step 2. Provide payment information.</b> Please attach copy of cancelled check, original receipt, online payment confirmation or bank/credit card statement.	Payment made by:	Check No.	Date Paid	Amount Paid
	Mills Escrow	CK 20782	1/29/2019	35,307.90
	<b>TOTAL AMOUNT PAID (sum of the above amounts)</b>			
<b>Step 3. Provide reason for this refund.</b> Please list any accounts and/or years that you intended to pay with this overage.	Please check one of the following:			
	<input type="checkbox"/> I paid this account in error and I am entitled to the refund.			
	<input checked="" type="checkbox"/> I overpaid this account. Please refund the excess to the address listed in Step 1.			
	<input type="checkbox"/> I want this payment applied to next year's taxes.			
<b>Step 4. Sign the form.</b> Unsigned applications cannot be processed.	By signing below, I hereby apply for the refund of the above-described taxes and certify that the information I have given on this form is true and correct. ( If you make a false statement on this application, you could be found guilty of a Class A misdemeanor or a state jail felony under the Texas Penal Code, Sec. 37.10. )			
	SIGNATURE OF REQUESTOR (REQUIRED)		PRINTED NAME & DATE	
	[Signature]		Veronica Sepulveda 4/29/22	
TAX OFFICE USE ONLY: <input checked="" type="checkbox"/> Approved <input type="checkbox"/> Denied By: NH Date: 5-3-22				



THIS DOCUMENT HAS A TRUE WATERMARK AND CAN BE SEEN WHEN HELD TO LIGHT. THIS PAPER IS ALTERATION PROTECTED.

**MILLS ESCROW COMPANY**  
TRUST ACCOUNT  
6501 BOEING, STE. H-4  
EL PASO, TX 78925  
(915) 771-8000

CITY BANK  
EL PASO, TX 79912  
18 23 76  
1113

No. **070782**

CHECK NO.  
**70782**

DATE	AMOUNT
1/29/2019	\$35,307.90

—Thirty Five Thousand Three Hundred Seven and 50/100—



PAY TO THE ORDER OF  
Tax Assessor Collector  
PO Box 2907  
El Paso, TX 79929-2907

THIS PAPER CONTAINS ITS OWN INK-DIAPHRAGM PAPER FACE AND BACK WHICH FLUORESCES UNDER ULTRAVIOLET LIGHT.  
⑈070782⑈ ⑆111331737⑆ 70214272⑈

TAX OFFICE  
RECEIVED  
MAY 02 2022

Account: XXXXXX4272  
Number: 70782

Date: 02-11-2019  
Amount: 35307.90

Notes

Go To:

NANCYH  
ACT80122 v1.91

ACCOUNT NO (M32600000203400): Bankruptcy 20-30158 has been closed

05/26/2022 16:49:52  
ACTEP

DEPOSIT Remittance Detail

Summary Query

Summary

Deposit No.	Account No.	Remit Seq No.	Check No.	Payment Amount	Payment Agreement No.					
X0208192002	M32600000203400									
Check/Receipt Images	Deposit No.	Receipt Date	Remit Seq No.	Check No.	Payment Type	Payment Amount	Applied Amount	Transaction Type	Account No.	Payer
	RD3982246	03/30/2022	50138463	0000243728	CH	\$10.20-	\$10.20-	RD	M32600000203400	25959829-TEXSTAR ESC
	A02102201	01/31/2022	50138463	004642	CH	\$2,716.19	\$501.01	AA	M32600000203400	25959829-TEXSTAR ESC
	A02102201	01/31/2022	50138463	004642	CH	\$2,716.19	\$10.20	LG	M32600000203400	25959829-TEXSTAR ESC
	A02102175	02/01/2021	46898135	003068	CH	\$44,947.26	\$511.21	AA	M32600000203400	25959829-TEXSTAR ESC
	A12241981	12/24/2019	42395532	081351	CH	\$27,916.07	\$504.62	PA	M32600000203400	27363816-MILLS ESCROW
	RC220321	01/31/2019	40730846	70782	CH	\$26.35	\$26.35	LG	M32600000203400	28131070-MILLS ESCROW
	RC220321	01/31/2019	40730846	70782	CH	\$26.35-	\$26.35-	TR	M32600000203400	PEREZ REBECCA L
	RC220503	01/31/2019	40730846	70782	CH	\$26.35-	\$26.35-	TR	M32600000203400	28131070-MILLS ESCROW
	RC220503	01/31/2019	40730846	70782	CH	\$26.35	\$26.35	TR	M32600000203400	2800-MILLS ESCROW CO
	X0208192002	01/31/2019	40730846	70782	CH	\$35,307.90	\$490.46	PA	M32600000203400	PEREZ REBECCA L
	X0208192002	01/31/2019	40730846	70782	CH	\$35,307.90	\$26.35	LG	M32600000203400	PEREZ REBECCA L
	T12041740006	12/06/2017	36192464	02684	CH	\$154,109.32	\$210.29	PA	M32600000203400	24995534-MESA DEL NO
Applied Total							\$3,127.19			



El Paso, TX

300 N. Campbell  
El Paso, TX

Legislation Text

---

File #: 22-992, Version: 1

---

**CITY OF EL PASO, TEXAS  
LEGISTAR AGENDA ITEM SUMMARY FORM**

**DISTRICT, DEPARTMENT, CONTACT INFORMATION:**

*Please choose District and Department from drop down menu. Please post exactly as example below.*

*No Title's, No emails. Please use ARIAL 10 Font.*

Members of the City Council, Representative Cassandra Hernandez, (915) 212-0003

**AGENDA LANGUAGE:**

*This is the language that will be posted to the agenda. Please use ARIAL 11 Font.*

For notation pursuant to Section 2.92.080 of the City Code, receipt of campaign contribution by Representative Cassandra Hernandez of \$500 from the El Paso Association of Contractors.



El Paso, TX

300 N. Campbell  
El Paso, TX

Legislation Text

---

**File #: 22-999, Version: 1**

---

**CITY OF EL PASO, TEXAS  
LEGISTAR AGENDA ITEM SUMMARY FORM**

**DISTRICT, DEPARTMENT, CONTACT INFORMATION:**

*Please choose District and Department from drop down menu. Please post exactly as example below.*

*No Title's, No emails. Please use ARIAL 10 Font.*

Members of the City Council, Representative Joe Molinar, (915) 212-0004

**AGENDA LANGUAGE:**

*This is the language that will be posted to the agenda. Please use ARIAL 11 Font.*

For notation pursuant to Section 2.92.080 of the City Code, receipt of campaign contributions by Representative Joe Molinar in the amount of \$500 from the El Paso Chapter Associated General.



El Paso, TX

300 N. Campbell  
El Paso, TX

Legislation Text

---

**File #: 22-1001, Version: 1**

---

**CITY OF EL PASO, TEXAS  
LEGISTAR AGENDA ITEM SUMMARY FORM**

**DISTRICT, DEPARTMENT, CONTACT INFORMATION:**

*Please choose District and Department from drop down menu. Please post exactly as example below.*

*No Title's, No emails. Please use ARIAL 10 Font.*

Members of the City Council, Representative Aleksandra Annello, (915) 212-0002

**AGENDA LANGUAGE:**

*This is the language that will be posted to the agenda. Please use ARIAL 11 Font.*

For notation pursuant to Section 2.92.080 of the City Code, receipt of campaign contributions by City Representative Aleksandra Annello: El Paso Association of Contractors \$500.





---

File #: 22-1002, Version: 1

---

**CITY OF EL PASO, TEXAS  
LEGISTAR AGENDA ITEM SUMMARY FORM**

**DISTRICT, DEPARTMENT, CONTACT INFORMATION:**

*Please choose District and Department from drop down menu. Please post exactly as example below.  
No Title's, No emails. Please use ARIAL 10 Font.*

**District 8**

Members of the City Council, Representative Cissy Lizarraga, (915) 212-0008

**AGENDA LANGUAGE:**

*This is the language that will be posted to the agenda. Please use ARIAL 11 Font.*

Discussion and action that the City Council declares that the expenditure of District 8 discretionary funds in an amount not to exceed \$2,500.00 for the Children's Camp Program at the El Paso Museum of History serves a municipal purpose of enhancing the quality of life through recreational, cultural and educational environments for El Paso residents; and that the City Manager be authorized to effectuate any budget transfer necessary to ensure that the funds are properly expended for such purpose and to execute any related agreements and amendments to such agreements.

**CITY OF EL PASO, TEXAS  
AGENDA ITEM  
AGENDA SUMMARY FORM**

**DEPARTMENT:** Mayor and Council

**AGENDA DATE:** 08/02/2022 (Regular Agenda)

**CONTACT PERSON NAME AND PHONE NUMBER:**

Rep. Cissy Lizarraga, 915-212-0008

**DISTRICT(S) AFFECTED:** District 8

**STRATEGIC GOAL:**

Goal 4 - Enhance El Paso's Quality of Life Through Recreational, Cultural & Educational Environments

**SUBJECT:**

**APPROVE a resolution / ordinance / lease to do what? OR AUTHORIZE the City Manager to do what? Be descriptive of what we want Council to approve. Include \$ amount if applicable.**

That the City Council declares that the expenditure of District 8 discretionary funds in an amount not to exceed \$2,500.00 for the Children's Camp Program at the El Paso Museum of History serves a municipal purpose of enhancing the quality of life through recreational, cultural and educational environments for El Paso residents; and that the City Manager be authorized to effectuate any budget transfer necessary to ensure that the funds are properly expended for such purpose and to execute any related agreements and amendments to such agreements.

**BACKGROUND / DISCUSSION:**

**Discussion of the what, why, where, when, and how to enable Council to have reasonably complete description of the contemplated action. This should include attachment of bid tabulation, or ordinance or resolution if appropriate. What are the benefits to the City of this action? What are the citizen concerns?**

N/A

**PRIOR COUNCIL ACTION:**

**Has the Council previously considered this item or a closely related one?**

N/A

**AMOUNT AND SOURCE OF FUNDING:**

**How will this item be funded? Has the item been budgeted? If so, identify funding source by account numbers and description of account. Does it require a budget transfer?**

District 8 discretionary funds to be transferred to the El Paso Museum of History.

\*\*\*\*\*

---

\*\*\*\*\***REQUIRED AUTHORIZATION**\*\*\*\*\*

**RESOLUTION**

**BE IT RESOLVED BY THE CITY COUNCIL OF THE CITY OF EL PASO:**

That the City Council declares that the expenditure of District 8 discretionary funds in an amount not to exceed \$2,500.00 for the Children's Camp Program at the El Paso Museum of History, serves a municipal purpose of enhancing the quality of life through recreational, cultural and educational environments for El Paso residents.

That the City Manager be authorized to effectuate any budget transfer necessary to ensure that the funds are properly expended for such purpose and to execute any related agreements and amendments to such agreements.

**APPROVED** this \_\_\_\_ day of August, 2022.

**THE CITY OF EL PASO:**

\_\_\_\_\_  
Oscar Leeser, Mayor

**ATTEST:**

\_\_\_\_\_  
Laura D. Prine, City Clerk

**APPROVED AS TO FORM:**

*Danielle Escontrias*  
Danielle Escontrias  
Assistant City Attorney



El Paso, TX

300 N. Campbell  
El Paso, TX

Legislation Text

---

**File #: 22-997, Version: 1**

---

**CITY OF EL PASO, TEXAS  
LEGISTAR AGENDA ITEM SUMMARY FORM**

**DISTRICT, DEPARTMENT, CONTACT INFORMATION:**

*Please choose District and Department from drop down menu. Please post exactly as example below.  
No Title's, No emails. Please use ARIAL 10 Font.*

**All Districts**

Members of the City Council, Representative Aleksandra Annello, (915) 212-0002

**AGENDA LANGUAGE:**

*This is the language that will be posted to the agenda. Please use ARIAL 11 Font.*

Update, discussion, action by City Clerk and City Manager on city staff progress in reviewing and certifying the "Climate Charter" petition submitted by Ground Game Texas.

**CITY OF EL PASO, TEXAS  
AGENDA ITEM  
AGENDA SUMMARY FORM**

**DEPARTMENT:** MAYOR AND COUNCIL

**AGENDA DATE:** August 2, 2022

**CONTACT PERSON NAME AND PHONE NUMBER:**

City Representative Aleksandra Annello, 212-0002

**DISTRICT(S) AFFECTED:** All

**STRATEGIC GOAL:** (Goal 5: Promote Transparent And Consistent Communication Amongst All Members Of The Community)

**SUBJECT:**

**APPROVE a resolution / ordinance / lease to do what? OR AUTHORIZE the City Manager to do what? Be descriptive of what we want Council to approve. Include \$ amount if applicable.**

Update, discussion, action by City Clerk and City Manager on city staff progress in reviewing and certifying the "Climate Charter" petition submitted by Ground Game Texas.

**BACKGROUND / DISCUSSION:**

**Discussion of the what, why, where, when, and how to enable Council to have reasonably complete description of the contemplated action. This should include attachment of bid tabulation, or ordinance or resolution if appropriate. What are the benefits to the City of this action? What are the citizen concerns?**

On July 25<sup>th</sup> a Citizen petition was turned in to the City Clerk with approximately 39,000 signatures.

**PRIOR COUNCIL ACTION:**

Has the Council previously considered this item or a closely related one?

N/A

**AMOUNT AND SOURCE OF FUNDING:**

**How will this item be funded? Has the item been budgeted? If so, identify funding source by account numbers and description of account. Does it require a budget transfer?**

N/A

---

\*\*\*\*\*REQUIRED AUTHORIZATION\*\*\*\*\*



---

File #: 22-996, Version: 1

---

**CITY OF EL PASO, TEXAS  
LEGISTAR AGENDA ITEM SUMMARY FORM**

**DISTRICT, DEPARTMENT, CONTACT INFORMATION:**

*Please choose District and Department from drop down menu. Please post exactly as example below.  
No Title's, No emails. Please use ARIAL 10 Font.*

**All Districts**

Members of the City Council, Representative Aleksandra Annello, (915) 212-0002

**AGENDA LANGUAGE:**

*This is the language that will be posted to the agenda. Please use ARIAL 11 Font.*

Discussion and action on City readiness to consider an ordinance on August 16, 2022, to place the Climate Charter initiative on the November 8, 2022, general election ballot, in the event that the petition is certified by the City Clerk.

**CITY OF EL PASO, TEXAS  
AGENDA ITEM  
AGENDA SUMMARY FORM**

**DEPARTMENT:** MAYOR AND COUNCIL

**AGENDA DATE:** August 2, 2022

**CONTACT PERSON NAME AND PHONE NUMBER:**

City Representative Aleksandra Annello, 212-0002

**DISTRICT(S) AFFECTED:** All

**STRATEGIC GOAL:** (Goal 5: Promote Transparent And Consistent Communication Amongst All Members Of The Community)

**SUBJECT:**

**APPROVE a resolution / ordinance / lease to do what? OR AUTHORIZE the City Manager to do what? Be descriptive of what we want Council to approve. Include \$ amount if applicable.**

Discussion and action on City readiness to consider an ordinance on August 16, 2022, to place the Climate Charter initiative on the November 8, 2022, general election ballot, in the event that the petition is certified by the City Clerk.

**BACKGROUND / DISCUSSION:**

**Discussion of the what, why, where, when, and how to enable Council to have reasonably complete description of the contemplated action. This should include attachment of bid tabulation, or ordinance or resolution if appropriate. What are the benefits to the City of this action? What are the citizen concerns?**

On July 25<sup>th</sup> a Citizen petition was turned in to the City Clerk with approximately 39,000 signatures.

**PRIOR COUNCIL ACTION:**

Has the Council previously considered this item or a closely related one?

N/A

**AMOUNT AND SOURCE OF FUNDING:**

**How will this item be funded? Has the item been budgeted? If so, identify funding source by account numbers and description of account. Does it require a budget transfer?**

N/A

---

\*\*\*\*\*REQUIRED AUTHORIZATION\*\*\*\*\*



El Paso, TX

300 N. Campbell  
El Paso, TX

Legislation Text

---

**File #: 22-970, Version: 1**

---

**CITY OF EL PASO, TEXAS  
LEGISTAR AGENDA ITEM SUMMARY FORM**

**DISTRICT, DEPARTMENT, CONTACT INFORMATION:**

*Please choose District and Department from drop down menu. Please post exactly as example below.  
No Title's, No emails. Please use ARIAL 10 Font.*

**All Districts**

Capital Improvement Department, Yvette Hernandez, (915) 212-1860

**AGENDA LANGUAGE:**

*This is the language that will be posted to the agenda. Please use ARIAL 11 Font.*

Update from the El Paso County's Planning and Development Department and Camino Real Regional Mobility Authority regarding the Pellicano Widening Project (TxDOT CSJ 0924-06-534).



**CITY OF EL PASO, TEXAS  
AGENDA ITEM  
DEPARTMENT HEAD'S SUMMARY FORM**

**AGENDA DATE:** August 2, 2022  
**PUBLIC HEARING DATE:** N/A  
**CONTACT PERSON(S) NAME AND PHONE NUMBER:** Yvette Hernandez, City Engineer, (915) 212-1860  
**DISTRICT(S) AFFECTED:** All Districts – County update  
**STRATEGIC GOAL:** N/A  
**SUBGOAL:** N/A

**SUBJECT:**

Receive an update from the El Paso County's Planning & Development Department and Camino Real Regional Mobility Authority regarding the Pellicano Widening Project (TxDOT CSJ 0924-06-534).

**BACKGROUND / DISCUSSION:**

The widening and reconstruction of Pellicano Drive is an initiative that began in 2006 as the County began to work with cooperative property owners in the area to acquire the necessary right-of-way for the expansion and reconstruction.

The project is identified in the El Paso Metropolitan Planning Organization's planning documents as a project scheduled to be let for construction in 2019. Limits of the project extend from Loop 375 to Darrington Rd. for approximately 3 miles in length. Improvements include, six-lanes divided, raised median, illumination, landscaping, pavement, curb and gutter and sidewalks/bike lanes.

**PRIOR COUNCIL ACTION:**

N/A

**AMOUNT AND SOURCE OF FUNDING:**

N/A

**HAVE ALL AFFECTED DEPARTMENTS BEEN NOTIFIED?** \_\_\_ YES \_\_\_ NO

**PRIMARY DEPARTMENT:** Capital Improvement Department

**SECONDARY DEPARTMENT:**

---

\*\*\*\*\*REQUIRED AUTHORIZATION\*\*\*\*\*

**DEPARTMENT HEAD:**



(If Department Head Summary Form is initiated by Purchasing, client department should sign also)



Legislation Text

---

File #: 22-995, Version: 1

---

**CITY OF EL PASO, TEXAS  
LEGISTAR AGENDA ITEM SUMMARY FORM**

**DISTRICT, DEPARTMENT, CONTACT INFORMATION:**

*Please choose District and Department from drop down menu. Please post exactly as example below.  
No Title's, No emails. Please use ARIAL 10 Font.*

**All Districts**

Communications and Public Affairs, Laura Cruz-Acosta, (915) 212-1061

**AGENDA LANGUAGE:**

*This is the language that will be posted to the agenda. Please use ARIAL 11 Font.*

An Ordinance of the City Council of the City of El Paso, Texas, ordering a Special Election for the submission of Charter Amendments to Section 2.2C to allow persons to serve two full terms as Mayor or District Representative if such person carried out an unexpired term; Section 3.18 to allow City Council to authorize leases for 40 years or less by Resolution or Ordinance; Section 3.5A to allow Council to reschedule meetings for holidays and allow the Mayor to cancel a Council meeting if required due to Declared Emergency; Section 3.9B, 3.10B, and 6.1-12 to align to State law and update obsolete references; Section 3.11 to remove the requirement for a second petition in initiatives, and provide a procedure for citizens to initiate City Ordinances; Section 1.2, 3.5E, 3.6, 4.1B, 4.3 and 7.3 to authorize the Mayor to vote on all Council items, removing the tie-breaking and veto capacity; Section 6.1-4 to authorize the City to create a policy regarding membership on the Civil Service Commission to reflect the community and City Workforce; Sections 6.2-2 and 6.2-3 to align the employee serving as Civil Service Commission Recorder with other employees carrying out similar duties; Section 6.7-1 and 6.8-1 to allow the City to establish more flexible policies in hiring employees; Section 6.13-11D to establish the City contribution to the Police and Fire Pension Fund of no less than 18% of the wages of the participants, and remove the limit on the City's contribution; such Election to be held within the City, on November 8, 2022; making provisions for the conduct of the Election; and authorizing a contract with El Paso County to furnish election services and equipment; providing for severability and setting an effective date.

**CITY OF EL PASO, TEXAS  
AGENDA ITEM  
DEPARTMENT HEAD'S SUMMARY FORM**

**DEPARTMENT:** Communications and Public Affairs

**AGENDA DATE:** August 2, 2022

**PUBLIC HEARING DATE:** August 16, 2022

**CONTACT PERSON NAME AND PHONE NUMBER:** Laura Cruz-Acosta, (915) 212-1061

**DISTRICT(S) AFFECTED:** All Districts

**STRATEGIC GOAL:** Goal 6 – Set the Standard for Sound Governance and Fiscal Management

**SUBGOAL:** 6.8 – Support Transparent and Inclusive Government

**SUBJECT:**

AN ORDINANCE OF THE CITY COUNCIL OF THE CITY OF EL PASO, TEXAS, ORDERING A SPECIAL ELECTION FOR THE SUBMISSION OF CHARTER AMENDMENTS TO SECTION 2.2C TO ALLOW PERSONS TO SERVE TWO FULL TERMS AS MAYOR OR DISTRICT REPRESENTATIVE IF SUCH PERSON CARRIED OUT AN UNEXPIRED TERM; SECTION 3.18 TO ALLOW CITY COUNCIL TO AUTHORIZE LEASES FOR 40 YEARS OR LESS BY RESOLUTION OR ORDINANCE; SECTION 3.5A TO ALLOW COUNCIL TO RESCHEDULE MEETINGS FOR HOLIDAYS AND ALLOW THE MAYOR TO CANCEL A COUNCIL MEETING IF REQUIRED DUE TO DECLARED EMERGENCY; SECTION 3.9B, 3.10B, AND 6.1-12 TO ALIGN TO STATE LAW AND UPDATE OBSOLETE REFERENCES; SECTION 3.11 TO REMOVE THE REQUIREMENT FOR A SECOND PETITION IN INITIATIVES, AND PROVIDE A PROCEDURE FOR CITIZENS TO INITIATE CITY ORDINANCES; SECTION 1.2, 3.5E, 3.6, 4.1B, 4.3 AND 7.3 TO AUTHORIZE THE MAYOR TO VOTE ON ALL COUNCIL ITEMS, REMOVING THE TIE-BREAKING AND VETO CAPACITY; SECTION 6.1-4 TO AUTHORIZE THE CITY TO CREATE A POLICY REGARDING MEMBERSHIP ON THE CIVIL SERVICE COMMISSION TO REFLECT THE COMMUNITY AND CITY WORKFORCE; SECTIONS 6.2-2 AND 6.2-3 TO ALIGN THE EMPLOYEE SERVING AS CIVIL SERVICE COMMISSION RECORDER WITH OTHER EMPLOYEES CARRYING OUT SIMILAR DUTIES; SECTION 6.7-1 AND 6.8-1 TO ALLOW THE CITY TO ESTABLISH MORE FLEXIBLE POLICIES IN HIRING EMPLOYEES; SECTION 6.13-11D TO ESTABLISH THE CITY CONTRIBUTION TO THE POLICE AND FIRE PENSION FUND OF NO LESS THAN 18% OF THE WAGES OF THE PARTICIPANTS, AND REMOVE THE LIMIT ON THE CITY'S CONTRIBUTION; SUCH ELECTION TO BE HELD WITHIN THE CITY, ON NOVEMBER 8, 2022; MAKING PROVISIONS FOR THE CONDUCT OF THE ELECTION; AND AUTHORIZING A CONTRACT WITH EL PASO COUNTY TO FURNISH ELECTION SERVICES AND EQUIPMENT; PROVIDING FOR SEVERABILITY AND SETTING AN EFFECTIVE DATE.

**BACKGROUND / DISCUSSION:**

On January 18, 2022 City Council approved a Resolution creating the Ad Hoc Charter Advisory Committee with the purpose of reviewing proposed Charter amendments by a majority vote of City Council. The Committee's final recommendations were presented on July 18, 2022. City Council is moving forward with changes to sections as listed in ordinance.

**PRIOR COUNCIL ACTION:**

Last Ordinance approving a Special Election for this purpose was approved on July 10, 2018.

**AMOUNT AND SOURCE OF FUNDING:**

111-1000-11020-522030 Election Contracts

---

\*\*\*\*\*REQUIRED AUTHORIZATION\*\*\*\*\*

**DEPARTMENT HEAD:** *Laura Cruz-Acosta*

---

ORDINANCE NO. \_\_\_\_\_

**AN ORDINANCE OF THE CITY COUNCIL OF THE CITY OF EL PASO, TEXAS, ORDERING A SPECIAL ELECTION FOR THE SUBMISSION OF CHARTER AMENDMENTS TO SECTION 2.2C TO ALLOW PERSONS TO SERVE TWO FULL TERMS AS MAYOR OR DISTRICT REPRESENTATIVE IF SUCH PERSON CARRIED OUT AN UNEXPIRED TERM; SECTION 3.18 TO ALLOW CITY COUNCIL TO AUTHORIZE LEASES FOR 40 YEARS OR LESS BY RESOLUTION OR ORDINANCE; SECTION 3.5A TO ALLOW COUNCIL TO RESCHEDULE MEETINGS FOR HOLIDAYS AND ALLOW THE MAYOR TO CANCEL A COUNCIL MEETING IF REQUIRED DUE TO DECLARED EMERGENCY; SECTION 3.9B, 3.10B, AND 6.1-12 TO ALIGN TO STATE LAW AND UPDATE OBSOLETE REFERENCES; SECTION 3.11 TO REMOVE THE REQUIREMENT FOR A SECOND PETITION IN INITIATIVES, AND PROVIDE A PROCEDURE FOR CITIZENS TO INITIATE CITY ORDINANCES; SECTION 1.2, 3.5E, 3.6, 4.1B, 4.3 AND 7.3 TO AUTHORIZE THE MAYOR TO VOTE ON ALL COUNCIL ITEMS, REMOVING THE TIE-BREAKING AND VETO CAPACITY; SECTION 6.1-4 TO AUTHORIZE THE CITY TO CREATE A POLICY REGARDING MEMBERSHIP ON THE CIVIL SERVICE COMMISSION TO REFLECT THE COMMUNITY AND CITY WORKFORCE; SECTIONS 6.2-2 AND 6.2-3 TO ALIGN THE EMPLOYEE SERVING AS CIVIL SERVICE COMMISSION RECORDER WITH OTHER EMPLOYEES CARRYING OUT SIMILAR DUTIES; SECTION 6.7-1 AND 6.8-1 TO ALLOW THE CITY TO ESTABLISH MORE FLEXIBLE POLICIES IN HIRING EMPLOYEES; SECTION 6.13-11D TO ESTABLISH THE CITY CONTRIBUTION TO THE POLICE AND FIRE PENSION FUND OF NO LESS THAN 18% OF THE WAGES OF THE PARTICIPANTS, AND REMOVE THE LIMIT ON THE CITY'S CONTRIBUTION; SUCH ELECTION TO BE HELD WITHIN THE CITY, ON NOVEMBER 8, 2022; MAKING PROVISIONS FOR THE CONDUCT OF THE ELECTION; AND AUTHORIZING A CONTRACT WITH EL PASO COUNTY TO FURNISH ELECTION SERVICES AND EQUIPMENT; PROVIDING FOR SEVERABILITY AND SETTING AN EFFECTIVE DATE.**

**WHEREAS,** the City Council appointed a nine (9) member Ad Hoc Charter Advisory Committee in January 2022 to assist in the review and to make recommendations on potential charter amendments; and

**WHEREAS,** the Ad Hoc Charter Advisory Committee reviewed proposed Charter Amendments approved by a majority of the City Council and the Committee met from February 2022 through May 2022 to review the City Charter and in May 2022, the Committee finalized its report of its findings in writing, and presented its proposed amendments to the City Council; and

**WHEREAS,** the City Council has reviewed the proposed Amendments by the Committee and the City Council of the City of El Paso, Texas has determined it appropriate to

submit a proposed amendment to the existing City Charter of the City of El Paso to the qualified voters of the City for their adoption or rejection thereof pursuant to Section 9.004(a) of the Texas Local Government Code; and

**WHEREAS**, Section 9.04(b) of the Texas Local Government Code requires that an ordinance be approved ordering said election to be held on the first authorized uniform election date prescribed by the Texas Election Code and establishing the procedure to be followed in said election; and

**WHEREAS**, Section 41.001 of the Texas Election Code establishes November 8, 2022, as a uniform election date for the purposes of conducting an election; and

**WHEREAS**, pursuant to Texas Local Government Code Section 9.004(e), more than one amendment may be combined in one ballot proposition as long as the amendments contain only one subject; and

**WHEREAS**, pursuant to the Texas Local Government Code Section 9.004 a ballot for proposed charter amendments shall be prepared so that a voter may approve or disapprove any one or more amendments without having to approve or disapprove all of the amendments; and

**WHEREAS**, during a public meeting held on August 2, 2022, the City Council considered and approved for public vote, in the form of a ballot proposition, the following Charter amendments after considering recommendations by the 2022 Ad Hoc Charter Advisory Committee; and

**WHEREAS**, the City Council of the City of El Paso, Texas, hereby directs City staff to publish notice of the special charter election in a newspaper of general circulation in the City on the same day in each of two (2) successive weeks, the date of the first publication to be not less than fourteen (14) days prior to the date of the November 8, 2022 election, in compliance with Section 9.004(c) of the Texas Local Government Code.

**NOW, THEREFORE, BE IT ORDAINED BY THE CITY COUNCIL OF THE CITY OF EL PASO, TEXAS:**

**SECTION 1 – CHARTER AMENDMENT ELECTION CALLED**

The El Paso City Council does hereby order an election to submit to the voters of the City of El Paso proposed amendments to the City Charter, to be held on Tuesday, November 8, 2022. That such election shall be held at the precincts and the polling places designated in Exhibit "A" or such other locations as may be designated prior to the election by the City Council, attached hereto and made a part hereof for all purposes, and said polling places shall open at 7 a.m. and remain open until 7 p.m. on the day of the election.

That at such election, the following amendments to the Charter of the City of El Paso ("Propositions") shall be submitted to the qualified voters of the City and official ballots for the election shall be prepared in accordance with the Texas Election Code so as to permit the

electors to vote for or against the proposed amendment, and with such proposition to be expressed substantially as follows:

**CITY OF EL PASO PROPOSITION A**

**Text of Amendment**

Amending Section 2.2C of the City Charter, relating to term limits for the Mayor and District Representatives, to read in pertinent part as follows:

**Section 2.2C LIMITATION.**

No Mayor or Representative may hold such office for more than a total of ten years throughout their lifetime, however, a person who serves an unexpired term due to a Mayor or Representative’s resignation will be allowed to serve two full four-year terms, regardless of whether it results in more than a total of ten years.

**City of El Paso Special Election for Charter Amendment  
Ballot Proposition A**

Should section 2.2C of the City Charter, relating to term limits, be amended to provide that a person who serves an unexpired term due to a Mayor or Representative’s vacancy be allowed to serve two full four-year terms, regardless of whether it results in more than a total of ten years served throughout their lifetime?

YES ( )

NO ( )

**CITY OF EL PASO PROPOSITION B**

**Text of Amendment**

Amending Section 3.1 of the City Charter, relating to the creation; composition; powers and duties of City Council, to read in pertinent part as follows:

**Section 3.1 – CREATION; COMPOSITION; POWERS AND DUTIES**

There shall be a City Council consisting of District Representatives and the Mayor. The Council shall have legislative powers, and the power and duty to select, direct, and regularly evaluate the City Manager, as well as such other and specific powers and duties as may be provided by law or this Charter. Each Representative shall have the discretion and sole authority to appoint and remove district office staff.

**City of El Paso Special Election for Charter Amendment**  
**Ballot Proposition B**

Should section 3.1 of the City Charter, relating to creation, composition; powers and duties of Council be amended to allow City Council Representatives to appoint and remove district office staff?

YES ( )

NO ( )

**CITY OF EL PASO PROPOSITION C**

**Text of Amendment**

Amending Section 3.18 of the City Charter, relating to the use of ordinances, to read in pertinent part as follows:

**Section 3.18 LEASE; FRANCHISE, AND CONVEYANCE.**

The right of control, ownership and use of streets, alleys, parks and public places of the City is declared to be inalienable except as provided by ordinance passed by the Council and except for uses of less than thirty days which may have a separate approval process as established by ordinance.

Any authorization for the conveyance, lease, or grant of a franchise regarding the property of the City shall provide for payment to the City of a reasonable fee as consideration for that conveyance, lease, or franchise.

Any sale of City owned property in fee simple, franchise or lease for an initial term longer than forty years shall be approved by ordinance.

In addition, any authorization for a lease or franchise must provide that the City may revoke it if necessary to secure efficiency of public service at a reasonable rate, and must assure that the property is maintained in good condition throughout the life of the lease or franchise.

**City of El Paso Special Election for Charter Amendment**  
**Ballot Proposition C**

Should section 3.18 of the City Charter relating to Leases, Franchises, and Conveyances be amended to authorize Council to lease City owned property for 40 years or less by Council resolution or ordinance?

YES ( )

NO ( )

**CITY OF EL PASO PROPOSITION D**

**Text of Amendment**

Amending Section 3.5 of the City Charter, relating to City Council Procedures and Rules, to read in pertinent part as follows:

**Section 3.5 A CITY COUNCIL PROCEDURES AND RULES**

Meetings. Regular meetings of the Council shall be held in Council chambers no less than once every other week at such times as may be prescribed by resolution, except that Council may reschedule meetings by resolution to allow for City holidays, but must have no less than two regular meetings per month. The Mayor may cancel a meeting if necessary due to a Federal, State or Local declared emergency.

**City of El Paso Special Election for Charter Amendment**  
**Ballot Proposition D**

Should section 3.5A of the City Charter be amended to allow Council to reschedule meetings by resolution to allow for City holidays but shall hold no less than two regular meetings per month?

YES ( )

NO ( )

**CITY OF EL PASO PROPOSITION E**

**Text of Amendment**

**Section 3.5 A CITY COUNCIL PROCEDURES AND RULES**

Meetings. Regular meetings of the Council shall be held in Council chambers no less than once every other week at such times as may be prescribed by resolution, except that Council may reschedule meetings by resolution to allow for City holidays, but must have no less than two regular meetings per month. The Mayor may cancel a meeting if necessary due to a Federal, State or Local declared emergency.

**City of El Paso Special Election for Charter Amendment**  
**Ballot Proposition E**

Should section 3.5A of the City Charter be amended to allow the Mayor to cancel a meeting if necessary due to a Federal, State or Local declared emergency?

YES ( )

NO ( )



**CITY OF EL PASO PROPOSITION F**

**Text of Amendment**

Amending Sections 3.9B relating to Ordinances, 3.10B relating to emergency ordinances, 6.1-12 relating to civil service hearing officers to read in pertinent part as follows:

**Section 3.9 ORDINANCES IN GENERAL.**

B. Legislative Procedure. Except as provided in Section 3.13, an ordinance may be introduced by any Council member at any meeting of the Council. A proposed ordinance must be filed with the City Clerk in sufficient time for inclusion on the agenda for the Council meeting at which it is to be introduced. Upon such filing the City Clerk shall distribute copies to each member of the Council and to the City Manager. No ordinance shall be adopted finally except at a regular open meeting of the Council following notice, publication, and a public hearing. The notice shall contain:

- 1.The proposed ordinance or a brief summary thereof;
- 2.The places where copies of it have been filed and the times when they are available for public examination; and
- 3.The time and place for the public hearing. The notice shall be published by any contemporary means of information sharing, including but not limited to publication in a newspaper of general circulation in the City or placement on a website at least five days prior to the public hearing. The hearing may be held by a designated Council committee or the Council separately or in connection with any Council meeting and may be adjourned to a specified time. All interested persons present shall have an opportunity to be heard. As soon as practicable after adoption of any ordinance, the City Clerk shall publish it again, with notice of its adoption, in abstract form, by any contemporary means of information sharing. These abstracts must state, at a minimum, the purpose of the ordinance and, where penal, the penalty provided. In any event, the publication must be written so as to be understood by an average person.

**Section 3.10B EMERGENCY ORDINANCES.**

Procedures. An emergency ordinance shall be introduced in the form and manner prescribed for ordinances generally, except that it may be introduced on one-hour public notice, and shall contain, after the enacting clause, a declaration stating that an emergency exists and describing the emergency in clear and specific terms. An emergency ordinance may be adopted with or without amendment or rejected at the meeting at which it is introduced, but the unanimous vote of the Council members present shall be required for adoption.

**Section 6.1-12 HEARING OFFICERS.**

The Commission will appoint one or more compensated hearing officers to hear appeals made under Section 6.13-4. The need for hearing officers in excess of one shall be determined jointly by the Commission and the City Manager. Hearing officers will perform those duties and functions necessary to render a recommendation to the Commission on the matter in dispute.

The hearing officers will serve at the Commission’s pleasure, and will be procured through the City's procurement process.

**City of El Paso Special Election for Charter Amendment**  
**Ballot Proposition F**

Shall Sections 3.9B, 3.10B, 6.1-12of the City Charter be amended to eliminate provisions which have become inoperative because they have been superseded by state law; replace obsolete references and update terminology to current legal usage?

YES ( )

NO ( )

**CITY OF EL PASO PROPOSITION G**

**Text of Amendment**

Amending Section 3.11 of the City Charter, relating to Initiatives to read in pertinent part as follows:

**Section 3.11 INITIATIVE.**

Any five registered voters, referred to in this section as the committee, may initiate an ordinance that complies with federal, state and local law by filing with the City Clerk a statement that they intend to circulate a petition, however no ordinance may be initiated through this process regarding appropriation or allocation of City funds, zoning or rezoning, levy of taxes, setting utility rates, purchase or sale of an interest in real property or granting a franchise. Such statement must include the names and addresses of the committee members, the full text of the proposed ordinance, and the designated lead committee member.

The City Clerk shall place the proposed Ordinance on the City Council Agenda for introduction within thirty days after receiving the statement, followed by a public hearing at the second reading. If City Council fails to adopt the ordinance, or adopts it with amendments, the City Clerk will notify the committee through the lead committee member.

If the committee still wishes to seek adoption of the ordinance after Council fails to adopt, or does not agree to Council’s amendments, it will then have 180 calendar days after notice from the City Clerk to complete the petition by gathering signatures in the form required by state law,

including but not limited to printed name, residence address and date of birth or voter registration of a number of registered voters equal to at least five percent of the voters who voted in the last general City election. The petition must set forth the precise content of the ordinance desired by the petitioners.

Within thirty working days, the City Clerk shall review the petition to verify if it meets all requirements, and if authenticated with the required number of signatures, must place that ordinance on the agenda of a Council meeting to be held within thirty working days of the authentication by the City Clerk, of the petition bearing the authenticated names and addresses of the petitioners. Such an item shall be treated by the Council exactly as any other proposed ordinance.

If Council does not adopt, or adopts the proposed ordinance in an amended form, the City Clerk thereafter must place the proposed ordinance on the ballot at the next citywide general election specified in State law, if the proposal receives the favorable vote of a majority of those voting in that election it shall thereupon become a City ordinance.

The Council is not obliged to consider the same ordinance initiated by petition, or one that is substantially the same, more often than once in: two years.

**City of El Paso Special Election for Charter Amendment**  
**Ballot Proposition G**

Should section 3.11 relating to the initiative petition of the City Charter be amended to remove the requirement for a second petition, and institute a process for the public to initiate a City ordinance?

YES ( )

NO ( )

**CITY OF EL PASO PROPOSITION H**

**Text of Amendment**

Amending Section 1.2 relating to Definitions, 3.5E relating to City Council Procedures and Rules, 3.6 relating to Legislative Committees, 4.1B Power of the Mayor, 4.3 relating to Mayor Pro Tempore and 7.3 relating to budget procedures of the City Charter effective the first City Council meeting January of 2025, to read in pertinent part as follows:

**Section 1.2 - DEFINITIONS**

As used in this Charter, the term "laws of Texas" shall include the Constitution and statutes of the State of Texas, the common law as it exists in the State of Texas, and appropriate case law. As used herein, "State" shall mean the State of Texas; "City" shall mean the City of El Paso; "City Council" or "Council" shall mean the Mayor and Representatives of the City of El Paso, with the Mayor being a voting member of Council; and "department" shall mean any City agency, office, bureau or other organizational unit.

### **Section 3.5 E CITY COUNCIL PROCEDURES AND RULES**

Effective Date. Ordinances and resolutions finally adopted by the Council shall be filed in the office of the City Clerk and signed by the Mayor before they take effect. If the Mayor shall either fail to sign any adopted ordinance or resolution within five days after it has been filed with the City Clerk, exclusive of the day of filing, it shall become law.

### **Section 3.6 LEGISLATIVE COMMITTEES**

A. The members of Council may resolve themselves into committees, both standing and special, when this is convenient for the conduct of legislative business, including the investigative powers described in Section 3.8. Rules governing the organization and procedures of these committees shall be made by the Council.

### **Section 4.1B POWERS OF THE MAYOR**

The Mayor shall be a voting member of City Council and preside over the City Council meetings, having the power to propose legislation; represent the City in intragovernmental and intergovernmental relationships; appoint with the consent of the Council the members of citizen advisory boards and commissions; make appointments and perform duties pursuant to federal and state law; present an annual state of the City message, convene the Council in special session and perform other duties specified by the Council.

### **Section 4.3 – MAYOR PRO TEMPORE**

A. At the first meeting upon the start of new terms of office following each general election, the Council shall elect from among the Representatives a Mayor Pro Tempore, who shall hold that office for a two year term. Should the office of Mayor Pro Tempore become vacant, the Council shall elect a new Mayor Pro Tempore.

B. During the absence or disability of the Mayor, the Mayor Pro Tempore shall act as Mayor.

### **Section 7.3 – BUDGET PROCEDURES**

The procedures here stated shall govern adoption of the annual budget and the appropriations of monies pursuant thereto.

D. Adoption. The budget shall be adopted by resolution, not later than the day before the first day of the City's fiscal and budget year; but, in the event the budget is not adopted, the appropriation for personnel and essential operating supplies made in the previous year shall be extended until the new budget is adopted.

**City of El Paso Special Election for Charter Amendment**  
**Ballot Proposition H**

Should section 1.2, 3.5E , 3.6, 4.1B, 4.3,and 7.3 of the City Charter be amended to authorize the Mayor to vote on all City Council agenda items and remove the Mayor’s tie-breaking and veto capacity effective the first City Council meeting of January 2025?

YES ( )

NO ( )

**CITY OF EL PASO PROPOSITION I**

**Text of Amendment**

Amending Section 6.1-4 of the City Charter, relating to Civil Service qualifications to read in pertinent part as follows:

**Section 6.1-4 QUALIFICATIONS.**

Members of the Commission must be residents of the City at the time of their appointment and remain a resident of the City throughout their term of office. No Commissioner shall be related in any manner described in Article III, Section 3.3 B to any employee of the City, the Public Service Board, or any entity that has a contract with the City to operate or manage any City facility or department, nor hold any salaried public office or other employment compensated by the City, and any violation of this provision shall be deemed malfeasance in office and cause for removal therefrom. The City should adopt rules that reflect the diversity of the community and City workforce. No more than three Commissioners may be former city employees, and any such Commissioners are not eligible for appointment until two years following separation from the City. Any commissioner may be either actively employed or retired.

**City of El Paso Special Election for Charter Amendment**  
**Ballot Proposition I**

Should 6.1-4 of the City Charter be amended to allow for appointment of Civil Service Commissioners that reflect the diversity of the community and City workforce?

YES ( )

NO ( )

## **CITY OF EL PASO PROPOSITION J**

### **Text of Amendment**

Amending Section 6.2-2 of the City Charter, relating to the unclassified services and 6.2-3B, relating to appointment and removal of unclassified personnel to read in pertinent part as follows:

#### **Section 6.2-2 UNCLASSIFIED SERVICES.**

The unclassified services shall include only the following positions:

- A. The City Attorney, Assistant City Attorneys, law clerks and paralegal personnel;
- B. The Mayor's executive secretary(s) and Executive Assistant(s);
- C. All elected officials;
- D. Members of all City boards, commissions, and committees who serve without compensation;
- E. Employees hired by contract, and short-term or limited-funding grant-funded employees as designated by the City Manager and hired on or after the effective date of this amendment;
- F. The City Manager;
- G. All executive level employees, and executive staff or salaried professional employees reporting directly to the City Manager;
- H. Employees hired on or after May 18, 2007 who work at the Metropolitan Planning Organization; and
- I. Persons given provisional and temporary appointments who are not classified employees at the time of such appointment.
- J. A person hired solely as a District Representative's legislative aide for the limited period of the term of office for that District Representative.

#### **Section 6.2-3 – APPOINTMENT AND REMOVAL OF UNCLASSIFIED PERSONNEL**

- B. Except as otherwise provided by law or in this Charter, unclassified personnel may be removed by the City Manager or designee, who may establish written procedures for removal.

**City of El Paso Special Election for Charter Amendment**  
**Ballot Proposition J**

Should Section 6.2-2 relating to Unclassified Services and 6.2-3 relating to appointment and removal of unclassified personnel be amended to align the person carrying out the role of civil service commission recorder with all other unclassified City employees who may be removed by the City Manager or designee in accordance with the City Charter?

YES ( )

NO ( )

**CITY OF EL PASO PROPOSITION K**

**Text of Amendment**

Amending Section 6.7-1 and 6.8-1 of the City Charter, relating to penalty for deceit in examinations, examinations and eligibility to read in pertinent part as follows:

**Section 6.7-1 PENALTY FOR DECEIT IN EXAMINATION.**

(Reserved.)

**Section 6.8-1 EXAMINATION AND ELIGIBILITY**

The Human Resources Director shall establish administrative policies and procedures for the promotion process, and eligibility, consistent with the provisions of this Article and all applicable federal and state employment laws.

**City of El Paso Special Election for Charter Amendment**  
**Ballot Proposition K**

Should Section 6.7-1 be deleted and 6.8-1 relating to Examinations of the City Charter be amended to allow the City to establish Civil Service Rules, policies and procedures for the promotion of City employees?

YES ( )

NO ( )

CITY OF EL PASO PROPOSITION L

**Text of Amendment**

Amending Section 6.13-11D of the City Charter, relating to pensions plans to read in pertinent part as follows:

**Section 6.13-11D PENSION PLANS.**

Firemen and Policemen Pension Fund of El Paso. The City shall continue to augment the Firemen and Policemen Pension Fund of El Paso in a manner consistent with the laws of Texas. To augment the Firemen and Policemen Pension Fund, the Council shall in each fiscal year beginning after November 2022, appropriate no less than eighteen percent of the total amount expended for wages of the participants, and may increase this contribution rate as allowed by the relevant state law requirements based on a qualified actuary's report; provided, however, that in the event age limits for participation in the pension fund, or any division of the fund, are increased as permitted by law and the raising of the age limits causes an increase in funding costs as determined by an actuary, the City shall appropriate an amount equal to such cost increase notwithstanding that such increased appropriation may exceed the otherwise determined percent of the total amount expended for wages of the participants.

**City of El Paso Special Election for Charter Amendment**  
**Ballot Proposition L**

Should section 6.13-11D relating to the police and fire pension fund be amended to establish that the City of El Paso shall contribute to the El Paso Policemen and Firemen Pension Fund no less than eighteen percent of the total amount expended for wages of the participants, and any increase to the contribution rate shall be as allowed by state law?

YES ( )

NO ( )

**SECTION 2 – BALLOTS**

The official ballots for said election shall be prepared in accordance with the Texas Election Code so as to permit the electors to vote "YES" or "NO" on the proposition, with the ballots to contain such provisions, markings and language as required by law, and with the proposition to be expressed substantially as set forth in section 1, above.

**SECTION 3 – EARLY VOTING CLERK**

Lisa Wise, El Paso County Elections Administrator, 500 E. San Antonio, Suite 314, El Paso, Texas, 79901, is hereby appointed as Early Voting Clerk. Applications for ballot by mail must be received no later than the close of business on October 28, 2022, sent to this address.



## **SECTION 4 – EARLY VOTING**

Early voting by personal appearance shall be conducted at the El Paso County Courthouse, located at 500 E. San Antonio, El Paso, Texas 79901. In addition, early voting may also occur at such early voting polling places as are designated herein or otherwise designated by the El Paso County Elections Administrator and posted at City Hall by the City Clerk. The locations and hours for early voting by personal appearance shall be authorized for such election as set forth in Exhibit “A,” which may be amended.

In addition, mobile voting stations may be authorized and used for early voting at publicly owned buildings in the City as established by the El Paso County Elections Administrator. The City Clerk is authorized to make corrections or revisions to the list of these mobile stations, including the respective hours for early voting by personal appearance at these stations. The City Clerk is further authorized to make corrections or revisions to the list of early voting stations as set forth above, including the respective hours for early voting by personal appearance at these stations, and revise and correct all election notices regarding the early voting locations and the mobile voting stations, and the dates and times for such voting.

For purposes of processing ballots cast in early voting, the election officers for the Early Voting Ballot Board shall be appointed and designated in accordance with the provisions of the election agreement with El Paso County.

## **SECTION 5 – NOTICE OF ELECTION**

The City Clerk shall give notice of such election by posting a notice of such election in English and Spanish in the Office of the City Clerk as provided by law and by publishing a copy of said notice in both English and Spanish in a newspaper in the City as required by law. Additionally, in accordance with Section 9.004(c) of the Local Government Code, notice shall be published in a newspaper of general circulation in El Paso on the same day, in each of two consecutive weeks, with the first publication occurring on or before the 14th day before election day. The notice shall contain a substantial copy of the proposed amendment.

The City Clerk shall deliver notice of this election to the County Clerk and voter registrar of El Paso County no later than Monday, October 24, 2022, or as otherwise required by law.

## **SECTION 6 – ELECTION SERVICES CONTRACT AND PROCEDURAL MATTERS**

The City Manager is hereby authorized to execute the necessary contract(s) and agreements, joint or otherwise, with the El Paso County Elections Administrator, or any other public entity, for the purpose of having El Paso County furnish all or any portion of the election services and equipment needed by the City Clerk to conduct the election. The contract document and election services provided therein shall conform to Chapter 31, Subchapter D, of the Texas Election Code and all other applicable statutes and laws.

The election services contract with the County shall provide (a) the type of electronic voting equipment to be used for early voting by personal appearance and on election day, (b)

notification and training for election judges and clerks, (c) an estimate and final payment terms for the election services provided, (d) agreements for early voting equipment and voting machine rental, and (e) other procedures necessary to conduct the election.

Matters contained in this ordinance relating to discretionary, procedural matters may be amended by approval of the City Manager, and procedural matters not established by this ordinance will be established by resolution of City Council.

### **SECTION 7 – VOTING MACHINES AND ELECTION RESULTS**

Voting machines used for the conduct of the election, shall be procured, maintained, operated, sealed and the votes therefrom tabulated pursuant to procedures established and authorized by the laws of the State of Texas.

The results of the election shall be certified, canvassed, and returned in the form and manner prescribed by law.

### **SECTION 8 – OTHER ACTION AND COMPLIANCE WITH APPLICABLE LAWS**

The City Manager and City Clerk, in consultation with the City Attorney, are hereby authorized and directed to take any additional action necessary to comply with provisions of the Texas Election Code or other state and federal statutes and constitutions in carrying out the conduct of the election, whether or not expressly authorized herein.

### **SECTION 9 – SEVERABILITY**

That should any part, section, subsection, paragraph, sentence, clause or phrase contained in this ordinance be held to be unconstitutional or of no force and effect, such holding shall not affect the validity of the remaining portion of this ordinance, but in all respects said remaining portion shall be and remain in full force and effect.

### **SECTION 10 – EFFECTIVE DATE**

This Ordinance shall be in force and effect from and after the date of its adoption, and it is so ordained.

APPROVED this \_\_\_\_ day of August, 2022.

CITY OF EL PASO

---

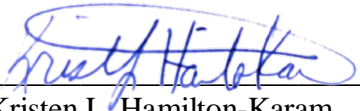
Oscar Leeser  
Mayor

ATTEST:

---

Laura D. Prine  
City Clerk

APPROVED AS TO FORM:



---

Kristen L. Hamilton-Karam  
Senior Assistant City Attorney

ORDINANCE NO. \_\_\_\_\_

**AN ORDINANCE OF THE CITY COUNCIL OF THE CITY OF EL PASO, TEXAS, ORDERING A SPECIAL ELECTION FOR THE SUBMISSION OF CHARTER AMENDMENTS TO SECTION 2.2C TO ALLOW PERSONS TO SERVE TWO FULL TERMS AS MAYOR OR DISTRICT REPRESENTATIVE IF SUCH PERSON CARRIED OUT AN UNEXPIRED TERM; SECTION 3.18 TO ALLOW CITY COUNCIL TO AUTHORIZE LEASES FOR 40 YEARS OR LESS BY RESOLUTION OR ORDINANCE; SECTION 3.5A TO ALLOW COUNCIL TO RESCHEDULE MEETINGS FOR HOLIDAYS AND ALLOW THE MAYOR TO CANCEL A COUNCIL MEETING IF REQUIRED DUE TO DECLARED EMERGENCY; SECTION 3.9B, 3.10B, AND 6.1-12 TO ALIGN TO STATE LAW AND UPDATE OBSOLETE REFERENCES; SECTION 3.11 TO REMOVE THE REQUIREMENT FOR A SECOND PETITION IN INITIATIVES, AND PROVIDE A PROCEDURE FOR CITIZENS TO INITIATE CITY ORDINANCES; SECTION 1.2, 3.5E, 3.6, 4.1B, 4.3 AND 7.3 TO AUTHORIZE THE MAYOR TO VOTE ON ALL COUNCIL ITEMS, REMOVING THE TIE-BREAKING AND VETO CAPACITY; SECTION 6.1-4 TO AUTHORIZE THE CITY TO CREATE A POLICY REGARDING MEMBERSHIP ON THE CIVIL SERVICE COMMISSION TO REFLECT THE COMMUNITY AND CITY WORKFORCE; SECTIONS 6.2-2 AND 6.2-3 TO ALIGN THE EMPLOYEE SERVING AS CIVIL SERVICE COMMISSION RECORDER WITH OTHER EMPLOYEES CARRYING OUT SIMILAR DUTIES; SECTION 6.7-1 AND 6.8-1 TO ALLOW THE CITY TO ESTABLISH MORE FLEXIBLE POLICIES IN HIRING EMPLOYEES; SECTION 6.13-11D TO ESTABLISH THE CITY CONTRIBUTION TO THE POLICE AND FIRE PENSION FUND OF NO LESS THAN 18% OF THE WAGES OF THE PARTICIPANTS, AND REMOVE THE LIMIT ON THE CITY'S CONTRIBUTION; SUCH ELECTION TO BE HELD WITHIN THE CITY, ON NOVEMBER 8, 2022; MAKING PROVISIONS FOR THE CONDUCT OF THE ELECTION; AND AUTHORIZING A CONTRACT WITH EL PASO COUNTY TO FURNISH ELECTION SERVICES AND EQUIPMENT; PROVIDING FOR SEVERABILITY AND SETTING AN EFFECTIVE DATE.**

**WHEREAS,** the City Council appointed a nine (9) member Ad Hoc Charter Advisory Committee in January 2022 to assist in the review and to make recommendations on potential charter amendments; and

**WHEREAS,** the Ad Hoc Charter Advisory Committee reviewed proposed Charter Amendments approved by a majority of the City Council and the Committee met from February 2022 through May 2022 to review the City Charter and in May 2022, the Committee finalized its report of its findings in writing, and presented its proposed amendments to the City Council; and

**WHEREAS,** the City Council has reviewed the proposed Amendments by the Committee and the City Council of the City of El Paso, Texas has determined it appropriate to

submit a proposed amendment to the existing City Charter of the City of El Paso to the qualified voters of the City for their adoption or rejection thereof pursuant to Section 9.004(a) of the Texas Local Government Code; and

**WHEREAS**, Section 9.04(b) of the Texas Local Government Code requires that an ordinance be approved ordering said election to be held on the first authorized uniform election date prescribed by the Texas Election Code and establishing the procedure to be followed in said election; and

**WHEREAS**, Section 41.001 of the Texas Election Code establishes November 8, 2022, as a uniform election date for the purposes of conducting an election; and

**WHEREAS**, pursuant to Texas Local Government Code Section 9.004(e), more than one amendment may be combined in one ballot proposition as long as the amendments contain only one subject; and

**WHEREAS**, pursuant to the Texas Local Government Code Section 9.004 a ballot for proposed charter amendments shall be prepared so that a voter may approve or disapprove any one or more amendments without having to approve or disapprove all of the amendments; and

**WHEREAS**, during a public meeting held on August 2, 2022, the City Council considered and approved for public vote, in the form of a ballot proposition, the following Charter amendments after considering recommendations by the 2022 Ad Hoc Charter Advisory Committee; and

**WHEREAS**, the City Council of the City of El Paso, Texas, hereby directs City staff to publish notice of the special charter election in a newspaper of general circulation in the City on the same day in each of two (2) successive weeks, the date of the first publication to be not less than fourteen (14) days prior to the date of the November 8, 2022 election, in compliance with Section 9.004(c) of the Texas Local Government Code.

**NOW, THEREFORE, BE IT ORDAINED BY THE CITY COUNCIL OF THE CITY OF EL PASO, TEXAS:**

**SECTION 1 – CHARTER AMENDMENT ELECTION CALLED**

The El Paso City Council does hereby order an election to submit to the voters of the City of El Paso proposed amendments to the City Charter, to be held on Tuesday, November 8, 2022. That such election shall be held at the precincts and the polling places designated in Exhibit "A" or such other locations as may be designated prior to the election by the City Council, attached hereto and made a part hereof for all purposes, and said polling places shall open at 7 a.m. and remain open until 7 p.m. on the day of the election.

That at such election, the following amendments to the Charter of the City of El Paso ("Propositions") shall be submitted to the qualified voters of the City and official ballots for the election shall be prepared in accordance with the Texas Election Code so as to permit the

electors to vote for or against the proposed amendment, and with such proposition to be expressed substantially as follows:

**CITY OF EL PASO PROPOSITION A**

**Text of Amendment**

Amending Section 2.2C of the City Charter, relating to term limits for the Mayor and District Representatives, to read in pertinent part as follows:

**Section 2.2C LIMITATION.**

No Mayor or Representative may hold such office for more than a total of ten years throughout their lifetime, however, a person who serves an unexpired term due to a Mayor or Representative's resignation will be allowed to serve two full four-year terms, regardless of whether it results in more than a total of ten years.

**City of El Paso Special Election for Charter Amendment  
Ballot Proposition A**

Should section 2.2C of the City Charter, relating to term limits, be amended to provide that a person who serves an unexpired term due to a Mayor or Representative's vacancy be allowed to serve two full four-year terms, regardless of whether it results in more than a total of ten years served throughout their lifetime?

YES ( )

NO ( )

**CITY OF EL PASO PROPOSITION B**

**Text of Amendment**

Amending Section 3.1 of the City Charter, relating to the creation; composition; powers and duties of City Council, to read in pertinent part as follows:

**Section 3.1 – CREATION; COMPOSITION; POWERS AND DUTIES**

There shall be a City Council consisting of District Representatives and the Mayor. The Council shall have legislative powers, and the power and duty to select, direct, and regularly evaluate the City Manager, as well as such other and specific powers and duties as may be provided by law or this Charter. Each Representative shall have the discretion and sole authority to appoint and remove ~~a legislative aide~~ district office staff.

**City of El Paso Special Election for Charter Amendment  
Ballot Proposition B**

Should section 3.1 of the City Charter, relating to creation, composition; powers and duties of Council be amended to allow City Council Representatives to appoint and remove district office staff?

YES ( )

NO ( )

## **CITY OF EL PASO PROPOSITION C**

### **Text of Amendment**

Amending Section 3.18 of the City Charter, relating to the use of ordinances, to read in pertinent part as follows:

#### **Section 3.18 LEASE; FRANCHISE, AND CONVEYANCE.**

The right of control, ownership and use of streets, alleys, parks and public places of the City is declared to be inalienable except as provided by ordinance passed by the Council and except for uses of less than thirty days which may have a separate approval process as established by ordinance.

Any authorization ordinance providing for the conveyance, lease, or grant of a franchise regarding the property of the City shall provide for payment to the City of a reasonable fee as consideration for that conveyance, lease, or franchise.

Any sale of City owned property in fee simple, franchise or lease for an initial term longer than forty years shall be approved by ordinance.

In addition, any authorization ordinance providing for a the lease or franchise shall must provide that: ~~1. At the termination of the lease or franchise, the property involved, together with any improvements thereto, made or erected during the term of the lease or franchise, shall (either without further compensation or upon payment of a fair valuation therefore as determined by the terms of the ordinance), become the property of the City; and 2. Every lease or franchise~~ the City may ~~be~~ revoked ~~it by the City~~ if necessary to secure efficiency of public service at a reasonable rate, ~~or to~~ and must assure that the property is maintained in good ~~order~~ condition throughout the life of the lease or franchise grant.

### **City of El Paso Special Election for Charter Amendment** **Ballot Proposition C**

Should section 3.18 of the City Charter relating to Leases, Franchises, and Conveyances be amended to authorize Council to lease City owned property for 40 years or less by Council resolution or ordinance?

YES ( )

NO ( )

**CITY OF EL PASO PROPOSITION D**

**Text of Amendment**

Amending Section 3.5 of the City Charter, relating to City Council Procedures and Rules, to read in pertinent part as follows:

**Section 3.5 A CITY COUNCIL PROCEDURES AND RULES**

Meetings. Regular meetings of the Council shall be held in Council chambers no less than once every other week at such times as may be prescribed by resolution, except that Council may reschedule meetings by resolution to allow for City holidays, but must have no less than two regular meetings per month. The Mayor may cancel a meeting if necessary due to a Federal, State or Local declared emergency.

**City of El Paso Special Election for Charter Amendment**  
**Ballot Proposition D**

Should section 3.5A of the City Charter be amended to allow Council to reschedule meetings by resolution to allow for City holidays but shall hold no less than two regular meetings per month?

YES ( )

NO ( )

**CITY OF EL PASO PROPOSITION E**

**Text of Amendment**

**Section 3.5 A CITY COUNCIL PROCEDURES AND RULES**

Meetings. Regular meetings of the Council shall be held in Council chambers no less than once every other week at such times as may be prescribed by resolution, except that Council may reschedule meetings by resolution to allow for City holidays, but must have no less than two regular meetings per month. The Mayor may cancel a meeting if necessary due to a Federal, State or Local declared emergency.

**City of El Paso Special Election for Charter Amendment**  
**Ballot Proposition E**

Should section 3.5A of the City Charter be amended to allow the Mayor to cancel a meeting if necessary due to a Federal, State or Local declared emergency?



YES ( )

NO ( )

## CITY OF EL PASO PROPOSITION F

### Text of Amendment

Amending Sections 3.9B relating to Ordinances, 3.10B relating to emergency ordinances, 6.1-12 relating to civil service hearing officers to read in pertinent part as follows:

#### **Section 3.9 ORDINANCES IN GENERAL.**

B. Legislative Procedure. Except as provided in Section 3.13, an ordinance may be introduced by any Council member at any meeting of the Council. A proposed ordinance must be filed with the City Clerk in sufficient time for inclusion on the agenda for the Council meeting at which it is to be introduced. Upon such filing the City Clerk shall distribute copies to each member of the Council and to the City Manager. ~~A reasonable number of copies shall be available in the office of the City Clerk, and at such other public places as the Council may designate, for examination by interested persons.~~ No ordinance shall be adopted finally except at a regular open meeting of the Council following notice, publication, and a public hearing. The notice shall contain:

1. The proposed ordinance or a brief summary thereof;
2. The places where copies of it have been filed and the times when they are available for public examination; and
3. The time and place for the public hearing. The notice shall be published by any contemporary means of information sharing, including but not limited to publication in a newspaper of general circulation in the City or placement on a website at least five days prior to the public hearing. The hearing may be held by a designated Council committee or the Council separately or in connection with any Council meeting and may be adjourned to a specified time. All interested persons present shall have an opportunity to be heard. As soon as practicable after adoption of any ordinance, the City Clerk shall publish it again, with notice of its adoption, in abstract form, by any contemporary means of information sharing. These abstracts must state, at a minimum, the purpose of the ordinance and, where penal, the penalty provided. In any event, the publication must be written so as to be understood by an average person.

#### **Section 3.10B EMERGENCY ORDINANCES.**

Procedures. An emergency ordinance shall be introduced in the form and manner prescribed for ordinances generally, except that it may be introduced on ~~one two~~ one hour's public notice, and shall contain, after the enacting clause, a declaration stating that an emergency exists and describing the emergency in clear and specific terms. An emergency ordinance may be adopted with or without amendment or rejected at the meeting at which it is introduced, but the unanimous vote of the ~~Council members Representatives~~ Council members present, ~~and the consent of the Mayor,~~ shall be required for adoption.

**Section 6.1-12 HEARING OFFICERS.**

The Commission will appoint one or more compensated hearing officers to hear appeals made under Section 6.13-4. The need for hearing officers in excess of one shall be determined jointly by the Commission and the City Manager. Hearing officers will perform those duties and functions necessary to render a recommendation to the Commission on the matter in dispute.

The hearing officers will serve at the Commission’s pleasure, and ~~will not be classified. Reasonable compensation shall be paid by the City. will be procured through the City's procurement process.~~

**City of El Paso Special Election for Charter Amendment**  
**Ballot Proposition F**

Shall Sections 3.9B, 3.10B, 6.1-12of the City Charter be amended to eliminate provisions which have become inoperative because they have been superseded by state law; replace obsolete references and update terminology to current legal usage?

YES ( )

NO ( )

**CITY OF EL PASO PROPOSITION G**

**Text of Amendment**

Amending Section 3.11 of the City Charter, relating to Initiatives to read in pertinent part as follows:

**Section 3.11 INITIATIVE.**

Any five registered voters, referred to in this section as the committee, may initiate an ordinance that complies with federal, state and local law by filing with the City Clerk a statement that they intend to circulate a petition, however no ordinance may be initiated through this process regarding required appropriation or allocation of City funds, zoning or rezoning, levy of taxes, setting utility rates, purchase or sale of an interest in real property or granting a franchise. Such statement must include the names and addresses of the committee members, the full text of the proposed ordinance, and the designated lead committee member.

The City Clerk shall place the proposed Ordinance on the City Council Agenda for introduction within thirty days after receiving the statement, followed by a public hearing at the second

reading. If City Council fails to adopt the ordinance, or adopts it with amendments, the City Clerk will notify the committee through the lead committee member.

If the committee still wishes to seek adoption of the ordinance after Council fails to adopt, or does not agree to Council's amendments, it will then have 180 calendar days after notice from the City Clerk to complete the petition by gathering signatures in the form required by state law, including but not limited to original signature, printed name, residence address and date of birth or voter registration of ~~Whenever~~ a number of registered voters equal to at least five percent of the voters who voted in the last general City election, sign a ~~The~~ petition must setting ~~forth~~ the precise content of ~~an~~ the ~~ordinance desired by the~~ petitioners. ~~signers.~~

Within thirty working days, the City Clerk shall review the petition to verify if it meets all requirements, and if authenticated with the required number of signatures, the ~~Council~~ must place that ordinance on the agenda of a Council meeting to be held within thirty working days of the ~~receipt, authentication~~ by the City Clerk, of the petition bearing the authenticated names and addresses of the petitioners. Such an item shall be treated by the Council exactly as any other proposed ordinance.

Should an ordinance proposed by such petition not be enacted by the If Council does not adopt, or should it be enacted adopts the proposed ordinance in an amended form, a second petition, signed by a number of registered voters equal to at least five percent of the voters who voted in the last general City election, may be submitted to the City Clerk and that official shall have twenty working days in which to authenticate the signatures and thereafter must place the re proposed ordinance on the ballot at the next citywide general election specified in State law, if the proposal receives ~~d~~ the favorable vote of a majority of those voting in that election it shall thereupon become a City ordinance.

The Council is not obliged to consider the same ordinance initiated by petition, or one that is substantially the same, more often than once in: two years.

**City of El Paso Special Election for Charter Amendment  
Ballot Proposition G**

Should section 3.11 relating to the initiative petition of the City Charter be amended to remove the requirement for a second petition, and institute a process for the public to initiate a City ordinance?

YES ( )

NO ( )

**CITY OF EL PASO PROPOSITION H**

**Text of Amendment**

Amending Section 1.2 relating to Definitions, 3.5E relating to City Council Procedures

and Rules, 3.6 relating to Legislative Committees, 4.1B Power of the Mayor, 4.3 relating to Mayor Pro Tempore and 7.3 relating to budget procedures of the City Charter effective the first City Council meeting January of 2025, to read in pertinent part as follows:

## Section 1.2 - DEFINITIONS

As used in this Charter, the term "laws of Texas" shall include the Constitution and statutes of the State of Texas, the common law as it exists in the State of Texas, and appropriate case law. As used herein, "State" shall mean the State of Texas; "City" shall mean the City of El Paso; "City Council" or "Council" shall mean the Mayor and Representatives of the City of El Paso, with the Mayor being a ~~non~~-voting member of Council; ~~provided, however, the Mayor shall not be considered a member of Council for items and matters requiring a super-majority vote of all members of the governing body~~; and "department" shall mean any City agency, office, bureau or other organizational unit.

## Section 3.5 E CITY COUNCIL PROCEDURES AND RULES

~~Veto-Effective Date.~~ Ordinances and resolutions finally adopted by the Council shall be filed in the office of the City Clerk and signed by the Mayor before they take effect. ~~If the Mayor vetoes the ordinance or resolution, reasons shall be set forth by the Mayor in writing, and the ordinance or resolution with those reasons shall be returned to the Council. However, the Mayor shall not have any veto power over any City Council action which removes the City Manager or the City Attorney. To override the Mayor's veto, three-fourths of all of the Representatives must vote in favor of the returned ordinance or resolution, in which event the adopted ordinance or resolution shall become law.~~ If the Mayor shall either fail to ~~approve or object in writing~~ sign ~~to~~ any adopted ordinance or resolution within five days after it has been filed with the City Clerk, exclusive of the day of filing, it shall become law.

## Section 3.6 LEGISLATIVE COMMITTEES

A. The ~~Representatives~~ members of Council may resolve themselves into committees, both standing and special, when this is convenient for the conduct of legislative business, including the investigative powers described in Section 3.8. Rules governing the organization and procedures of these committees shall be made by the Council, ~~and the Mayor shall have no power to veto any of those rules except upon grounds of illegality.~~

## Section 4.1B POWERS OF THE MAYOR

The Mayor shall be a voting member of City Council and preside over the City Council meetings, having the power to propose legislation; represent the City in intra-governmental and intergovernmental relationships; appoint with the consent of the Council the members of citizen advisory boards and commissions; make appointments and perform duties pursuant to federal and state law; present an annual state of the City message, ~~break tie votes, veto legislation except for any City Council action which removes the City Manager or the City Attorney~~ convene the Council in special session and perform other duties specified by the Council.

**Section 4.3 – MAYOR PRO TEMPORE**

A. At the first meeting upon the start of new terms of office following each general election, the Council shall elect from among the Representatives a Mayor Pro Tempore, who shall hold that office for a two year term. Should the office of Mayor Pro Tempore become vacant, the Council shall elect a new Mayor Pro Tempore.

B. During the absence or disability of the Mayor, the Mayor Pro Tempore shall act as Mayor, ~~but shall vote as a Representative, and shall have no veto power.~~

**Section 7.3 – BUDGET PROCEDURES**

The procedures here stated shall govern adoption of the annual budget and the appropriations of monies pursuant thereto.

D. Adoption. The budget shall be adopted by resolution, ~~subject to the Mayor's veto,~~ not later than the day before the first day of the City's fiscal and budget year; but, in the event the budget is not adopted, the appropriation for personnel and essential operating supplies made in the previous year shall be extended until the new budget is adopted.

**City of El Paso Special Election for Charter Amendment**  
**Ballot Proposition H**

Should section 1.2, 3.5E , 3.6, 4.1B, 4.3, and 7.3 of the City Charter be amended to authorize the Mayor to vote on all City Council agenda items and remove the Mayor’s tie-breaking and veto capacity effective the first City Council meeting of January 2025?

YES ( )

NO ( )

**CITY OF EL PASO PROPOSITION I**

**Text of Amendment**

Amending Section 6.1-4 of the City Charter, relating to Civil Service qualifications to read in pertinent part as follows:

**Section 6.1-4 QUALIFICATIONS.**

Members of the Commission must be residents of the City at the time of their appointment and remain a resident of the City throughout their term of office. No Commissioner shall be related in any manner described in Article III, Section 3.3 B to any employee of the City, the Public Service Board, or any entity that has a contract with the City to operate or manage any City facility or department, nor hold any salaried public office or other employment compensated by the City, and any violation of this provision shall be deemed malfeasance in office and cause for removal therefrom. ~~At least two Commissioners must hold or have retired from positions other than managerial or professional. The City should adopt rules that reflect the diversity of the community and City workforce.~~ No more than three Commissioners may be former city

employees, and any such Commissioners are not eligible for appointment until two years following separation from the City. Any commissioner may be either actively employed or retired.

**City of El Paso Special Election for Charter Amendment**  
**Ballot Proposition I**

Should 6.1-4 of the City Charter be amended to allow for appointment of Civil Service Commissioners that reflect the diversity of the community and City workforce?

YES ( )

NO ( )

**CITY OF EL PASO PROPOSITION J**

**Text of Amendment**

Amending Section 6.2-2 of the City Charter, relating to the unclassified services and 6.2-3B, relating to appointment and removal of unclassified personnel to read in pertinent part as follows:

**Section 6.2-2 UNCLASSIFIED SERVICES.**

The unclassified services shall include only the following positions:

A. The City Attorney, Assistant City Attorneys, law clerks and paralegal personnel;

B. The Mayor's executive secretary(s) and Executive Assistant(s);

~~C. Hearing officer(s) and the Commission Recorder;~~

~~D. C. All elected officials;~~

~~E. D. Members of all City boards, commissions, and committees who serve without compensation;~~

~~F. E. Employees hired by contract, and short-term or limited-funding grant-funded employees as designated by the City Manager and hired on or after the effective date of this amendment;~~

~~G. F. The City Manager;~~

~~H. G. All executive level employees, and executive staff or salaried professional employees reporting directly to the City Manager;~~

**I. H** Employees hired on or after May 18, 2007 who work at the Metropolitan Planning Organization; and

**J. I.** Persons given provisional and temporary appointments who are not classified employees at the time of such appointment.

**K. J.** A person hired solely as a District Representative's legislative aide for the limited period of the term of office for that District Representative.

### **Section 6.2-3 – APPOINTMENT AND REMOVAL OF UNCLASSIFIED PERSONNEL**

B. Except as otherwise provided by law or in this Charter, unclassified personnel may be removed by the City Manager or designee, who may establish written procedures for removal.; ~~except for hearing officers and the Commission Recorder, who may be removed only by a majority vote of the commissioners.~~

#### **City of El Paso Special Election for Charter Amendment** **Ballot Proposition J**

Should Section 6.2-2 relating to Unclassified Services and 6.2-3 relating to appointment and removal of unclassified personnel be amended to align the person carrying out the role of civil service commission recorder with all other unclassified City employees who may be removed by the City Manager or designee in accordance with the City Charter?

YES ( )

NO ( )

### **CITY OF EL PASO PROPOSITION K**

#### **Text of Amendment**

Amending Section 6.7-1 and 6.8-1 of the City Charter, relating to penalty for deceit in examinations, examinations and eligibility to read in pertinent part as follows:

#### **Section 6.7-1 PENALTY FOR DECEIT IN EXAMINATION.**

~~An applicant in any examination who uses or attempts to use any unfair or deceitful means to pass the examination shall be excluded from further participation in the examination and the papers not rated, except as may be provided in the applicable Rules or policies and procedures.~~  
(Reserved.)

**Section 6.8-1 EXAMINATION AND ELIGIBILITY**

The Human Resources Director shall establish administrative policies and procedures for the promotion process, ~~including examination~~ and eligibility, consistent with the provisions of this Article and all applicable federal and state employment laws. ~~Promotion to any position in the Civil Service shall be by examination weighed by seniority and performance record, except as otherwise provided in the Charter or Rules. Eligibility criteria and rating factors for promotions shall be established by Rule and shall include a credit for seniority.~~

**City of El Paso Special Election for Charter Amendment**  
**Ballot Proposition K**

Should Section 6.7-1 be deleted and 6.8-1 relating to Examinations of the City Charter be amended to allow the City to establish Civil Service Rules, policies and procedures for the promotion of City employees?

YES ( )

NO ( )

CITY OF EL PASO PROPOSITION L

**Text of Amendment**

Amending Section 6.13-11D of the City Charter, relating to pensions plans to read in pertinent part as follows:

**Section 6.13-11D PENSION PLANS.**

Firemen and Policemen Pension Fund of El Paso. The City shall continue to augment the Firemen and Policemen Pension Fund of El Paso in a manner consistent with the laws of Texas. To augment the Firemen and Policemen Pension Fund, the Council shall in each fiscal year beginning after ~~February, 1968,~~ November 2022, appropriate ~~no less than eighteen percent of the total amount expended for wages of the participants, and may increase this contribution rate as allowed by the relevant state law requirements based on a qualified actuary’s report; an amount equal to three times the amount paid into the fund by the participants therein; provided that the amount contributed by the City shall not exceed eighteen percent of the total amount expended for salaries of the participants.;~~ no less than eighteen percent of the total amount expended for wages of the participants, and may increase this contribution rate as allowed by the relevant state law requirements based on a qualified actuary’s report; provided ~~further,~~ however, that in the event age limits for participation in the pension fund, or any division of the fund, are increased as permitted by law and the raising of the age limits causes an increase in funding costs as determined by an actuary, the City shall appropriate an amount equal to such cost increase notwithstanding that such increased appropriation may exceed ~~the otherwise determined eighteen percent of the total amount expended for salaries of the participants, but such increased appropriation shall in no case exceed eighteen and one half~~ the otherwise determined ~~eighteen percent of the total amount expended for salaries of the participants, but such increased appropriation shall in no case exceed eighteen and one half~~ percent of the total amount expended for wages ~~salaries~~ of the participants.



**City of El Paso Special Election for Charter Amendment**  
**Ballot Proposition L**

Should section 6.13-11D relating to the police and fire pension fund be amended to establish that the City of El Paso shall contribute to the El Paso Policemen and Firemen Pension Fund no less than eighteen percent of the total amount expended for wages of the participants, and any increase to the contribution rate shall be as allowed by state law ?

YES ( )

NO ( )

**SECTION 2 – BALLOTS**

The official ballots for said election shall be prepared in accordance with the Texas Election Code so as to permit the electors to vote "YES" or "NO" on the proposition, with the ballots to contain such provisions, markings and language as required by law, and with the proposition to be expressed substantially as set forth in section 1, above.

**SECTION 3 – EARLY VOTING CLERK**

Lisa Wise, El Paso County Elections Administrator, 500 E. San Antonio, Suite 314, El Paso, Texas, 79901, is hereby appointed as Early Voting Clerk. Applications for ballot by mail must be received no later than the close of business on October 28, 2022, sent to this address.

**SECTION 4 – EARLY VOTING**

Early voting by personal appearance shall be conducted at the El Paso County Courthouse, located at 500 E. San Antonio, El Paso, Texas 79901. In addition, early voting may also occur at such early voting polling places as are designated herein or otherwise designated by the El Paso County Elections Administrator and posted at City Hall by the City Clerk. The locations and hours for early voting by personal appearance shall be authorized for such election as set forth in Exhibit "A," which may be amended.

In addition, mobile voting stations may be authorized and used for early voting at publicly owned buildings in the City as established by the El Paso County Elections Administrator. The City Clerk is authorized to make corrections or revisions to the list of these mobile stations, including the respective hours for early voting by personal appearance at these stations. The City Clerk is further authorized to make corrections or revisions to the list of early voting stations as set forth above, including the respective hours for early voting by personal appearance at these stations, and revise and correct all election notices regarding the early voting locations and the mobile voting stations, and the dates and times for such voting.

For purposes of processing ballots cast in early voting, the election officers for the Early Voting Ballot Board shall be appointed and designated in accordance with the provisions of the election agreement with El Paso County.

#### **SECTION 5 – NOTICE OF ELECTION**

The City Clerk shall give notice of such election by posting a notice of such election in English and Spanish in the Office of the City Clerk as provided by law and by publishing a copy of said notice in both English and Spanish in a newspaper in the City as required by law. Additionally, in accordance with Section 9.004(c) of the Local Government Code, notice shall be published in a newspaper of general circulation in El Paso on the same day, in each of two consecutive weeks, with the first publication occurring on or before the 14th day before election day. The notice shall contain a substantial copy of the proposed amendment.

The City Clerk shall deliver notice of this election to the County Clerk and voter registrar of El Paso County no later than Monday, October 24, 2022, or as otherwise required by law.

#### **SECTION 6 – ELECTION SERVICES CONTRACT AND PROCEDURAL MATTERS**

The City Manager is hereby authorized to execute the necessary contract(s) and agreements, joint or otherwise, with the El Paso County Elections Administrator, or any other public entity, for the purpose of having El Paso County furnish all or any portion of the election services and equipment needed by the City Clerk to conduct the election. The contract document and election services provided therein shall conform to Chapter 31, Subchapter D, of the Texas Election Code and all other applicable statutes and laws.

The election services contract with the County shall provide (a) the type of electronic voting equipment to be used for early voting by personal appearance and on election day, (b) notification and training for election judges and clerks, (c) an estimate and final payment terms for the election services provided, (d) agreements for early voting equipment and voting machine rental, and (e) other procedures necessary to conduct the election.

Matters contained in this ordinance relating to discretionary, procedural matters may be amended by approval of the City Manager, and procedural matters not established by this ordinance will be established by resolution of City Council.

#### **SECTION 7 – VOTING MACHINES AND ELECTION RESULTS**

Voting machines used for the conduct of the election, shall be procured, maintained, operated, sealed and the votes therefrom tabulated pursuant to procedures established and authorized by the laws of the State of Texas.

The results of the election shall be certified, canvassed, and returned in the form and manner prescribed by law.

#### **SECTION 8 – OTHER ACTION AND COMPLIANCE WITH APPLICABLE LAWS**

The City Manager and City Clerk, in consultation with the City Attorney, are hereby authorized and directed to take any additional action necessary to comply with provisions of the Texas Election Code or other state and federal statutes and constitutions in carrying out the conduct of the election, whether or not expressly authorized herein.

**SECTION 9 – SEVERABILITY**

That should any part, section, subsection, paragraph, sentence, clause or phrase contained in this ordinance be held to be unconstitutional or of no force and effect, such holding shall not affect the validity of the remaining portion of this ordinance, but in all respects said remaining portion shall be and remain in full force and effect.

**SECTION 10 – EFFECTIVE DATE**

This Ordinance shall be in force and effect from and after the date of its adoption, and it is so ordained.

APPROVED this \_\_\_\_ day of August, 2022.

CITY OF EL PASO

\_\_\_\_\_  
Oscar Leeser  
Mayor

ATTEST:

APPROVED AS TO FORM:

\_\_\_\_\_  
Laura D. Prine  
City Clerk

\_\_\_\_\_  
Kristen L. Hamilton-Karam  
Senior Assistant City Attorney



Legislation Text

---

File #: 22-963, Version: 1

---

**CITY OF EL PASO, TEXAS**  
**LEGISTAR AGENDA ITEM SUMMARY FORM**

**DISTRICT, DEPARTMENT, CONTACT INFORMATION:**

*Please choose District and Department from drop down menu. Please post exactly as example below.  
No Title's, No emails. Please use ARIAL 10 Font.*

**District 7**

Purchasing and Strategic Sourcing, Claudia A. Garcia, (915) 212-1218  
Capital Improvement Department, Yvette Hernandez, (915) 212-1860

**AGENDA LANGUAGE:**

*This is the language that will be posted to the agenda. Please use ARIAL 11 Font.*

The linkage to the Strategic Plan is subsection 7.2 - Improve competitiveness through infrastructure improvements impacting the quality of life.

**Award Summary:**

Discussion and action on the award of Solicitation 2022-0271 Ysleta Middle School Rapid Transit System (RTS) to ALLEN CONCRETE, LLC for an estimated award of \$625,384.55. The project consists of installation of school zone flashers along Independence Drive, Americans with Disability Act (ADA) ramps at multiple locations, and school zone signs will be upgraded to meet the Manual on Uniform Traffic Control Devices (MUTCD) standards at Ysleta Middle School. Bicycle lanes will be installed at Davis Dr. / Elvin Way between Alameda Avenue and Victor Lane. There will also be a hike & bike trail along Playa Lateral between Elvin Way and Jesuit Drive.

Department:	Capital Improvement
Award to:	ALLEN CONCRETE, LLC El Paso, TX
Item(s):	Base Bid I
Initial Term:	117 Consecutive Calendar Days
Base Bid:	\$625,384.55
Total Estimated Award:	\$625,384.55
Funding Source:	Capital Projects and Federal Highway Administration
Account:	190-4950-580270-38170- PCP21TRAN02
District(s):	7

This is a Low Bid procurement, unit price contract.

The Purchasing and Strategic Sourcing and Capital Improvement Department recommend award as indicated to ALLEN CONCRETE, LLC, the lowest responsive and responsible bidder.

It is requested that the City Manager be authorized to establish the funding sources and make any necessary budget transfers and execute any and all documents necessary for execution of this award.

Work under this unit price contract is only an estimated value and will be ordered, performed, invoiced, and paid by measured quantity. The actual cost of this contract may be higher or lower than the total estimated value and will be the sum total of unit prices at the end of the contract term.

As a part of this award, upon the review of the City Attorney, the City Engineer may without further authorization from City Council approve contract changes which are necessary for proper execution of the work and carrying out the intent of the project, which are in accordance with applicable law, do not make changes to the prices and are within the appropriate budget.

**CITY OF EL PASO, TEXAS  
AGENDA ITEM  
DEPARTMENT HEAD'S SUMMARY FORM**

**AGENDA DATE:** August 2, 2022  
**PUBLIC HEARING DATE:** Not Applicable

**CONTACT PERSON(S) NAME AND PHONE NUMBER:**

Yvette Hernandez, City Engineer, (915) 212-1860  
Claudia A. Garcia, Interim Director of Purchasing & Strategic Sourcing,  
(915) 212-1218

**DISTRICT(S) AFFECTED:** 7

**STRATEGIC GOAL:** No. 7. Enhance and sustain El Paso's Infrastructure Network

**SUBGOAL:** 7.2: Improve competitiveness through infrastructure improvements impacting the quality of life

**SUBJECT:**

Discussion and action on the award of Solicitation 2022-0271 Ysleta Middle School Rapid Transit System (RTS) to ALLEN CONCRETE, LLC for Base Bid I: \$625,384.55 for an estimated total amount of \$625,384.55.

**BACKGROUND / DISCUSSION:**

The Ysleta Middle School Rapid Transit System project consists of installation of school zone flashers along Independence Drive, Americans with Disabilities (ADA) ramps at multiple locations, and school zone signs will be upgraded to meet Manual on Uniform Traffic Control Device (MUTCD) standards at Ysleta Middle School. Bicycle lanes will be installed at Davis Dr. / Elvin Way between Alameda Avenue and Victor Lane. There will also be a hike & bike trail along Playa Lateral between Elvin Way and Jesuit Drive.

**SELECTION SUMMARY:**

Solicitation was advertised on April 19, 2022, April 26, 2022 and May 3, 2022. The solicitation was posted on City website on April 19, 2022. The email (Purmail) notification was sent out on April 21, 2022. There were a total sixty-nine (69) viewers online; four (4) proposals were received; all being from local suppliers.

**CONTRACT VARIANCE:**

N/A

**PROTEST**

No protest was received for this requirement.

**PRIOR COUNCIL ACTION:**

N/A

**AMOUNT AND SOURCE OF FUNDING:**

Amount: \$625,384.55  
Funding Source: Capital Projects and TxDOT  
Account: 190-4950-580270-38170- PCP21TRAN02

HAVE ALL AFFECTED DEPARTMENTS BEEN NOTIFIED?  X  YES \_\_\_ NO

**PRIMARY DEPARTMENT:** Capital Improvement

**SECONDARY DEPARTMENT:** Purchasing & Strategic Sourcing

---

\*\*\*\*\*REQUIRED AUTHORIZATION\*\*\*\*\*

**DEPARTMENT HEAD:**

*Yvette Hernandez*

---

Yvette Hernandez, City Engineer

**COUNCIL PROJECT FORM  
(Low Bid)**

\*\*\*\*\***POSTING LANGUAGE BELOW**\*\*\*\*\*

Please place the following item on the **REGULAR AGENDA** for the Council Meeting of **August 2, 2022**.

**STRATEGIC GOAL 7 – Enhance and sustain El Paso's Infrastructure Network**

The linkage to the Strategic Plan is subsection 7.2 - Improve competitiveness through infrastructure improvements impacting the quality of life

**Award Summary:**

Discussion and action on the award of Solicitation 2022-0271 Ysleta Middle School Rapid Transit System (RTS) to ALLEN CONCRETE, LLC for an estimated award of \$625,384.55. The project consists of installation of school zone flashers along Independence Drive, Americans with Disabilities (ADA) ramps at multiple locations, and school zone signs will be upgraded to meet Manual on Uniform Traffic Control Device (MUTCD) standards at Ysleta Middle School. Bicycle lanes will be installed at Davis Dr. / Elvin Way between Alameda Avenue and Victor Lane. There will also be a hike & bike trail along Playa Lateral between Elvin Way and Jesuit Drive.

Department:	Capital Improvement
Award to:	ALLEN CONCRETE, LLC El Paso, TX
Item(s):	Base Bid I
Initial Term:	117 Consecutive Calendar Days
Base Bid:	\$625,384.55
Total Estimated Award:	\$625,384.55
Funding Source:	Capital Projects and Federal Highway Administration
Account:	190-4950-580270-38170- PCP21TRAN02
District(s):	7

This is a Low Bid procurement, unit price contract.

The Purchasing & Strategic Sourcing and Capital Improvement Departments recommend award as indicated to ALLEN CONCRETE, LLC, the lowest responsive and responsible bidder.

It is requested that the City Manager be authorized to establish the funding sources and make any necessary budget transfers and execute any and all documents necessary for execution of this award.

Work under this unit price contract is only an estimated value and will be ordered, performed, invoiced, and paid by measured quantity. The actual cost of this contract may be higher or lower than the total estimated value and will be the sum total of unit prices at the end of the contract term.

As a part of this award, upon the review of the City Attorney, the City Engineer may without further authorization from City Council approve contract changes which are necessary for proper execution of the work and carrying out the intent of the project, which are in accordance with applicable law, do not make changes to the prices and are within the appropriate budget.



## Bid Tab Summary

### 2022-0271 Ysleta Middle School RTS

	Contractor	Base Bid I	Total Amount
1	Allen Concrete, LLC	\$625,384.55	\$625,384.55
2	Horizone Constuction 1 LTD	\$699,180.74	\$699,180.74
3	Del Mar Contracting, Inc.	\$787,343.60	\$787,343.60
4	Globe Builders, Inc.	\$826,828.75	\$826,828.75



# CITY OF EL PASO BID TABULATION FORM



**BID TITLE: YSLETA MIDDLE SCHOOL RTS**

**BID NO: 2022--0271**

**BID DATE: MAY 18, 2022**

**DEPARTMENT: CAPITAL IMPROVEMENT**

					Allen Concrete, LLC El Paso, TX BIDDER 1 OF 4		Del Mar Contracting, Inc. El Paso, TX BIDDER 2 OF 4		Globe Builders, Inc. El Paso, TX BIDDER 3 OF 4		
NO.	ITEM-CODE		BRIEF DESCRIPTION OF ITEM	UNIT	APPROX QTY.	UNIT PRICE	TOTAL AMOUNT	UNIT PRICE	TOTAL AMOUNT	UNIT PRICE	TOTAL AMOUNT
	ITEM NO.	CODE NO.									
<b>BASE BID UNIT PRICE SCHEDULE</b>											
1	100	6001	PREPARING ROW	AC	1	\$10,074.00	\$10,074.00	\$10,000.00	\$10,000.00	\$9,356.35	\$9,356.35
2	104	6017	REMOVING CONC (DRIVEWAYS)	SY	156	\$22.50	\$3,510.00	\$15.00	\$2,340.00	\$17.96	\$2,801.76
3	104	6029	REMOVING CONC (CURB OR CURB & GUTTER)	LF	455	\$2.50	\$1,137.50 Contractor's price: \$1,135.50	\$6.00	\$2,730.00	\$10.50	\$4,777.50
4	104	6036	REMOVING CONC (SIDEWALK OR RAMP)	SY	313	\$22.50	\$7,042.50	\$15.00	\$4,695.00	\$19.79	\$6,194.27
5	105	6015	REMOVING STAB BASE & ASPH PAV (8"-10")	SY	492	\$22.50	\$11,070.00	\$22.00	\$10,824.00	\$5.46	\$2,686.32
6	110	6001	EXCAVATION (ROADWAY)	CY	437	\$12.50	\$5,462.50	\$34.00	\$14,858.00	\$36.00	\$15,732.00
7	132	6002	EMBANKMENT (FINAL)(DENS CONT)(TY A)	CY	1,805	\$18.50	\$33,392.50	\$25.00	\$45,125.00	\$25.84	\$46,641.20
8	192	6017	VEGETATION BARRIER	SY	219	\$7.26	\$1,589.94	\$4.00	\$876.00	\$5.89	\$1,289.91
9	1002	6029	LANDSCAPE AMENITY (BOULDER)	EA	1	\$707.85	\$707.85	\$400.00	\$400.00	\$970.91	\$970.91
10	1005	6001	LOOSE AGGR FOR GROUNDCOVER (TYPE I)	CY	19	\$186.81	\$3,549.39	\$150.00	\$2,850.00	\$177.80	\$3,378.20
11	247	ELP1	FL BS (CMP IN PLACE) (TY A GR 1-2) (4")	SY	2,308	\$9.50	\$21,926.00	\$15.00	\$34,620.00	\$13.38	\$30,881.04
12	310	6005	PRIME COAT (AE-P)	GAL	491	\$7.00	\$3,437.00	\$9.00	\$4,419.00	\$7.10	\$3,486.10
13	3076	6040	D-GR HMA TY-D PG70-22	TON	294	\$138.00	\$40,572.00	\$175.00	\$51,450.00	\$109.20	\$32,104.80
14	401	6001	FLOWABLE BACKFILL	CY	35	\$162.00	\$5,670.00	\$186.00	\$6,510.00	\$135.60	\$4,746.00
15	416	6031	DRILL SHAFT (TRF SIG POLE) (30 IN)	LF	22	\$484.00	\$10,648.00	\$480.00	\$10,560.00	\$478.80	\$10,533.60
16	465	ELP1	DROP INLET GRATE AND FRAME	EA	3	\$11,000.00	\$33,000.00	\$1,100.00	\$3,300.00	\$18,700.80	\$56,102.40
17	466	6003	HEADWALL (CH - FW - 0) (DIA= 18 IN)	EA	1	\$5,900.00	\$5,900.00	\$4,000.00	\$4,000.00	\$6,487.56	\$6,487.56
18	500	6001	MOBILIZATION	LS	1	\$22,314.00	\$22,314.00	\$39,000.00	\$39,000.00	\$30,000.00	\$30,000.00
19	502	6001	BARRICADES, SIGNS AND TRAFFIC HANDLING	MO	6	\$3,500.00	\$21,000.00	\$8,000.00	\$48,000.00	\$14,330.78	\$85,984.68

238

Approved By: D.R  
Date: 6/2/2022



## CITY OF EL PASO BID TABULATION FORM



**BID TITLE: YSLETA MIDDLE SCHOOL RTS** **BID NO: 2022--0271**  
**BID DATE: MAY 18, 2022** **DEPARTMENT: CAPITAL IMPROVEMENT**

					Allen Concrete, LLC El Paso, TX BIDDER 1 OF 4		Del Mar Contracting, Inc. El Paso, TX BIDDER 2 OF 4		Globe Builders, Inc. El Paso, TX BIDDER 3 OF 4		
NO.	ITEM-CODE		BRIEF DESCRIPTION OF ITEM	UNIT	APPROX QTY.	UNIT PRICE	TOTAL AMOUNT	UNIT PRICE	TOTAL AMOUNT	UNIT PRICE	TOTAL AMOUNT
	ITEM NO.	CODE NO.									
<b>BASE BID UNIT PRICE SCHEDULE</b>											
20	506	6020	CONSTRUCTION EXITS (INSTALL) (TY 1)	SY	156	\$10.50	\$1,638.00	\$24.00	\$3,744.00	\$30.22	\$4,714.32
21	506	6024	CONSTRUCTION EXITS (REMOVE)	SY	156	\$6.00	\$936.00	\$8.00	\$1,248.00	\$9.20	\$1,435.20
22	506	6038	TEMP SEDMT CONT FENCE (INSTALL)	LF	1,829	\$3.50	\$6,401.50	\$4.00	\$7,316.00	\$4.02	\$7,352.58
23	506	6039	TEMP SEDMT CONT FENCE (REMOVE)	LF	1,829	\$1.50	\$2,743.50	\$3.00	\$5,487.00	\$1.20	\$2,194.80
24	528	6001	COLORED TEXTURED CONC (4")	SY	88	\$85.00	\$7,480.00	\$118.00	\$10,384.00	\$81.82	\$7,200.16
25	529	6007	CONC CURB & GUTTER (TY I)	LF	132	\$27.00	\$3,564.00	\$28.00	\$3,696.00	\$23.42	\$3,091.44
26	529	6008	CONC CURB & GUTTER (TY II)	LF	474	\$16.50	\$7,821.00	\$26.00	\$12,324.00	\$23.42	\$11,101.08
27	529	6036	CONCRETE CURB (SPECIAL)	LF	4,336	\$9.00	\$39,024.00	\$20.00	\$86,720.00	\$23.42	\$101,549.12
28	530	6004	DRIVEWAYS (CONC)	SY	217	\$56.22	\$12,199.74	\$117.00	\$25,389.00	\$72.00	\$15,624.00
29	531	6001	CONC SIDEWALKS (4")	SY	308	\$40.00	\$12,320.00	\$70.00	\$21,560.00	\$48.00	\$14,784.00
30	531	6004	CURB RAMPS (TY 1)	EA	3	\$1,810.00	\$5,430.00	\$1,500.00	\$4,500.00	\$1,963.56	\$5,890.68
31	531	6010	CURB RAMPS (TY 7)	EA	9	\$1,870.00	\$16,830.00	\$1,600.00	\$14,400.00	\$1,878.62	\$16,907.58
32	531	6034	CURB RAMPS (TY 7)(MOD)	EA	4	\$1,950.00	\$7,800.00	\$1,900.00	\$7,600.00	\$1,447.20	\$5,788.80
33	540	6001	MTL W-BEAM GD FEN (TIM POST)	LF	7	\$237.16	\$1,660.12	\$200.00	\$1,400.00	\$33.60	\$235.20
34	540	6014	SHORT RADIUS	LF	7	\$72.60	\$508.20	\$200.00	\$1,400.00	\$186.06	\$1,302.42
35	540	6015	DRIVEWAY TERMINAL ANCHOR SECTION	EA	2	\$1,095.81	\$2,191.62	\$2,000.00	\$4,000.00	\$1,318.67	\$2,637.34
36	542	6001	REMOVE METAL BEAM GUARD FENCE	LF	40	\$20.62	\$824.80	\$13.00	\$520.00	\$3.47	\$138.80
37	618	6023	CONDT (PVC) (SCH 40) (2")	LF	750	\$31.46	\$23,595.00	\$31.00	\$23,250.00	\$30.59	\$22,942.50
38	618	6024	CONDT (PVC) (SCH 40) (2") (BORE)	LF	120	\$37.51	\$4,501.20	\$37.25	\$4,470.00	\$37.20	\$4,464.00



## CITY OF EL PASO BID TABULATION FORM



**BID TITLE: YSLETA MIDDLE SCHOOL RTS** **BID NO: 2022--0271**  
**BID DATE: MAY 18, 2022** **DEPARTMENT: CAPITAL IMPROVEMENT**

					Allen Concrete, LLC El Paso, TX BIDDER 1 OF 4		Del Mar Contracting, Inc. El Paso, TX BIDDER 2 OF 4		Globe Builders, Inc. El Paso, TX BIDDER 3 OF 4		
NO.	ITEM-CODE		BRIEF DESCRIPTION OF ITEM	UNIT	APPROX QTY.	UNIT PRICE	TOTAL AMOUNT	UNIT PRICE	TOTAL AMOUNT	UNIT PRICE	TOTAL AMOUNT
	ITEM NO.	CODE NO.									
<b>BASE BID UNIT PRICE SCHEDULE</b>											
39	620	6008	ELEC CONDR (NO.8) INSULATED	LF	2,232	\$3.71	\$8,280.72	\$3.70	\$8,258.40	\$3.68	\$8,213.76
40	624	6001	GROUND BOX TY A (122311)	EA	4	\$1,996.50	\$7,986.00	\$2,000.00	\$8,000.00	\$1,980.00	\$7,920.00
41	628	6304	ELC SRV TY T 120/240 000(NS)GS(N)GC(O)	EA	1	\$9,559.00	\$9,559.00	\$9,500.00	\$9,500.00	\$9,480.00	\$9,480.00
42	636	6001	ALUMINUM SIGNS (TY A)	SF	58	\$54.45	\$3,158.10	\$54.00	\$3,132.00	\$54.00	\$3,132.00
43	644	6001	IN SM RD SN SUP&AM TY10BWG(1)SA(P)	EA	46	\$999.46	\$45,975.16	\$990.00	\$45,540.00	\$1,008.00	\$46,368.00
44	644	6076	REMOVE SM RD SN SUP&AM	EA	10	\$235.95	\$2,359.50	\$235.00	\$2,350.00	\$234.00	\$2,340.00
45	658	6016	INSTL DEL ASSM (D-SW)SZ (BRF)GF1 (BI)	EA	3	\$350.00	\$1,050.00	\$50.00	\$150.00	\$32.72	\$98.16
46	666	6006	REFL PAV MRK TY I (W)4"(DOT)(100MIL)	LF	34	\$6.29	\$213.86	\$6.25	\$212.50	\$6.24	\$212.16
47	666	6018	REFL PAV MRK TY I (W)6"(DOT)(100MIL)	LF	34	\$7.26	\$246.84	\$7.20	\$244.80	\$7.20	\$244.80
48	666	6036	REFL PAV MRK TY I (W)8"(SLD)(100MIL)	LF	171	\$3.57	\$610.47	\$3.50	\$598.50	\$3.54	\$605.34
49	666	6045	REFL PAV MRK TY I (W)18"(SLD)(100MIL)	LF	128	\$8.53	\$1,091.84	\$8.50	\$1,088.00	\$8.46	\$1,082.88
50	666	6048	REFL PAV MRK TY I (W)24"(SLD)(100MIL)	LF	378	\$9.68	\$3,659.04	\$9.60	\$3,628.80	\$9.60	\$3,628.80
51	666	6054	REFL PAV MRK TY I (W)(ARROW)(100MIL)	EA	2	\$157.30	\$314.60	\$156.00	\$312.00	\$156.00	\$312.00
52	666	6078	REFL PAV MRK TY I (W)(WORD)(100MIL)	EA	1	\$187.50	\$187.50	\$186.00	\$186.00	\$186.73	\$186.73
53	666	6105	REFL PAV MRK TY I (W)(BIKE ARW)(100MIL)	EA	6	\$229.90	\$1,379.40	\$230.00	\$1,380.00	\$228.00	\$1,368.00
54	666	6111	REFL PAV MRK TY I(W)(BIKE SYML)(100MIL)	EA	6	\$284.35	\$1,706.10	\$282.00	\$1,692.00	\$300.00	\$1,800.00
55	666	6207	REFL PAV MRK TY II (Y) 4" (SLD)	LF	275	\$0.42	\$115.50	\$0.50	\$137.50	\$0.42	\$115.50
56	666	6224	PAVEMENT SEALER 4"	LF	9,681	\$0.42	\$4,066.02	\$0.50	\$4,840.50	\$0.42	\$4,066.02
57	666	6225	PAVEMENT SEALER 6"	LF	7,223	\$0.67	\$4,839.41	\$0.65	\$4,694.95	\$0.42	\$3,033.66

240

Approved By: D.R  
Date: 6/2/2022



## CITY OF EL PASO BID TABULATION FORM



**BID TITLE: YSLETA MIDDLE SCHOOL RTS**  
**BID DATE: MAY 18, 2022**

**BID NO: 2022--0271**  
**DEPARTMENT: CAPITAL IMPROVEMENT**

					Allen Concrete, LLC El Paso, TX BIDDER 1 OF 4		Del Mar Contracting, Inc. El Paso, TX BIDDER 2 OF 4		Globe Builders, Inc. El Paso, TX BIDDER 3 OF 4		
NO.	ITEM-CODE		BRIEF DESCRIPTION OF ITEM	UNIT	APPROX QTY.	UNIT PRICE	TOTAL AMOUNT	UNIT PRICE	TOTAL AMOUNT	UNIT PRICE	TOTAL AMOUNT
	ITEM NO.	CODE NO.									
<b>BASE BID UNIT PRICE SCHEDULE</b>											
58	666	6226	PAVEMENT SEALER 8"	LF	68	\$0.85	\$57.80	\$1.00	\$68.00	\$0.84	\$57.12
59	666	6229	PAVEMENT SEALER 18"	LF	136	\$2.00	\$272.00	\$2.20	\$299.20	\$1.98	\$269.28
60	666	6230	PAVEMENT SEALER 24"	LF	207	\$2.66	\$550.62	\$3.00	\$621.00	\$2.64	\$546.48
61	666	6244	PAVEMENT SEALER (BIKE ARROW)	EA	6	\$48.40	\$290.40	\$50.00	\$300.00	\$48.00	\$288.00
62	666	6245	PAVEMENT SEALER (BIKE SYMBOL)	EA	6	\$60.50	\$363.00	\$75.00	\$450.00	\$60.00	\$360.00
63	666	ELP1	REFL PAV MRK TY I (W)4"(SLD)(100MIL)	LF	3,507	\$0.87	\$3,051.09	\$1.00	\$3,507.00	\$0.86	\$3,016.02
64	666	ELP2	REFL PAV MRK TY I (Y)4"(BRK)(100MIL)	LF	2,228	\$0.93	\$2,072.04	\$1.00	\$2,228.00	\$0.92	\$2,049.76
65	666	ELP3	REFL PAV MRK TY I (W)6"(SLD)(100MIL)	LF	7,189	\$1.39	\$9,992.71	\$1.40	\$10,064.60	\$1.38	\$9,920.82
66	666	ELP4	REFL PAV MRK TY I (Y)4"(SLD)(100MIL)	LF	8,742	\$0.87	\$7,605.54	\$1.00	\$8,742.00	\$0.86	\$7,518.12
67	677	6001	ELIM EXT PAV MRK & MRKS (4")	LF	3,912	\$0.91	\$3,559.92	\$1.00	\$3,912.00	\$0.90	\$3,520.80
68	677	6006	ELIM EXT PAV MRK & MRKS (18")	LF	103	\$4.84	\$498.52	\$5.00	\$515.00	\$4.80	\$494.40
69	677	6007	ELIM EXT PAV MRK & MRKS (24")	LF	91	\$7.26	\$660.66	\$7.20	\$655.20	\$7.20	\$655.20
70	678	6001	PAV SURF PREP FOR MRK (4")	LF	14,511	\$0.30	\$4,353.30	\$0.40	\$5,804.40	\$0.30	\$4,353.30
71	678	6002	PAV SURF PREP FOR MRK (6")	LF	7,223	\$0.48	\$3,467.04	\$0.50	\$3,611.50	\$0.48	\$3,467.04
72	678	6004	PAV SURF PREP FOR MRK (8")	LF	171	\$0.67	\$114.57	\$0.65	\$111.15	\$0.66	\$112.86
73	678	6007	PAV SURF PREP FOR MRK (18")	LF	128	\$1.63	\$208.64	\$1.70	\$217.60	\$1.62	\$207.36
74	678	6008	PAV SURF PREP FOR MRK (24")	LF	378	\$2.12	\$801.36	\$2.00	\$756.00	\$2.10	\$793.80
75	678	6009	PAV SURF PREP FOR MRK (ARROW)	EA	2	\$42.35	\$84.70	\$45.00	\$90.00	\$42.00	\$84.00
76	678	6016	PAV SURF PREP FOR MRK (WORD)	EA	1	\$42.35	\$42.35	\$45.00	\$45.00	\$42.00	\$42.00

241

Approved By: D.R  
Date: 6/2/2022



## CITY OF EL PASO BID TABULATION FORM



**BID TITLE: YSLETA MIDDLE SCHOOL RTS**  
**BID DATE: MAY 18, 2022**

**BID NO: 2022--0271**  
**DEPARTMENT: CAPITAL IMPROVEMENT**

					Allen Concrete, LLC  El Paso, TX BIDDER 1 OF 4		Del Mar Contracting, Inc.  El Paso, TX BIDDER 2 OF 4		Globe Builders, Inc.  El Paso, TX BIDDER 3 OF 4		
NO.	ITEM-CODE		BRIEF DESCRIPTION OF ITEM	UNIT	APPROX QTY.	UNIT PRICE	TOTAL AMOUNT	UNIT PRICE	TOTAL AMOUNT	UNIT PRICE	TOTAL AMOUNT
	ITEM NO.	CODE NO.									
<b>BASE BID UNIT PRICE SCHEDULE</b>											
77	678	6026	PAV SURF PREP FOR MRK (BIKE ARROW)	EA	6	\$42.35	\$254.10	\$45.00	\$270.00	\$42.00	\$252.00
78	678	6028	PAV SURF PREP FOR MRK (BIKE SYMBOL)	EA	6	\$42.35	\$254.10	\$45.00	\$270.00	\$42.00	\$252.00
79	ELP1	6001	ANTI-SLIP GREEN PAINT PED/BIKE PATH	SF	349	\$54.45	\$19,003.05	\$55.00	\$19,195.00	\$54.00	\$18,846.00
80	6185	6005	TMA (MOBILE OPERATION)	DAY	20	\$450.00	\$9,000.00	\$200.00	\$4,000.00	\$354.00	\$7,080.00
81	680	6001	INSTALL HWY TRF SIG (FLASH BEACON)	EA	2	\$11,936.65	\$23,873.30	\$12,000.00	\$24,000.00	\$11,838.00	\$23,676.00
82	682	6003	VEH SIG SEC (12")LED(YEL)	EA	10	\$635.25	\$6,352.50	\$630.00	\$6,300.00	\$630.00	\$6,300.00
83	686	6025	INS TRF SIG PL AM (S)1 ARM(24')	EA	2	\$13,305.16	\$26,610.32	\$13,200.00	\$26,400.00	\$13,194.78	\$26,389.56
84	7114	6001	WATER FILLED BARRIER (350)(TL-3)	LF	220	\$26.00	\$5,720.00	\$150.00	\$33,000.00	\$129.82	\$28,560.40
<b>SUM TOTAL BASE BID I: Items 1-84</b>						\$625,384.55		\$787,343.60		\$826,828.75	
						Contractor's Price: \$625,384.60					
<b>AMENDMENT ACKNOWLEDGED</b>						Yes		Yes		Yes	
<b>BID BOND SUBMITTED</b>						Yes		Yes		Yes	



## CITY OF EL PASO BID TABULATION FORM



**BID TITLE: YSLETA MIDDLE SCHOOL RTS**  
**BID DATE: MAY 18, 2022**

**BID NO: 2022--0271**  
**DEPARTMENT: CAPITAL IMPROVEMENT**

					Horizone Construction 1 Ltd. El Paso, TX BIDDER 4 OF 4						
NO.	ITEM-CODE		BRIEF DESCRIPTION OF ITEM	UNIT	APPROX QTY.	UNIT PRICE	TOTAL AMOUNT	UNIT PRICE	TOTAL AMOUNT	UNIT PRICE	TOTAL AMOUNT
	ITEM NO.	CODE NO.									
<b>BASE BID UNIT PRICE SCHEDULE</b>											
1	100	6001	PREPARING ROW	AC	1	\$24,980.84	\$24,980.84				
2	104	6017	REMOVING CONC (DRIVEWAYS)	SY	156	\$7.67	\$1,196.52				
3	104	6029	REMOVING CONC (CURB OR CURB & GUTTER)	LF	455	\$7.49	\$3,407.95				
4	104	6036	REMOVING CONC (SIDEWALK OR RAMP)	SY	313	\$14.23	\$4,453.99				
5	105	6015	REMOVING STAB BASE & ASPH PAV (8"-10")	SY	492	\$12.33	\$6,066.36				
6	110	6001	EXCAVATION (ROADWAY)	CY	437	\$12.18	\$5,322.66				
7	132	6002	EMBANKMENT (FINAL)(DENS CONT)(TY A)	CY	1,805	\$5.75	\$10,378.75				
8	192	6017	VEGETATION BARRIER	SY	219	\$4.95	\$1,084.05				
9	1002	6029	LANDSCAPE AMENITY (BOULDER)	EA	1	\$815.85	\$815.85				
10	1005	6001	LOOSE AGGR FOR GROUNDCOVER (TYPE I)	CY	19	\$149.41	\$2,838.79				
11	247	ELP1	FL BS (CMP IN PLACE) (TY A GR 1-2) (4")	SY	2,308	\$6.55	\$15,117.40				
12	310	6005	PRIME COAT (AE-P)	GAL	491	\$9.08	\$4,458.28				
13	3076	6040	D-GR HMA TY-D PG70-22	TON	294	\$87.12	\$25,613.28				
14	401	6001	FLOWABLE BACKFILL	CY	35	\$284.11	\$9,943.85				
15	416	6031	DRILL SHAFT (TRF SIG POLE) (30 IN)	LF	22	\$625.66	\$13,764.52				
16	465	ELP1	DROP INLET GRATE AND FRAME	EA	3	\$4,839.95	\$14,519.85				
17	466	6003	HEADWALL (CH - FW - 0) (DIA= 18 IN)	EA	1	\$8,456.76	\$8,456.76				
18	500	6001	MOBILIZATION	LS	1	\$8,000.08	\$8,000.08				
19	502	6001	BARRICADES, SIGNS AND TRAFFIC HANDLING	MO	6	\$15,122.93	\$90,737.58				



## CITY OF EL PASO BID TABULATION FORM



**BID TITLE: YSLETA MIDDLE SCHOOL RTS** **BID NO: 2022--0271**  
**BID DATE: MAY 18, 2022** **DEPARTMENT: CAPITAL IMPROVEMENT**

					Horizone Construction 1 Ltd. El Paso, TX BIDDER 4 OF 4						
NO.	ITEM-CODE		BRIEF DESCRIPTION OF ITEM	UNIT	APPROX QTY.	UNIT PRICE	TOTAL AMOUNT	UNIT PRICE	TOTAL AMOUNT	UNIT PRICE	TOTAL AMOUNT
	ITEM NO.	CODE NO.									
<b>BASE BID UNIT PRICE SCHEDULE</b>											
20	506	6020	CONSTRUCTION EXITS (INSTALL) (TY 1)	SY	156	\$52.05	\$8,119.80				
21	506	6024	CONSTRUCTION EXITS (REMOVE)	SY	156	\$9.75	\$1,521.00				
22	506	6038	TEMP SEDMT CONT FENCE (INSTALL)	LF	1,829	\$3.25	\$5,944.25				
23	506	6039	TEMP SEDMT CONT FENCE (REMOVE)	LF	1,829	\$1.11	\$2,030.19				
24	528	6001	COLORED TEXTURED CONC (4")	SY	88	\$98.16	\$8,638.08				
25	529	6007	CONC CURB & GUTTER (TY I)	LF	132	\$27.60	\$3,643.20				
26	529	6008	CONC CURB & GUTTER (TY II)	LF	474	\$19.13	\$9,067.62				
27	529	6036	CONCRETE CURB (SPECIAL)	LF	4,336	\$15.16	\$65,733.76				
28	530	6004	DRIVEWAYS (CONC)	SY	217	\$69.22	\$15,020.74				
29	531	6001	CONC SIDEWALKS (4")	SY	308	\$56.33	\$17,349.64				
30	531	6004	CURB RAMPS (TY 1)	EA	3	\$1,710.48	\$5,131.44				
31	531	6010	CURB RAMPS (TY 7)	EA	9	\$2,025.01	\$18,225.09				
32	531	6034	CURB RAMPS (TY 7)(MOD)	EA	4	\$1,820.71	\$7,282.84				
33	540	6001	MTL W-BEAM GD FEN (TIM POST)	LF	7	\$445.16	\$3,116.12				
34	540	6014	SHORT RADIUS	LF	7	\$207.79	\$1,454.53				
35	540	6015	DRIVEWAY TERMINAL ANCHOR SECTION	EA	2	\$1,224.61	\$2,449.22				
36	542	6001	REMOVE METAL BEAM GUARD FENCE	LF	40	\$43.08	\$1,723.20				
37	618	6023	CONDT (PVC) (SCH 40) (2")	LF	750	\$30.84	\$23,130.00				
38	618	6024	CONDT (PVC) (SCH 40) (2") (BORE)	LF	120	\$37.51	\$4,501.20				





## CITY OF EL PASO BID TABULATION FORM



**BID TITLE: YSLETA MIDDLE SCHOOL RTS**  
**BID DATE: MAY 18, 2022**

**BID NO: 2022--0271**  
**DEPARTMENT: CAPITAL IMPROVEMENT**

					Horizone Construction 1 Ltd. El Paso, TX BIDDER 4 OF 4						
NO.	ITEM-CODE		BRIEF DESCRIPTION OF ITEM	UNIT	APPROX QTY.	UNIT PRICE	TOTAL AMOUNT	UNIT PRICE	TOTAL AMOUNT	UNIT PRICE	TOTAL AMOUNT
	ITEM NO.	CODE NO.									
<b>BASE BID UNIT PRICE SCHEDULE</b>											
39	620	6008	ELEC CONDR (NO.8) INSULATED	LF	2,232	\$3.72	\$8,303.04				
40	624	6001	GROUND BOX TY A (122311)	EA	4	\$1,996.52	\$7,986.08				
41	628	6304	ELC SRV TY T 120/240 000(NS)GS(N)GC(O)	EA	1	\$9,559.10	\$9,559.10				
42	636	6001	ALUMINUM SIGNS (TY A)	SF	58	\$54.45	\$3,158.10				
43	644	6001	IN SM RD SN SUP&AM TY10BWG(1)SA(P)	EA	46	\$999.47	\$45,975.62				
44	644	6076	REMOVE SM RD SN SUP&AM	EA	10	\$235.95	\$2,359.50				
45	658	6016	INSTL DEL ASSM (D-SW)SZ (BRF)GF1 (BI)	EA	3	\$605.01	\$1,815.03				
46	666	6006	REFL PAV MRK TY I (W)4"(DOT)(100MIL)	LF	34	\$2.73	\$92.82				
47	666	6018	REFL PAV MRK TY I (W)6"(DOT)(100MIL)	LF	34	\$3.03	\$103.02				
48	666	6036	REFL PAV MRK TY I (W)8"(SLD)(100MIL)	LF	171	\$3.63	\$620.73				
49	666	6045	REFL PAV MRK TY I (W)18"(SLD)(100MIL)	LF	128	\$4.42	\$565.76				
50	666	6048	REFL PAV MRK TY I (W)24"(SLD)(100MIL)	LF	378	\$5.32	\$2,010.96				
51	666	6054	REFL PAV MRK TY I (W)(ARROW)(100MIL)	EA	2	\$580.80	\$1,161.60				
52	666	6078	REFL PAV MRK TY I (W)(WORD)(100MIL)	EA	1	\$1,210.01	\$1,210.01				
53	666	6105	REFL PAV MRK TY I (W)(BIKE ARW)(100MIL)	EA	6	\$346.06	\$2,076.36				
54	666	6111	REFL PAV MRK TY I(W)(BIKE SYML)(100MIL)	EA	6	\$726.01	\$4,356.06				
55	666	6207	REFL PAV MRK TY II (Y) 4" (SLD)	LF	275	\$3.63	\$998.25				
56	666	6224	PAVEMENT SEALER 4"	LF	9,681	\$0.70	\$6,776.70				
57	666	6225	PAVEMENT SEALER 6"	LF	7,223	\$0.63	\$4,550.49				



## CITY OF EL PASO BID TABULATION FORM



**BID TITLE: YSLETA MIDDLE SCHOOL RTS**  
**BID DATE: MAY 18, 2022**

**BID NO: 2022--0271**  
**DEPARTMENT: CAPITAL IMPROVEMENT**

					Horizone Construction 1 Ltd. El Paso, TX BIDDER 4 OF 4						
NO.	ITEM-CODE		BRIEF DESCRIPTION OF ITEM	UNIT	APPROX QTY.	UNIT PRICE	TOTAL AMOUNT	UNIT PRICE	TOTAL AMOUNT	UNIT PRICE	TOTAL AMOUNT
	ITEM NO.	CODE NO.									
<b>BASE BID UNIT PRICE SCHEDULE</b>											
58	666	6226	PAVEMENT SEALER 8"	LF	68	\$2.42	\$164.56				
59	666	6229	PAVEMENT SEALER 18"	LF	136	\$3.03	\$412.08				
60	666	6230	PAVEMENT SEALER 24"	LF	207	\$4.18	\$865.26				
61	666	6244	PAVEMENT SEALER (BIKE ARROW)	EA	6	\$212.96	\$1,277.76				
62	666	6245	PAVEMENT SEALER (BIKE SYMBOL)	EA	6	\$217.80	\$1,306.80				
63	666	ELP1	REFL PAV MRK TY I (W)4"(SLD)(100MIL)	LF	3,507	\$2.73	\$9,574.11				
64	666	ELP2	REFL PAV MRK TY I (Y)4"(BRK)(100MIL)	LF	2,228	\$2.73	\$6,082.44				
65	666	ELP3	REFL PAV MRK TY I (W)6"(SLD)(100MIL)	LF	7,189	\$3.03	\$21,782.67				
66	666	ELP4	REFL PAV MRK TY I (Y)4"(SLD)(100MIL)	LF	8,742	\$2.73	\$23,865.66				
67	677	6001	ELIM EXT PAV MRK & MRKS (4")	LF	3,912	\$2.12	\$8,293.44				
68	677	6006	ELIM EXT PAV MRK & MRKS (18")	LF	103	\$2.12	\$218.36				
69	677	6007	ELIM EXT PAV MRK & MRKS (24")	LF	91	\$2.12	\$192.92				
70	678	6001	PAV SURF PREP FOR MRK (4")	LF	14,511	\$0.12	\$1,741.32				
71	678	6002	PAV SURF PREP FOR MRK (6")	LF	7,223	\$0.14	\$1,011.22				
72	678	6004	PAV SURF PREP FOR MRK (8")	LF	171	\$0.22	\$37.62				
73	678	6007	PAV SURF PREP FOR MRK (18")	LF	128	\$0.46	\$58.88				
74	678	6008	PAV SURF PREP FOR MRK (24")	LF	378	\$0.51	\$192.78				
75	678	6009	PAV SURF PREP FOR MRK (ARROW)	EA	2	\$36.30	\$72.60				
76	678	6016	PAV SURF PREP FOR MRK (WORD)	EA	1	\$70.18	\$70.18				



## CITY OF EL PASO BID TABULATION FORM



**BID TITLE: YSLETA MIDDLE SCHOOL RTS** **BID NO: 2022--0271**  
**BID DATE: MAY 18, 2022** **DEPARTMENT: CAPITAL IMPROVEMENT**

					Horizone Construction 1 Ltd. El Paso, TX BIDDER 4 OF 4						
NO.	ITEM-CODE		BRIEF DESCRIPTION OF ITEM	UNIT	APPROX QTY.	UNIT PRICE	TOTAL AMOUNT	UNIT PRICE	TOTAL AMOUNT	UNIT PRICE	TOTAL AMOUNT
	ITEM NO.	CODE NO.									
<b>BASE BID UNIT PRICE SCHEDULE</b>											
77	678	6026	PAV SURF PREP FOR MRK (BIKE ARROW)	EA	6	\$45.98	\$275.88				
78	678	6028	PAV SURF PREP FOR MRK (BIKE SYMBOL)	EA	6	\$48.40	\$290.40				
79	ELP1	6001	ANTI-SLIP GREEN PAINT PED/BIKE PATH	SF	349	\$15.47	\$5,399.03				
80	6185	6005	TMA (MOBILE OPERATION)	DAY	20	\$756.26	\$15,125.20				
81	680	6001	INSTALL HWY TRF SIG (FLASH BEACON)	EA	2	\$2,256.67	\$4,513.34				
82	682	6003	VEH SIG SEC (12")LED(YEL)	EA	10	\$635.26	\$6,352.60				
83	686	6025	INS TRF SIG PL AM (S)1 ARM(24')	EA	2	\$10,884.06	\$21,768.12				
84	7114	6001	WATER FILLED BARRIER (350)(TL-3)	LF	220	\$42.35	\$9,317.00				
<b>SUM TOTAL BASE BID I: Items 1-84</b>						<b>\$699,180.74</b>					
<b>AMENDMENT ACKNOWLEDGED</b>						<b>Yes</b>					
<b>BID BOND SUBMITTED</b>						<b>Yes</b>					

## 2022-0271 Ysleta Middle School RTS

## Views List

No.	COMPANY	NAME
1	123 Builders Co	Ibrahim, Mark
2	915 Sweep And Go llc	Duran, Rudy
3	Abescape	Gallegos, Mari
4	Access Communication	Dittmar, Mark
5	Allen Concrete Inc.	Magdaleno, Jesus
6	AMTEK	Rugh, John
7	Bella Luna Engineeri	Luna, Larry
8	Black Stallion Contr	Luna, Hector
9	Blueline Constructio	Reyes, Arturo
10	Border Demolition An	Acosta, David
11	CEA Group	Concha, David
12	Civil Associates, In	Hernandez, Eddie
13	ConstructConnect	STINSON, MORGAN
14	Construction Reporte	Wood, Jane
15	Dannenbaum Engineeri	Villalobos, Silverio
16	Dantex Construction	Pelech, Keeley
17	Deltek	Management, Source
18	Direx Construction,	Hudson, Brad
19	Dodge Data	Peggy, Koehn
20	Dodge Data And Analy	Loganathan, Jayalakshmi
21	DRS Rock Materials,	Soto, Daniel
22	EMJ Construction	Ross, Chris
23	Enotsyek	Dominguez, Luis
24	EPHCC	Mireles, Maria
25	eRepublic, Inc.	Lamoreaux, Mary
26	GCC Sun City Materia	Rivas, Fernando
27	Globe Builders	Castillo, Marcos
28	Globe Builders, LLC	Banks, Archie
29	Gracen Eng. And Cons	Sambrano, Michael
30	HAWK	Jorge, Ojeda
31	HB Construction	Mulligan, Matthew
32	Herreras Constructio	Herrera, Miguel
33	HNTB	Aguilar, Omar
34	HNTB Corporation	Vrahnos, Gavin
35	Horizone Const. 1 LT	De Stefano, Luis Rene
36	HUB	Gilcrease, Paul
37	i- Sourcing Technolo	Balai, Rakesh
38	Jace Contracting Ser	Crossland, Randal
39	Jerry Priester	Priester, Jerry
40	Jobe Materials	Favela, Melissa
41	Lara Construction	Mario, Lara
42	LDCM Solutions, LLC	De La Rosa, Andrew
43	Lobo Distribution LL	Wolfe, Perry
44	Lomeli and sons Land	Gonzalez, Ruben
45	Martinez Brothers Co	mota, pablo
46	Medlock Commercial C	Medlock, Steve

2022-0271 Ysleta Middle School RTS  
Views List

47	Mid-America Golf And	Grego, Kirk
48	Mr.	Ortiz, Cano
49	Pacific Inc	Doe, John
50	Perikin Enterprises	Silva, Luis
51	Prime Vendor Inc.	Jones, Kim
52	RDZ BUILD	Rodriguez, Manny
53	Smartprocure	Bjornsson, Ron
54	SPARTAN CONSTRUCTION	ALLEN, STEVE
55	Straight Edge Contra	Jesus, Mesta
56	The PlanIt Room	Hernandez, Cecilia
57	tierra firme const i	ruiz jr, abraham g
58	Tri-State Electric,	Motta, Alejandro
59	VEMAC	Maynez, Alejandra
60	Vertex Contractors,	Ruiz, Erika
61	Visual Infomedia	N, Sivakumar
62	Vitual Builders Exch	Olguin, Jeannette
63	Wayne Enterprises	Austin, Fork
64	ZTEX Construction I	Royo, Joaquin
65		Watson, Frank
66		Lechuga, Alfredo
67		Banquil, Lovely
68		Maldonado, Mariana
69		Morales, Victor



---

**File #: 22-953, Version: 1**

---

**CITY OF EL PASO, TEXAS  
LEGISTAR AGENDA ITEM SUMMARY FORM**

**DISTRICT, DEPARTMENT, CONTACT INFORMATION:**

*Please choose District and Department from drop down menu. Please post exactly as example below.  
No Title's, No emails. Please use ARIAL 10 Font.*

**All Districts**

El Paso Water, Arturo Duran, (915) 594-5549

**AGENDA LANGUAGE:**

*This is the language that will be posted to the agenda. Please use ARIAL 11 Font.*

An Ordinance authorizing the issuance of City of El Paso, Texas, Water and Sewer Revenue Bonds, in one or more series, in an aggregate amount not to exceed \$441,000,000 for System improvements and to refund certain obligations issued for System improvements; and resolving matters which are necessary to effect such issuance, including the delegation of matters relating to the sale and issuance of the bonds to an authorized City officer or employee within certain specified parameters.

**CITY OF EL PASO, TEXAS  
AGENDA ITEM DEPARTMENT HEAD'S SUMMARY FORM**

**DEPARTMENT:** El Paso Water Utilities Public Service Board

**AGENDA DATE:** Introduction and Public Hearing- August 2, 2022

**CONTACT PERSON/PHONE:** Art Duran, El Paso Water Utilities Chief Financial Officer  
(915) 594-5549

**DISTRICT(S) AFFECTED:** All Districts

**SUBJECT:** APPROVE the following Ordinance

An Ordinance authorizing the issuance of City of El Paso, Texas, Water and Sewer Revenue Bonds, in one or more series, in an aggregate amount not to exceed \$441,000,000 for System improvements and to refund certain obligations issued for System improvements; and resolving matters which are necessary to effect such issuance, including the delegation of matters relating to the sale and issuance of the bonds to an authorized City officer or employee within certain specified parameters. (All Districts) [Arturo Duran, El Paso Water (915) 594-5549][Public Hearing Date: August 2, 2022]

**BACKGROUND / DISCUSSION:**

EPWater is requesting the City Council of the City of El Paso to authorize the issuance of up to \$441,000,000 of City of El Paso, Texas, Water and Sewer Revenue Bonds in one or more series.

EPWater finds that it is in the best interest of the ratepayers to pursue this financing.

**PRIOR COUNCIL ACTION:**

**Has the Council previously considered this item or a closely related one?**

Yes, on March 29, 2022, City Council approved the issuance of \$356,325,000 of City of El Paso, Texas Water and Sewer System Revenue Improvement and Refunding Bonds, Series 2022.”

**AMOUNT AND SOURCE OF FUNDING:**

This item will be funded through the sale of City of El Paso, Texas Water and Sewer System Revenue Bonds, in one or more series.

**BOARD / COMMISSION ACTION:**

The El Paso Water Utilities Public Service Board approved a Resolution on July 14, 2022, the City Council authorize the issuance of up to \$441,000,000 of City of El Paso, Texas Water and Sewer Revenue Improvement and/or Refunding Bonds to pay off up to \$240,000,000 in commercial paper notes, fund approximately \$193,154,000 of Capital Improvement Program Projects approved for Fiscal Year 2022-2023, and approximately \$7,846,000 to fund related transaction costs, provided that certain parameters are met.

**AFTER EXECUTION OF ALL DOCUMENTS, PLEASE CONTACT ART DURAN TO PICK UP THE DOCUMENTS AT (915) 594-5549. THANK YOU.**



**TO:** Tomás González, City Manager, The City of El Paso, Texas

**FROM:** Art Duran, Utility Chief Financial Officer  
El Paso Water Utilities Public Service Board

**DATE:** July 22, 2022

**SUBJECT:** Request to place the following items on **Regular City Council Agenda for August 2, 2022:**

**Item (1). Ordinance Introduction and Public Hearing: City of El Paso, Texas, Water and Sewer Revenue Bonds, in one or more series.**

**Item (2). Ordinance Introduction and Public Hearing: City of El Paso, Texas, Municipal Drainage Utility System Revenue Refunding Bonds, Series 2023.**

*Agenda Posting Language for Item 1:*

An Ordinance authorizing the issuance of City of El Paso, Texas, Water and Sewer Revenue Bonds, in one or more series, in an aggregate amount not to exceed \$441,000,000 for System improvements and to refund certain obligations issued for System improvements; and resolving matters which are necessary to effect such issuance, including the delegation of matters relating to the sale and issuance of the bonds to an authorized City officer or employee within certain specified parameters. (All Districts) [Arturo Duran, El Paso Water (915) 594-5549][Public Hearing Date: August 2, 2022]

*Agenda Posting Language for Item 2:*

An Ordinance authorizing the issuance of “City of El Paso, Texas, Municipal Drainage Utility System Revenue Refunding Bonds, Series 2023” in an amount not to exceed \$25,330,000 to refund certain previously issued obligations of the City; and resolving matters which are necessary to effect such issuance, including the delegation of matters relating to the sale and issuance of the bonds to an authorized City officer or employee within certain specified parameters. (All Districts) [Arturo Duran, El Paso Water (915) 594-5549][Public Hearing Date: August 2, 2022]

\*\*\*\*\*

These two agenda items requested to be posted on the City Council’s August 2, 2022, City Council Agenda, is pursuant to separate Resolutions of El Paso Water Utilities Public Service Board (PSB) approved at the PSB’s July 13, 2022, meeting, requesting the following:

- (1) Resolution requesting the City Council to authorize the issuance of up to \$25,330,000 of City of El Paso, Texas Municipal Drainage Utility System Revenue Refunding Bonds, to pay off \$25,000,000 in Direct Funded Revolving Loan Notes and fund interest and related transaction costs, provided that certain parameters are met.



(2) Resolution requesting that the City Council authorize the issuance of up to \$441,000,000 of City of El Paso, Texas Water and Sewer Revenue Improvement and/or Refunding Bonds to pay off up to \$240,000,000 in commercial paper notes, fund approximately \$193,154,000 of Capital Improvement Program Projects approved for Fiscal Year 2022-2023, and approximately \$7,846,000 to fund related transaction costs, provided that certain parameters are met.

If there are any questions, please call me directly at (915) 594-5549 or email me at [ADuran@epwater.org](mailto:ADuran@epwater.org) or contact General Counsel, Daniel Ortiz at (915) 594-5607.

Thank you for your attention to this matter.

Attachments: Department Head Summary Forms  
PSB July 13, 2022, Resolutions  
Proposed City Council Ordinances  
City Council Presentations

cc: The Honorable Mayor Oscar Leeser (email)  
Estrella Escobar, Chief of Staff, Mayor (email)  
Robert Cortinas, Deputy City Manager and CFO (email)  
  
Karla Nieman, City Attorney (email)  
Juan Gonzalez, Senior Assistant City Attorney (email)  
Laura D. Prine, City Clerk (email)

John Balliew, P.E., President/CEO EPWU-PSB (email)  
Claudia Duran, Executive Assistant to President/CEO (email)  
Marcela Navarete, C.P.A, Vice President-Strategic Financial &  
Management Services (email)  
  
Daniel Ortiz, General Counsel (email)  
Paul Braden, Norton, Rose, Fulbright, Bond Counsel (email)  
Maria Urbina, HTS (email)

## RESOLUTION

A RESOLUTION REQUESTING THAT THE EL PASO CITY COUNCIL AUTHORIZE THE ISSUANCE OF UP TO \$441,000,000 OF CITY OF EL PASO, TEXAS, WATER AND SEWER REVENUE IMPROVEMENT AND/OR REFUNDING BONDS TO PAY OFF UP TO \$240,000,000 IN COMMERCIAL PAPER NOTES, FUND APPROXIMATELY \$193,154,000 OF CAPITAL IMPROVEMENT PROGRAM PROJECTS APPROVED FOR FISCAL YEAR 2022-2023, AND APPROXIMATELY \$7,846,000 TO FUND RELATED TRANSACTION COSTS, PROVIDED THAT CERTAIN PARAMETERS ARE MET.

**WHEREAS**, the El Paso Water Utilities Public Service Board (“Board”), was established on May 22, 1952, by Ordinance No. 752 of the City of El Paso for the purpose of the Board having complete authority and control of the management and operation of the water and wastewater system (the “System”); and,

**WHEREAS**, there have been filed with the City Council one or more resolutions adopted and approved by the Public Service Board requesting the City Council to approve the issuance and sale of the City’s revenue bonds for System purposes; and,

**WHEREAS**, the Board hereby finds and determines that it is in the best interest of the City and the System to refund up to \$240,000,000 of the City’s System revenue commercial paper notes (the “Refunded Commercial Paper Notes”) , which are currently outstanding and are authorized to be issued from time to time in an aggregate principal amount not to exceed \$80,000,000, for the purposes of making such debt long-term fixed rate debt of the City; and,

**WHEREAS**, in addition to and/or in combination with the revenue bonds issued to refund the Refunded Commercial Paper Notes, the Board hereby finds and determines that is in the best interest of System to fund approximately \$193,154,000 of El Paso Water’s Water and Wastewater approved Capital Improvement Program for Fiscal Year 2022-2023; and,

**WHEREAS**, the Board requests the El Paso City Council to authorize the issuance of up to \$440,000,000 of City of El Paso, Texas, Water and Sewer Revenue Improvement and/or Refunding Bonds which includes related transaction costs.

**NOW, THEREFORE, BE IT RESOLVED BY THE PUBLIC SERVICE BOARD OF THE CITY OF EL PASO, TEXAS:**

**Section 1.** That the findings and recitations set out in the preamble to this Resolution are found to be true and correct and are hereby adopted by the El Paso Water Utilities Public Service Board and made a part of this Resolution for all purposes.

**Section 2.** That El Paso Water Utilities Public Service Board hereby requests the El Paso City Council to authorize the issuance of up to \$441,000,000 of City of El Paso, Texas, Water and Sewer Revenue Improvement and/or Refunding Bonds, (i) to pay off up to \$240,000,000 in commercial paper notes, (ii) to fund approximately \$193,154,000 of El Paso Water’s Water and Wastewater approved Capital Improvement Program for Fiscal Year 2022-2023, and (iii) to fund approximately \$7,846,000 of interest and related transaction costs, provided that certain pricing parameters as set forth in the City’s bond ordinance are met.

**PASSED AND APPROVED at the regular meeting of the Public Service Board, this 13th day of July, 2022, at which meeting a quorum was present and which was held in accordance with the provisions of Texas Government Code, Sections 551.001, et. seq.**

EL PASO WATER UTILITIES  
PUBLIC SERVICE BOARD

ATTEST:

  
\_\_\_\_\_  
Bryan Morris, Secretary/Treasurer

  
\_\_\_\_\_  
Kristina D. Mena, Chair

APPROVED AS TO CONTENT:

  
\_\_\_\_\_  
Arturo Duran  
Chief Financial Officer

APPROVED AS TO FORM:

  
\_\_\_\_\_  
Daniel Ortiz  
General Counsel

---

---

ORDINANCE NO. \_\_\_\_\_

AUTHORIZING THE ISSUANCE OF

CITY OF EL PASO, TEXAS,  
WATER AND SEWER REVENUE BONDS

Adopted: \_\_\_\_\_, 2022

TABLE OF CONTENTS

ARTICLE 1  
DEFINITIONS, FINDINGS AND INTERPRETATION

Section 1.01 Definitions..... 2  
Section 1.02 Findings..... 7  
Section 1.03 Table of Contents, Titles and Headings ..... 7  
Section 1.04 Interpretation..... 7

ARTICLE 2  
SECURITY FOR THE BONDS

Section 2.01 Security for the Bonds ..... 7  
Section 2.02 Limited Obligations ..... 7  
Section 2.03 Security Interest ..... 8

ARTICLE 3  
AUTHORIZATION; GENERAL TERMS AND PROVISIONS REGARDING THE BONDS

Section 3.01 Authorization ..... 8  
Section 3.02 Delegation of Authority to Pricing Officer ..... 8  
Section 3.03 Date, Denomination, Maturities, Numbers and Interest. .... 9  
Section 3.04 Medium, Method and Place of Payment. .... 10  
Section 3.05 Execution and Initial Registration ..... 11  
Section 3.06 Ownership..... 11  
Section 3.07 Registration, Transfer and Exchange..... 12  
Section 3.08 Cancellation and Authentication..... 13  
Section 3.09 Temporary Bonds..... 14  
Section 3.10 Replacement Bonds. .... 14  
Section 3.11 Book-Entry-Only System..... 15  
Section 3.12 Successor Securities Depository; Transfer Outside Book-Entry Only  
System..... 16  
Section 3.13 Payments to Cede & Co..... 16

ARTICLE 4  
REDEMPTION OF BONDS BEFORE MATURITY

Section 4.01 Limitation on Redemption ..... 16

ARTICLE 5  
PAYING AGENT/REGISTRAR

Section 5.01 Appointment of Initial Paying Agent/Registrar..... 16

TABLE OF CONTENTS  
(continued)

	<u>Page</u>
Section 5.02	Qualifications of Paying Agent/Registrar ..... 16
Section 5.03	Maintaining Paying Agent/Registrar. .... 17
Section 5.04	Termination of Paying Agent/Registrar..... 17
Section 5.05	Notice of Change of Paying Agent/Registrar to Owners..... 17
Section 5.06	Agreement of Paying Agent/Registrar to Perform Duties and Functions..... 17
Section 5.07	Delivery of Records to Successor ..... 17
 ARTICLE 6 FORM OF THE BONDS  	
Section 6.01	Form Generally. .... 17
Section 6.02	Form of the Bonds ..... 18
Section 6.03	CUSIP Registration..... 18
Section 6.04	Legal Opinion ..... 18
Section 6.05	Statement of Insurance..... 18
 ARTICLE 7 PUBLIC SERVICE BOARD  	
Section 7.01	Public Service Board..... 18
 ARTICLE 8 FUNDS; FLOW OF FUNDS  	
Section 8.01	Special Funds. .... 20
Section 8.02	Revenue Fund ..... 20
Section 8.03	Investment of Funds..... 22
Section 8.04	Contributions in Aid of Construction ..... 22
Section 8.05	Construction Fund..... 23
 ARTICLE 9 DEPOSIT OF PROCEEDS; CONTROL AND DELIVERY OF BONDS  	
Section 9.01	Deposit of Proceeds. .... 23
Section 9.02	Control and Delivery of Bonds. .... 23
 ARTICLE 10 PARTICULAR REPRESENTATIONS AND COVENANTS  	
Section 10.01	Insurance ..... 23
Section 10.02	Books and Records ..... 24
Section 10.03	Additional Covenants..... 24
Section 10.04	Covenants to Maintain Tax Exempt Status..... 26

TABLE OF CONTENTS  
(continued)

		<u>Page</u>
Section 10.05	Continuing Obligation .....	29
ARTICLE 11 DEFAULT AND REMEDIES		
Section 11.01	Remedies in Event of Default .....	29
Section 11.02	Remedies Not Exclusive .....	30
ARTICLE 12 DISCHARGE		
Section 12.01	Discharge .....	30
ARTICLE 13 SALE AND DELIVERY OF BONDS; OFFICIAL STATEMENT		
Section 13.01	Sale of Bonds-Official Statement. ....	31
ARTICLE 14 CONTINUING DISCLOSURE UNDERTAKING		
Section 14.01	Annual Reports. ....	32
Section 14.02	Notice of Certain Events .....	33
Section 14.03	Filings with the MSRB .....	34
Section 14.04	Limitations, Disclaimers and Amendments.....	34
ARTICLE 15 PAYMENT OF REFUNDED COMMERCIAL PAPER NOTES.		
Section 15.01	Payment of Refunded Commercial Paper Notes .....	35
Section 15.02	Escrow Agreement.....	35
ARTICLE 16 MISCELLANEOUS		
Section 16.01	Amendment to Ordinance .....	36
Section 16.02	Further Procedures .....	37
Section 16.03	Municipal Bond Insurance .....	38
Section 16.04	Effectiveness .....	38
Exhibit A	PAYING AGENT/REGISTRAR AGREEMENT	
Exhibit B	FORM OF BOND	

AN ORDINANCE AUTHORIZING THE ISSUANCE OF CITY OF EL PASO, TEXAS, WATER AND SEWER REVENUE BONDS, IN ONE OR MORE SERIES, IN AN AGGREGATE AMOUNT NOT TO EXCEED \$441,000,000 FOR SYSTEM IMPROVEMENTS AND TO REFUND CERTAIN OBLIGATIONS ISSUED FOR SYSTEM IMPROVEMENTS; AND RESOLVING MATTERS WHICH ARE NECESSARY TO EFFECT SUCH ISSUANCE, INCLUDING THE DELEGATION OF MATTERS RELATING TO THE SALE AND ISSUANCE OF THE BONDS TO AN AUTHORIZED CITY OFFICER OR EMPLOYEE WITHIN CERTAIN SPECIFIED PARAMETERS

WHEREAS, in accordance with the Constitution and the laws of the State of Texas, specifically Texas Government Code, Chapter 1502, as amended, the City of El Paso, Texas (the "City"), has previously issued waterworks and sewer system revenue bonds (the "Previously Issued Senior Lien Bonds") payable from and secured by a first and superior lien on and pledge of the net revenues of the City's combined waterworks and sewer system (the "System"); and

WHEREAS, there has been filed with the City Council one or more resolutions adopted and approved by the Public Service Board requesting the City Council to approve the issuance and sale of the City's revenue bonds for the purposes of (1) refunding certain outstanding obligations secured by revenues of the System; (2) constructing, acquiring, purchasing, renovating, enlarging, equipping, and improving System properties and facilities; and (3) paying the costs of issuing the Bonds as described in the Ordinance; and

WHEREAS, the City Council hereby finds and determines that it is in the best interest of the City and the System to refund certain of its System revenue commercial paper notes (the "Refunded Commercial Paper Notes"); and

WHEREAS, in combination with the revenue bonds issued to refund the Refunded Commercial Paper Notes, the City Council further finds and determines that additional revenue bonds should be issued and sold for the purpose of constructing, acquiring, purchasing, renovating, enlarging, equipping, and improving System properties and facilities; and

WHEREAS, the City by this Ordinance and in accordance with the provisions of Texas Government Code, Chapter 1207, as amended ("Chapter 1207") and Texas Government Code, Chapter 1371, as amended ("Chapter 1371"), is delegating to the Pricing Officer (hereinafter defined) the authority to establish the terms and details related to the issuance and sale of the bonds authorized by this Ordinance (the "Bonds") including: (i) the principal amount of the Refunded Commercial Paper Notes to be refunded, (ii) the form and designation of one or more series of Bonds; (iii) the principal amount of each series of the Bonds and the amount of the Bonds of each series to mature in each year; (iv) the dates, price, interest rates, interest payment dates, principal payment dates, and redemption features of each series of the Bonds; and (v) any other details relating to the issuance, sale, delivery, and/or exchange of the Bonds, all within certain specified parameters set forth herein; and

WHEREAS, the City Council hereby finds and determines that the refunding of the Refunded Commercial Paper Notes for the purposes of making such debt long-term fixed rate debt of the City and restructuring the debt payable from the revenues of the System is in the best interest



of the City, and the manner in which such refunding is being executed does not make it practicable to make the determinations otherwise required by Texas Government Code, Section 1207.008(a)(2), as amended; and

WHEREAS, in the ordinances authorizing the Previously Issued Senior Lien Bonds, the City reserved the right and option to issue, under certain conditions, “Additional Bonds” on a parity as to lien and right with such bonds; and

WHEREAS, a public hearing was held, following proper publication of notice thereof, before the City Council with respect to the adoption of this Ordinance; and

WHEREAS, the City Council has found and determined that the bonds herein authorized should be issued on a parity with its Previously Issued Senior Lien Bonds, for the purposes aforesaid, pursuant to this Ordinance and as permitted by the General Laws of the State of Texas, particularly Chapter 1207 and Chapter 1371; and

WHEREAS, the meeting at which this Ordinance is considered is open to the public as required by law, and the public notice of the time, place and purpose of such meeting was given as required by Texas Government Code, Chapter 551, as amended;

NOW, THEREFORE, BE IT ORDAINED BY THE CITY COUNCIL OF THE CITY OF EL PASO, TEXAS, THAT:

## ARTICLE 1

### DEFINITIONS, FINDINGS AND INTERPRETATION

Section 1.01 Definitions. Unless otherwise expressly provided or unless the context clearly requires otherwise, in this Ordinance, the following terms shall have the meanings specified below:

“Additional Bonds” means the additional revenue bonds permitted to be issued on a parity with the Bonds and the Previously Issued Senior Lien Bonds by Section 10.03(a) of this Ordinance.

“Board” or “Board of Trustees” means that certain board of trustees known as the “Public Service Board” heretofore established for the purpose of managing the System, and other water utilities of the City, as represented by the various persons appointed from time to time.

“Bond” means any of the Bonds.

“Bonds” means the City of El Paso, Texas, Water and Sewer Revenue Bonds, authorized to be issued by this Ordinance, and any additional or different series or designation specified in an applicable Pricing Certificate.

“Bond Counsel” means a firm of nationally recognized attorneys experienced in the issuance of bonds and acceptable to the City, initially Norton Rose Fulbright US LLP.

“Business Day” means any day other than a Saturday, Sunday or legal holiday or other day on which banking institutions in the city where the Designated Payment/Transfer Office of the Paying Agent/Registrar is located in the State of Texas are generally authorized or obligated by law or executive order to close.

“Chapter 1207” means Texas Government Code, Chapter 1207, as amended.

“Chapter 1371” means Texas Government Code, Chapter 1371, as amended.

“Chapter 1502” means Texas Government Code, Chapter 1502, as amended.

“City” means the City of El Paso, Texas, and with respect to those matters requiring action regarding the authority and control of management and operation of the System or the expenditure and application of the System’s revenues, “City” shall mean the Board acting on behalf of the City.

“City Council” means the governing body of the City of El Paso, Texas.

“Closing Date” means the date of the initial delivery of and payment for the Bonds.

“Code” means the Internal Revenue Code of 1986, as amended, including the regulations and published rulings thereunder.

“Construction Fund” means the fund by such name described in Section 8.05(a) hereof.

“Depository Bank” means any financial institution duly designated by the Board to serve as a depository for funds controlled by the Board.

“Designated Payment/Transfer Office” means (i) with respect to the initial Paying Agent/Registrar named herein, its designated office specified in the Pricing Certificate, or at such other location designated by the Paying Agent/Registrar and (ii) with respect to any successor Paying Agent/Registrar, the office of such successor designated and located as may be agreed upon by the City and such successor.

“DTC” means The Depository Trust Company of New York, New York, or any successor securities depository.

“DTC Participant” means brokers and dealers, banks, trust companies, clearing corporations and certain other organizations on whose behalf DTC was created to hold securities to facilitate the clearance and settlement of securities transactions among DTC Participants.

“Escrow Agreement” means any deposit or escrow agreement between the City and an escrow agent designated in the Pricing Certificate, which may include the issuing and paying agent for the Refunded Commercial Paper Notes, authorized in accordance with terms hereof, including Article 15.

“Financial Obligation” means a (a) debt obligation; (b) derivative instrument entered into in connection with, or pledged as security or a source of payment for, an existing or planned debt obligation; or (c) guarantee of a debt obligation or any such derivative instrument; provided that

“financial obligation” shall not include municipal securities as to which a final official statement (as defined in the Rule) has been provided to the MSRB consistent with the Rule.

“Government Obligations” unless otherwise provided in the Pricing Certificate, means (i) direct, noncallable obligations of the United States of America, including obligations the principal of and interest on which are unconditionally guaranteed by the United States of America, (ii) noncallable obligations of an agency or instrumentality of the United States, including obligations unconditionally guaranteed or insured by the agency or instrumentality and, on the date of their acquisition or purchase by the City, are rated as to investment quality by a nationally recognized investment rating firm not less than AAA or its equivalent, (iii) noncallable obligations of a state or an agency or a county, municipality, or other political subdivision of a state that have been refunded and that, on the date of their acquisition or purchase by the City, are rated as to investment quality by a nationally recognized investment rating firm not less than AAA or its equivalent and (iv) any other then authorized securities or obligations that may be used to defease obligations such as the Bonds under the then applicable laws of the State of Texas.

“Gross Revenues” means all of the revenues of every nature received through the operation of the System.

“Improvement Fund” means the fund by such name described in Section 8.01(a)(iv) hereof.

“Initial Bond” means the Initial Bond authorized by Section 3.04 of this Ordinance.

“Initial Date” means the date designated as the Initial Date in the Pricing Certificate.

“Interest and Sinking Fund” means the fund by that name described in Section 8.01(a)(ii) hereof.

“Interest Payment Date” means the date or dates on which interest on the principal of the Bonds is scheduled to be paid until their respective dates of maturity or prior redemption, such dates being March 1 and September 1, commencing on the date specified in the Pricing Certificate.

“MSRB” means the Municipal Securities Rulemaking Board.

“Net Revenues” means the Gross Revenues less the Operation and Maintenance Expenses.

“Note Payment Fund” means the fund so designated in Section 8.01(b) hereof.

“Operation and Maintenance Expenses” means the reasonable and proper expenses of operating and maintaining the System, including all salaries, labor, materials, repairs and extensions necessary to render efficient service; provided, however, that only such repairs and extensions as are necessary to keep the System in operation or which are necessary to meet some physical accident or condition that would otherwise impair the Bonds, the Previously Issued Senior Lien Bonds and any Additional Bonds shall be included as Operation and Maintenance Expenses.

“Owner” means the person who is the registered owner of a Bond or Bonds.

“Paying Agent/Registrar” means Computershare Trust Company, N.A. (or such other entity or banking association determined by the Pricing Officer in the Pricing Certificate), or any successor thereto or replacement therefor as provided in this Ordinance.

“Previously Issued Senior Lien Bonds” means the outstanding bonds of the following issues of the City (such bonds being designated as “Previously Issued Bonds” in ordinances adopted prior to March 1, 1993):

- (1) Water and Sewer Revenue Bonds, Series 2003A, authorized by ordinance duly passed and approved August 26, 2003;
- (2) Water and Sewer Revenue Refunding Bonds, Series 2014, authorized by ordinance duly passed and adopted on January 7, 2014;
- (3) Water and Sewer Revenue Refunding Bonds, Series 2015, authorized by ordinance duly passed and adopted on December 2, 2014;
- (4) Water and Sewer Revenue Bonds, Series 2015A, authorized by ordinance duly passed and adopted on June 16, 2015;
- (5) Water and Sewer Revenue Bonds, Series 2015B, authorized by ordinance duly passed and adopted on October 27, 2015;
- (6) Water and Sewer Revenue Refunding Bonds, Series 2015C, authorized by ordinance duly passed and adopted on October 27, 2015;
- (7) Water and Sewer Revenue Improvement and Refunding Bonds, Series 2016, authorized by ordinance duly passed and adopted on June 28, 2016;
- (8) Water and Sewer Revenue Bonds, Series 2016A, authorized by ordinance duly passed and adopted on October 18, 2016;
- (9) Water and Sewer Revenue Improvement and Refunding Bonds, Series 2017, authorized by ordinance duly passed and adopted on September 5, 2017;
- (10) Water and Sewer Revenue Bonds, Series 2017A, authorized by ordinance duly passed and adopted on October 31, 2017;
- (11) Water and Sewer Revenue Refunding Bonds, Series 2018, authorized by ordinance duly passed and adopted on October 30, 2018;
- (12) Water and Sewer Revenue Bonds, Series 2019, authorized by ordinance duly passed and adopted on March 19, 2019;
- (13) Water and Sewer Revenue Refunding Bonds, Series 2019A, authorized by ordinance duly passed and adopted on August 6, 2019;

(14) Water and Sewer Revenue Refunding Bonds, Series 2019B, authorized by ordinance duly passed and adopted on August 6, 2019;

(15) Water and Sewer Revenue Refunding Bonds, Series 2020, authorized by ordinance duly passed and adopted on August 4, 2020;

(16) Water and Sewer Revenue Refunding Bonds, Taxable Series 2020A, authorized by ordinance duly passed and adopted on August 4, 2020;

(17) Water and Sewer Revenue Refunding Bonds, Series 2021, authorized by ordinance duly passed and adopted on March 2, 2021;

(18) Water and Sewer Revenue Refunding Bonds, Taxable Series 2021A, authorized by ordinance duly passed and adopted on March 2, 2021; and

(19) City of El Paso, Texas, Water and Sewer Revenue Improvement and Refunding Bonds, Series 2022, authorized by ordinance duly passed and adopted on March 29, 2022.

“Pricing Certificate” means collectively one or more pricing certificates that set forth the terms of one or more series of Bonds in accordance with Section 3.02 of this Ordinance and executed by the Pricing Officer, all in accordance with the provisions of Chapter 1207 and Chapter 1371.

“Pricing Officer” means the President/Chief Executive Officer of the System, or in the absence thereof, the Vice President of Strategic, Financial and Management Services of the System or the Chief Financial Officer of the System, each acting in such capacity severally and not jointly.

“Purchaser” means collectively the initial purchasers of each series of Bonds issued hereunder as named in the Pricing Certificate(s).

“Record Date” means with respect to each interest payment date the fifteenth day of the month next preceding such interest payment date.

“Refunded Commercial Paper Notes” means the commercial paper notes described in the Pricing Certificate.

“Register” means the Register specified in Section 3.07(a) of this Ordinance.

“Reserve Fund” means the fund by that name described in Section 8.01(a)(iii) hereof.

“Reserve Fund Requirement” means the amount which is equal to the average annual principal and interest requirements on the Bonds, the Previously Issued Senior Lien Bonds and any Additional Bonds at any time outstanding.

“Revenue Fund” means the Waterworks and Sewage Fund established in Section 8.01(a)(i) hereof.

“Rule” means SEC Rule 15c2-12, as amended from time to time or officially interpreted by the SEC.

“SEC” means the United States Securities and Exchange Commission.

“Subordinate Lien Obligations” shall mean the obligations of the City under the City’s Commercial Paper Notes, Series A and the documents pertaining thereto.

“System” means the complete waterworks plant and system of the City as they now exist and may be improved, added to, or extended hereafter, and the complete sewer system of the City as it now exists and may hereafter be improved, added to, or extended, there being included in such term all water and sewer facilities now or hereafter owned or operated by the City, lying within and without the boundaries of the City, and including all real estate and real and personal property of every kind and nature comprising any part of or used or useful in the operation of the water and sewer facilities of the City.

Section 1.02 Findings. The declarations, determinations and findings declared, made and found in the preamble to this Ordinance are hereby adopted, restated and made a part of the operative provisions hereof.

Section 1.03 Table of Contents, Titles and Headings. The table of contents, titles and headings of the Articles and Sections of this Ordinance have been inserted for convenience of reference only and are not to be considered a part hereof and shall not in any way modify or restrict any of the terms or provisions hereof and shall never be considered or given any effect in construing this Ordinance or any provision hereof or in ascertaining intent, if any question of intent should arise.

Section 1.04 Interpretation.

(a) Unless the context requires otherwise, words of the masculine gender shall be construed to include correlative words of the feminine and neuter genders and vice versa, and words of the singular number shall be construed to include correlative words of the plural number and vice versa.

(b) This Ordinance and all the terms and provisions hereof shall be liberally construed to effectuate the purposes set forth herein to sustain the validity of this Ordinance.

## ARTICLE 2

### SECURITY FOR THE BONDS

Section 2.01 Security for the Bonds. The Bonds, the Previously Issued Senior Lien Bonds and any Additional Bonds, both principal and interest, are and shall be equally and ratably secured by and payable from an irrevocable first lien on and pledge of the Net Revenues.

Section 2.02 Limited Obligations. The Bonds, the Previously Issued Senior Lien Bonds and any Additional Bonds, are special obligations of the City, payable solely from the Net Revenues, and do not constitute a prohibited indebtedness of the City. Neither the Bonds, the

Previously Issued Senior Lien Bonds, nor the Additional Bonds shall ever be payable out of funds raised or to be raised by taxation.

Section 2.03 Security Interest. The City represents that, under Chapter 1208.002, Texas Government Code, a security interest in property, other than real property, that is created by the City is valid and effective according to the terms of the security agreement and is perfected from the time the security agreement is entered into or adopted continuously through the termination of the security interest, without physical delivery or transfer of control of the property, filing of a document, or another act. The City covenants that, if Chapter 1208.002 is amended at any time while the Bonds, the Previously Issued Senior Lien Bonds or Additional Bonds are outstanding and unpaid, the City shall take all actions required in order to preserve for the Owners of the Bonds, the Previously Issued Senior Lien Bonds or Additional Bonds a perfected security interest in the property in which such security interest is granted pursuant to Section 2.01 hereof.

### ARTICLE 3

#### AUTHORIZATION; GENERAL TERMS AND PROVISIONS REGARDING THE BONDS

##### Section 3.01 Authorization.

(a) Revenue bonds of the City are hereby authorized to be issued, in one or more series, in an amount not to exceed the maximum aggregate principal amount set forth in Section 3.02 hereof. As specified in a Pricing Certificate, such revenue bonds shall be designated and bear the title the “City of El Paso, Texas, Water and Sewer Revenue Bonds” and such additional or different series or designations as specified by the Pricing Officer in an applicable Pricing Certificate.

(b) The Bonds shall be issued for the purposes of (i) refunding the Refunded Commercial Paper Notes, (ii) constructing, acquiring, purchasing, renovating, enlarging, equipping, and improving System properties and facilities, and (iii) paying the costs of issuing the Bonds, all as provided in the applicable Pricing Certificate and in accordance with the Constitution and laws of the State of Texas, particularly Chapter 1207, Chapter 1371, Chapter 1502 and the Charter of the City.

##### Section 3.02 Delegation of Authority to Pricing Officer.

(a) As authorized by Chapter 1207 and Chapter 1371, the Pricing Officer is hereby authorized to act on behalf of the City in selling and delivering the Bonds, in one or more series, and carrying out the other procedures specified in this Ordinance, including selection of the principal amount of the Refunded Commercial Paper Notes to be refunded, determining the aggregate original principal amount of each series of the Bonds, the Initial Date of each series of Bonds, any additional or different designation or title by which the Bonds shall be known, the price at which the Bonds of each series will be sold, the manner of sale (negotiated, privately placed or competitively bid), the years in which the Bonds of each series will mature, the terms of any bond insurance applicable to each series of the Bonds, the principal amount to mature in each of such years, the rate of interest to be borne by each such maturity, the interest payment dates, the price and terms upon and at which the Bonds of each series shall be subject to redemption prior to

maturity at the option of the City, as well as any mandatory sinking fund redemption provisions, the designation of a paying agent/registrar, the designation of an escrow agent, if necessary, and all other matters relating to the issuance, sale, and delivery of the Bonds all of which shall be specified in a Pricing Certificate; provided that:

(i) the aggregate original principal amount of all series of Bonds issued hereunder shall not exceed \$441,000,000;

(ii) the aggregate true interest cost percentage for each series of Bonds issued hereunder shall not exceed 6.50%; and

(iii) the maximum maturity date for each series of Bonds issued hereunder shall not exceed December 31, 2049.

(b) In establishing the aggregate principal amount of each series of Bonds, the Pricing Officer shall establish an amount not exceeding the amount authorized in Subsections (a)(i) above, which shall be sufficient in amount to provide for the purposes for which the Bonds are authorized and to pay costs of issuing the Bonds. Unless otherwise extended by an act of City Council, the delegation made hereby shall expire if not exercised by the Pricing Officer within 270 days from the date of the adoption of this Ordinance. The Pricing Officer may exercise such delegation on more than one occasion during such time period.

(c) The execution of a Pricing Certificate shall evidence the sale date of the applicable series of Bonds by the City to the Purchaser.

(d) If the Pricing Officer determines that such insurance results in a net reduction of the City's interest costs associated with the Bonds, then the Pricing Officer is authorized, in connection with effecting the sale of the Bonds, to obtain from a municipal bond insurance company (the "Insurer") a municipal bond insurance policy in support of the Bonds. To that end, should the Pricing Officer exercise such authority and commit the City to obtain a municipal bond insurance policy, for so long as such policy is in effect, the requirements of the Insurer relating to the issuance of such policies are incorporated by reference into this Ordinance and made a part hereof for all purposes, notwithstanding any other provision of this Ordinance to the contrary. Each of the City Manager of the City, the President/Chief Executive Officer of the System and the Pricing Officer shall have the authority to execute any documents to effect the issuance of such policy by the Insurer.

### Section 3.03 Date, Denomination, Maturities, Numbers and Interest.

(a) The Bonds shall have the Initial Date specified in the Pricing Certificate. The Bonds shall be in fully registered form, without coupons, and shall be numbered consecutively from one upward, except the Initial Bond(s), which shall be numbered as specified in Section 6.02.

(b) The Bonds shall be in the denomination of \$5,000 or any integral multiple thereof, shall mature on March 1 in the years and in the principal amounts and shall bear interest at the per annum rates set forth in the Pricing Certificate.

(c) Interest shall accrue and be paid on each Bond respectively until its maturity or earlier redemption from the date specified in the Pricing Certificate or the most recent interest



payment date to which interest has been paid or provided for at the per annum rates specified in the schedule contained in the Pricing Certificate. Such interest shall be payable semiannually on March 1 and September 1 of each year, commencing on the date specified in the Pricing Certificate, computed on the basis of a 360-day year of twelve 30-day months.

Section 3.04 Medium, Method and Place of Payment.

(a) The principal of and interest on the Bonds shall be paid in lawful money of the United States of America, as provided in this Section.

(b) Interest on the Bonds shall be paid to the Owners thereof as shown in the Register at the close of business on the Record Date by check (dated as of the Interest Payment Date) and sent by the Paying Agent/Registrar to the person entitled to such payment, first class United States mail, postage prepaid, to the address of such person as it appears in the Register, or by such other customary banking arrangements acceptable to the Paying Agent/Registrar and the person to whom interest is paid; provided, however, that such person shall bear all risk and expense of such other customary banking arrangements.

(c) The principal of each Bond shall be paid to the Owner of such Bond on the due date thereof (whether at the maturity date or the date of prior redemption thereof) upon presentation and surrender of such Bond at the Designated Payment/Transfer Office of the Paying Agent/Registrar.

(d) If the date for the payment of the principal of or interest on the Bonds is not a Business Day, the date for such payment shall be the next succeeding Business Day, and payment on such date shall for all purposes be deemed to have been made on the due date thereof as specified in this Section.

(e) In the event of a nonpayment of interest on a Bond on a scheduled payment date, and for thirty (30) days thereafter, a new record date for such interest payment (a "Special Record Date") will be established by the Paying Agent/Registrar, if and when funds for the payment of such interest have been received from the City. Notice of the Special Record Date and of the scheduled payment date of the past due interest (which shall be fifteen (15) days after the Special Record Date) shall be sent at least five business days prior to the Special Record Date by United States mail, first class, postage prepaid, to the address of each Owner of a Bond appearing on the books of the Paying Agent/Registrar at the close of business on the last business day next preceding the date of mailing of such notice.

(f) Unclaimed payments shall be segregated in a special escrow account and held in trust, uninvested by the Paying Agent/Registrar, for the account of the Owner of the Bonds to which the unclaimed payments pertain. Subject to Title 6 of the Texas Property Code, payments remaining unclaimed by the Owners entitled thereto for three years after the applicable payment or redemption date shall be applied to the next payment or payments on the Bonds thereafter coming due and, to the extent any such money remains after the retirement of all outstanding Bonds, shall be paid to the City to be used for any lawful purpose. Thereafter, neither the City, the Paying Agent/Registrar nor any other person shall be liable or responsible to any Owners of

such Bonds for any further payment of such unclaimed moneys or on account of any such Bonds, subject to Title 6 of the Texas Property Code.

Section 3.05 Execution and Initial Registration. The Bonds shall be executed on behalf of the City by the Mayor or Mayor Pro Tem and the City Clerk or Alternate City Clerk as of the date of adoption of this Ordinance, by their manual or facsimile signatures, and the official seal of the City shall be impressed or placed in facsimile thereon. Such facsimile signatures on the Bonds shall have the same effect as if each of the Bonds had been signed manually and in person by each of such officers, and such facsimile seal on the Bonds shall have the same effect as if the official seal of the City had been manually impressed upon each of the Bonds.

(a) In the event any officer of the City whose manual or facsimile signature appears on the Bonds ceases to be such officer before the authentication of such Bonds or before the delivery thereof, such facsimile signature nevertheless shall be valid and sufficient for all purposes as if such officer had remained in such office.

(b) Except as provided below, no Bond shall be valid or obligatory for any purpose or be entitled to any security or benefit of this Ordinance unless and until there appears thereon the Certificate of Paying Agent/Registrar substantially in the form provided herein, duly authenticated by manual execution by an officer or duly authorized signatory of the Paying Agent/Registrar. It shall not be required that the same officer or authorized signatory of the Paying Agent/Registrar sign the Certificate of Paying Agent/Registrar on all of the Bonds. In lieu of the executed Certificate of Paying Agent/Registrar described above, the Initial Bond delivered on the Closing Date shall have attached thereto the Comptroller's Registration Certificate substantially in the form provided herein, manually executed by the Comptroller of Public Accounts of the State of Texas, or by his duly authorized agent, which certificate shall be evidence that the Initial Bond of each series has been duly approved by the Attorney General of the State of Texas and that they are valid and binding special obligations of the City, and have been registered by the Comptroller of Public Accounts of the State of Texas.

(c) On the Closing Date, one Initial Bond for each series of the Bonds, payable in stated installments to the Purchaser or its designee, executed by manual or facsimile signature of the Mayor or Mayor Pro Tem and City Clerk or Alternate City Clerk, approved by the Attorney General, and registered and manually signed by the Comptroller of Public Accounts will be delivered to the Purchaser or its designee. Upon payment for each Initial Bond, the Paying Agent/Registrar shall cancel the Initial Bond and deliver registered definitive Bonds to DTC in accordance with Sections 3.09 and 3.11.

Section 3.06 Ownership.

(a) The City, the Paying Agent/Registrar and any other person may treat the person in whose name any Bond is registered as the absolute owner of such Bond for the purpose of making and receiving payment of the principal, for the further purpose of making and receiving payment of the interest thereon (subject to the terms of this Ordinance requiring the Paying Agent/Registrar to make payments of interest to the person who is the registered owner on the Record Date or the Special Record Date), and for all other purposes, whether or not such Bond is overdue, and neither the City nor the Paying Agent/Registrar shall be bound by any notice or knowledge to the contrary.

(b) All payments made to the person deemed to be the Owner of any Bond in accordance with this Section shall be valid and effectual and shall discharge the liability of the City and the Paying Agent/Registrar upon such Bond to the extent of the sums paid.

Section 3.07 Registration, Transfer and Exchange.

(a) So long as any Bonds remain outstanding, the City shall cause the Paying Agent/Registrar to keep at the Designated Payment/Transfer Office a register (the "Register") in which, subject to such reasonable regulations as it may prescribe, the Paying Agent/Registrar shall provide for the registration and transfer of Bonds in accordance with this Ordinance.

(b) Registration of any Bond may be transferred in the Register only upon the presentation and surrender thereof at the Designated Payment/Transfer Office of the Paying Agent/Registrar for transfer of registration and cancellation, together with proper written instruments of assignment, in form and with guarantee of signatures satisfactory to the Paying Agent/Registrar, evidencing assignment of the Bonds, or any portion thereof in any integral multiple of \$5,000, to the assignee or assignees thereof, and the right of such assignee or assignees thereof to have the bond or any portion thereof registered in the name of such assignee or assignees. No transfer of any Bond shall be effective until entered in the Register. Upon assignment and transfer of any Bond or portion thereof, a new Bond or Bonds will be issued by the Paying Agent/Registrar in exchange for such transferred and assigned Bond. To the extent possible the Paying Agent/Registrar will issue such new Bond or Bonds in not more than three business days after receipt of the Bond to be transferred in proper form and with proper instructions directing such transfer.

(c) Any Bond may be exchanged only upon the presentation and surrender thereof at the Designated Payment/Transfer Office of the Paying Agent/Registrar, together with a written request therefor duly executed by the registered owner or assignee or assignees thereof, or its or their duly authorized attorneys or representatives, with guarantees of signatures satisfactory to the Paying Agent/Registrar, for a Bond or Bonds of like series, of the same maturity and interest rate and in any authorized denomination and in an aggregate principal amount equal to the unpaid principal amount of the Bond presented for exchange. If a portion of any Bond is redeemed prior to its scheduled maturity as provided herein, a substitute Bond or Bonds of like series, having the same maturity date, bearing interest at the same rate, in the denomination or denominations of any integral multiple of \$5,000 at the request of the registered owner, and in an aggregate principal amount equal to the unredeemed portion thereof, will be issued to the registered owner upon surrender thereof for cancellation. To the extent possible, a new Bond or Bonds will be required to be delivered by the Paying Agent/Registrar to the registered owner of the Bond or Bonds in not more than three business days after receipt of the Bond to be exchanged in proper form and with proper instructions directing such exchange.

(d) Each Bond issued in exchange for any Bond or portion thereof assigned or transferred shall be of like series, of the same tenor and shall have the same maturity date and bear interest at the same rate and in the same manner as the Bond for which it is being exchanged. Each substitute Bond shall bear a letter and/or number to distinguish it from each other Bond. The Paying Agent/Registrar shall exchange the Bonds as provided herein, and each substitute Bond delivered in accordance with this Section shall constitute an original additional contractual

obligation of the City and shall be entitled to the benefits and security of this Ordinance to the same extent as the Bond or Bonds in lieu of which such substitute Bond is delivered.

(e) The City will pay the Paying Agent/Registrar's reasonable and customary charge for the initial registration of the Bonds and the subsequent exchange of the Bonds pursuant to the provisions hereof. However, the Paying Agent/Registrar will require the Owner to pay a sum sufficient to cover any tax or other governmental charge that is authorized to be imposed in connection with the registration, transfer or exchange of a Bond. In addition, the City hereby covenants with the Owners of the Bonds that it will (i) pay the reasonable and standard or customary fees and charges of the Paying Agent/Registrar for its services with respect to the payment of the principal of and interest on the Bonds, when due, and (ii) pay the fees and charges of the Paying Agent/Registrar for services with respect to the transfer, registration and exchange of Bonds as provided herein to the extent such fees and charges are payable hereunder by the City.

(f) Neither the City nor the Paying Agent/Registrar shall be required to issue, transfer or exchange any Bond called for redemption, in whole or in part, where such redemption is scheduled to occur within 45 calendar days of the transfer or exchange date; provided, however, such limitation shall not be applicable to an exchange by the owner of the uncalled principal balance of a Bond.

#### Section 3.08 Cancellation and Authentication.

(a) All Bonds paid or redeemed before scheduled maturity in accordance with this Ordinance, and all Bonds in lieu of which exchange Bonds or replacement Bonds are authenticated and delivered in accordance with this Ordinance, shall be canceled upon the making of proper records regarding such payment, redemption, exchange or replacement.

(b) Each substitute Bond issued in exchange for or replacement of (pursuant to the provisions of Section 3.10 hereof) any Bond or Bonds issued under this Ordinance shall have printed thereon a Paying Agent/Registrar's Authentication Certificate, in the form hereinafter set forth. An authorized representative of the Paying Agent/Registrar shall, before the delivery of any such bond, manually sign and date such Certificate, and no such Bond shall be deemed to be issued or outstanding unless such Certificate is so executed. No additional ordinances, orders, or resolutions need be passed or adopted by the City Council or any other body or person so as to accomplish the foregoing exchange or replacement of any Bond or portion thereof, and the Paying Agent/Registrar shall provide for the printing, execution, and delivery of the substitute Bonds in the manner prescribed herein. Pursuant to Texas Government Code, Chapter 1201, as amended, the duty of exchange or replacement of Bonds as aforesaid is hereby imposed upon the Paying Agent/Registrar, and, upon the execution of the above Paying Agent/Registrar's Authentication Certificate, the exchanged or replaced Bonds shall be valid, incontestable, and enforceable in the same manner and with the same effect as the Bonds which originally were delivered pursuant to this Ordinance, approved by the Attorney General, and registered by the Comptroller of Public Accounts.

Section 3.09 Temporary Bonds.

(a) Pending the preparation of definitive Bonds, the City may execute and, upon the City's request, the Paying Agent/Registrar shall authenticate and deliver, one or more temporary Bonds that are printed, lithographed, typewritten, mimeographed or otherwise produced, in any denomination, substantially of the tenor of the definitive Bonds in lieu of which they are delivered, without coupons, and with such appropriate insertions, omissions, substitutions and other variations as the officers of the City executing such temporary Bonds may determine, as evidenced by their signing of such temporary Bonds.

(b) Until exchanged for Bonds in definitive form, such Bonds in temporary form shall be entitled to the benefit and security of this Ordinance. The City, without unreasonable delay, shall prepare, execute and deliver to the Paying Agent/Registrar, and thereupon, upon the presentation and surrender of the Bond or Bonds in temporary form to the Paying Agent/Registrar, the Paying Agent/Registrar shall authenticate and deliver in exchange therefor a Bond or Bonds of the same maturity and series, in definitive form, in the authorized denomination, and in the same aggregate principal amount as the Bond or Bonds in temporary form surrendered. Such exchange shall be made without the making of any charge therefor to any Owner.

Section 3.10 Replacement Bonds.

(a) Upon the presentation and surrender to the Paying Agent/Registrar of a mutilated Bond, the Paying Agent/Registrar shall authenticate and deliver in exchange therefor a replacement Bond of like series, of like tenor and principal amount, bearing a number not contemporaneously outstanding. The City or the Paying Agent/Registrar may require the Owner of such Bond to pay a sum sufficient to cover any tax or other governmental charge that is authorized to be imposed in connection therewith and any other expenses connected therewith.

(b) In the event that any Bond is lost, apparently destroyed or wrongfully taken, the Paying Agent/Registrar, pursuant to the applicable laws of the State of Texas and in the absence of notice or knowledge that such Bond has been acquired by a bona fide purchaser, shall authenticate and deliver a replacement Bond of like tenor and principal amount, bearing a number not contemporaneously outstanding, provided that the Owner first:

(i) furnishes to the Paying Agent/Registrar satisfactory evidence of his or her ownership of and the circumstances of the loss, destruction or theft of such Bond;

(ii) furnishes such security or indemnity as may be required by the Paying Agent/Registrar and the City, to save each of them harmless;

(iii) pays all expenses and charges in connection therewith, including, but not limited to, printing costs, legal fees, fees of the Paying Agent/Registrar and any tax or other governmental charge that is authorized to be imposed; and

(iv) satisfies any other reasonable requirements imposed by the City and the Paying Agent/Registrar.

(c) If, after the delivery of such replacement Bond, a bona fide purchaser of the original Bond in lieu of which such replacement Bond was issued presents for payment such original Bond, the City and the Paying Agent/Registrar shall be entitled to recover such replacement Bond from

the person to whom it was delivered or any person taking therefrom, except a bona fide purchaser, and shall be entitled to recover upon the security or indemnity provided therefor to the extent of any loss, damage, cost or expense incurred by the City or the Paying Agent/Registrar in connection therewith.

(d) In the event that any such mutilated, lost, apparently destroyed or wrongfully taken Bond has become or is about to become due and payable, the Paying Agent/Registrar, in its discretion, without the necessity of issuing a replacement Bond, may pay such Bond on the date on which such Bond becomes due and payable.

(e) Each replacement Bond delivered in accordance with this Section shall constitute an original additional contractual obligation of the City and shall be entitled to the benefits and security of this Ordinance to the same extent as the Bond or Bonds in lieu of which such replacement Bond is delivered.

### Section 3.11 Book-Entry-Only System.

(a) Notwithstanding any other provision hereof, upon initial issuance of the Bonds, the ownership of the Bonds shall be registered in the name of Cede & Co., as nominee of DTC. The definitive Bonds shall be initially issued in the form of a single separate fully registered certificate for each of the maturities thereof.

(b) With respect to Bonds registered in the name of Cede & Co., as nominee of DTC, the City and the Paying Agent/Registrar shall have no responsibility or obligation to any DTC Participant or to any person on behalf of whom such a DTC Participant holds an interest in the Bonds. Without limiting the immediately preceding sentence, the City and the Paying Agent/Registrar shall have no responsibility or obligation with respect to (i) the accuracy of the records of DTC, Cede & Co. or any DTC Participant with respect to any ownership interest in the Bonds, (ii) the delivery to any DTC Participant or any other person, other than an Owner, as shown on the Register, of any notice with respect to the Bonds, including any notice of redemption, or (iii) the payment to any DTC Participant or any other person, other than an Owner, as shown in the Register of any amount with respect to principal of, premium, if any, or interest on the Bonds. Notwithstanding any other provision of this Ordinance to the contrary, the City and the Paying Agent/Registrar shall be entitled to treat and consider the person in whose name each Bond is registered in the Register as the absolute owner of such Bond for the purpose of payment of principal of, premium, if any, and interest on, the Bonds, for the purpose of all matters with respect to such Bond, for the purpose of registering transfer with respect to such Bond, and for all other purposes whatsoever. The Paying Agent/Registrar shall pay all principal of, premium, if any, and interest on the Bonds only to or upon the order of the respective owners, as shown in the Register as provided in this Ordinance, or their respective attorneys duly authorized in writing, and all such payments shall be valid and effective to fully satisfy and discharge the City's obligations with respect to payment of, premium, if any, and interest on the Bonds to the extent of the sum or sums so paid. No person other than an owner, as shown in the Register, shall receive a certificate evidencing the obligation of the City to make payments of amounts due pursuant to this Ordinance. Upon delivery by DTC to the Paying Agent/Registrar of written notice to the effect that DTC has determined to substitute a new nominee in place of Cede & Co., the word "Cede & Co." in this Ordinance shall refer to such new nominee of DTC.

Section 3.12 Successor Securities Depository; Transfer Outside Book-Entry Only System. In the event that the City or the Paying Agent/Registrar determines that DTC is incapable of discharging its responsibilities described herein and in the representation letter of the City to DTC, or in the event DTC discontinues the services described herein, the City or the Paying Agent/Registrar shall (i) appoint a successor securities depository, qualified to act as such under Section 17(a) of the Securities Exchange Act of 1934, as amended, notify DTC and DTC Participants of the appointment of such successor securities depository and transfer one or more separate Bonds to such successor securities depository or (ii) notify DTC and DTC Participants of the availability through DTC of Bonds and transfer one or more separate Bonds to DTC Participants having Bonds credited to their DTC accounts. In such event, the Bonds shall no longer be restricted to being registered in the Register in the name of Cede & Co., as nominee of DTC, but may be registered in the name of the successor securities depository, or its nominee, or in whatever name or names Owners transferring or exchanging Bonds shall designate, in accordance with the provisions of this Ordinance.

Section 3.13 Payments to Cede & Co. Notwithstanding any other provision of this Ordinance to the contrary, so long as any Bonds are registered in the name of Cede & Co., as nominee of DTC, all payments with respect to principal of, premium, if any, and interest on the Bonds, and all notices with respect to such Bonds, shall be made and given, respectively, in the manner provided in the blanket representation letter of the City to DTC.

#### ARTICLE 4

#### REDEMPTION OF BONDS BEFORE MATURITY

Section 4.01 Limitation on Redemption. The Bonds of each series shall be subject to redemption before their scheduled maturity only as provided in the applicable Pricing Certificate.

#### ARTICLE 5

#### PAYING AGENT/REGISTRAR

Section 5.01 Appointment of Initial Paying Agent/Registrar.

(a) Unless otherwise specified in a Pricing Certificate, Computershare Trust Company, N.A., a national banking association organized under the laws of the United States of America authorized to do business in the State of Texas, is hereby appointed as the initial Paying Agent/Registrar for the Bonds.

(b) The Pricing Officer is authorized and directed to execute an agreement with the Paying Agent/Registrar specifying the duties and responsibilities of the City and the Paying Agent/Registrar substantially in the form attached hereto as Exhibit A.

Section 5.02 Qualifications of Paying Agent/Registrar. Each Paying Agent/Registrar shall be a commercial bank, a national banking association trust company organized under the laws of the State of Texas, or other entity duly qualified and legally authorized to serve as, and perform the duties and services of, paying agent and registrar for the Bonds.

Section 5.03 Maintaining Paying Agent/Registrar.

(a) At all times while any Bonds are outstanding, the City will maintain a Paying Agent/Registrar that is qualified under Section 5.02 of this Ordinance.

(b) If the Paying Agent/Registrar resigns or otherwise ceases to serve as such, the City will promptly appoint a replacement.

Section 5.04 Termination of Paying Agent/Registrar. The City reserves the right to terminate the appointment of any Paying Agent/Registrar by delivering to the entity whose appointment is to be terminated a certified copy of a resolution of the City (i) giving notice of the termination of the appointment, stating the effective date of such termination, and (ii) appointing a successor Paying Agent/Registrar.

Section 5.05 Notice of Change of Paying Agent/Registrar to Owners. Promptly upon each change in the entity serving as Paying Agent/Registrar, the City will cause notice of the change to be sent to each Owner by first class United States mail, postage prepaid, at the address in the Register, stating the effective date of the change and the name and mailing address of the replacement Paying Agent/Registrar.

Section 5.06 Agreement of Paying Agent/Registrar to Perform Duties and Functions. By accepting the appointment as Paying Agent/Registrar, the Paying Agent/Registrar is deemed to have agreed to the provisions of this Ordinance and that it will perform the duties and functions of Paying Agent/Registrar prescribed hereby.

Section 5.07 Delivery of Records to Successor. If a Paying Agent/Registrar is replaced, such Paying Agent/Registrar, promptly upon the appointment of the successor, will deliver the Register (or a copy thereof) and all other pertinent books and records relating to the Bonds to the successor Paying Agent/Registrar.

ARTICLE 6

FORM OF THE BONDS

Section 6.01 Form Generally.

(a) The Bonds of each series, including the Registration Certificate of the Comptroller of Public Accounts of the State of Texas, the Certificate of the Paying Agent/Registrar, and the Assignment to appear thereon, (i) shall be substantially in the form set forth in **Exhibit B** attached hereto with such appropriate insertions, omissions, substitutions, and other variations as are permitted or required by this Ordinance and the Pricing Certificate, and (ii) may have such letters, numbers, or other marks of identification (including identifying numbers and letters of the Committee on Uniform Securities Identification Procedures of the American Bankers Association) and such legends and endorsements (including any reproduction of an opinion of counsel) thereon as, consistently herewith, may be determined by the City or by the officers executing such Bonds, as evidenced by their execution thereof. Any portion of the text of any Bonds may be set forth on the reverse side thereof, with an appropriate reference thereto on the face of the Bonds. The



applicable Pricing Certificate shall set forth the final and controlling terms of the Bonds of each series.

(b) The definitive Bonds shall be typewritten, printed, lithographed, or engraved, and may be produced by any combination of these methods or produced in any other similar manner, all as determined by the officers executing such Bonds, as evidenced by their execution thereof. The Initial Bond submitted to the Attorney General of the State of Texas may be typewritten and photocopied or otherwise reproduced.

Section 6.02 Form of the Bonds. The form of the Bonds of each series, including the form of the Registration Certificate of the Comptroller of Public Accounts of the State of Texas (which shall only appear on the Initial Bond), the form of Certificate of the Paying Agent/Registrar and the form of Assignment appearing on the Bonds shall be substantially in the form of attached **Exhibit B.**

Section 6.03 CUSIP Registration. The City may secure identification numbers through the CUSIP Service Bureau Division of Standard & Poor's Corporation, New York, New York, and may authorize the printing of such numbers on the face of the Bonds. It is expressly provided, however, that the presence or absence of CUSIP numbers on the Bonds shall be of no significance or effect as regards the legality thereof and neither the City nor the attorneys approving such Bonds as to legality are to be held responsible for CUSIP numbers incorrectly printed on the Bonds.

Section 6.04 Legal Opinion. The approving legal opinion of Bond Counsel may be attached to or printed on each Bond over the certification of the City Clerk or Alternate City Clerk of the City, which certification may be executed in facsimile.

Section 6.05 Statement of Insurance. A statement relating to a municipal bond insurance policy, if any, to be issued for the Bonds may be printed on or attached to each Bond.

## ARTICLE 7

### PUBLIC SERVICE BOARD

#### Section 7.01 Public Service Board.

(a) Pursuant to the authority contained in Texas Government Code, Section 1502.071, as amended, during such time as any of the Bonds herein authorized are outstanding and unpaid, the Public Service Board shall have complete authority and control of the management and operation of the System.

(b) The Board shall consist of seven members, one of whom shall be the Mayor of the City who shall ex officio be one member of the Board. Each term of office shall be four years with no member being appointed to more than two consecutive terms. To the extent not prohibited by State law, each member shall continue to serve until his or her successor is appointed and qualified, or until 30 days have passed beyond the expiration of such term, whichever event occurs first. After that time a vacancy on the Board shall exist and the former member shall have no power to vote or participate in Board proceedings; but such vacancy shall not serve to reduce the number of members required for a quorum.

Each vacancy in Board membership whether occasioned by expiration of office or otherwise shall be filled by the City Council from three persons eligible to serve as Board members and presented to City Council. A selection committee selected by the City Council and comprised of the Board and such additional members as appointed by City Council shall agree upon and submit to City Council the names of such three eligible persons.

Any member of the Board, other than the Mayor, who shall be continuously absent from all meetings of the Board for a period of three consecutive months shall, unless he or she shall be granted leave of absence by the unanimous vote of the remaining members of the Board, be removed from office, but only for adequate cause. As City Council appointees, members of the Board are subject to the City's ethics ordinance, Chapter 2.92 of the City Code of the City, as amended, and must comply with the applicable provisions contained therein.

(c) The Board shall elect one of its own members as Chairman and one as Vice-Chairman and appoint a Secretary and a Treasurer or a Secretary-Treasurer, who may, but need not, be a member or members of the Board. The Board may make such regulations or any by-laws for the orderly handling of its affairs as it may in its discretion see fit and shall thereafter, subject to the pertinent laws of the State of Texas, operate and manage the System with the same freedom and in the same manner as are ordinarily enjoyed by the Board of Directors of a private corporation operating properties of a similar nature.

Subject to the provisions and restrictions contained in this Ordinance, all of which shall be binding on the Board, the Board shall have complete authority and control of the management and operations of the System and the expenditure and application of its revenues.

(d) The Board shall elect or appoint all officers and employees which it may consider desirable, including a President/Chief Executive Officer of the System. The President/Chief Executive Officer shall be responsible to appoint officers and employees that directly report to the President/Chief Executive Officer, including an attorney or attorneys, vice president(s) and such other personnel that directly report to the President/Chief Executive Officer. All other officers and employees, except members of the Board, the President/Chief Executive Officer, attorneys, vice president(s) and persons directly reporting to the President/Chief Executive Officer or vice president(s), shall serve under the City Civil Service provisions as are or may be established by the Charter of the City or the laws of Texas, and the Board shall have the same authority with respect to such officers and employees as that of the City Council with respect to other officers and other employees of the City. The Board shall obtain and keep continually in force an employers' fidelity and indemnity bond of the so-called blanket type, written by a solvent and recognized indemnity company, and covering losses to the amount not to exceed \$50,000.

(e) The members of the Board, other than the Mayor shall, for each meeting attended, receive the sum of \$20.00, except that the amount so paid to any member of the Board in any fiscal year shall not exceed \$5,000. The members of the Board shall not personally be liable for any act or omission not willfully fraudulent or committed in bad faith.

ARTICLE 8

FUNDS; FLOW OF FUNDS

Section 8.01 Special Funds.

(a) The City covenants and agrees that all revenues derived from the operation of the System shall be kept separate from other funds of the City. To that end, the following special funds heretofore established are reaffirmed and shall be maintained at the Depository Bank so long as any of the Bonds, the Previously Issued Senior Lien Bonds, or any Additional Bonds are outstanding and unpaid, to-wit:

(i) “City of El Paso, Texas, Water and Sewer Revenue Bonds Waterworks and Sewage Fund” (herein called the “Revenue Fund”);

(ii) “City of El Paso, Texas, Water and Sewer Revenue Bonds Interest and Sinking Fund” (herein called the “Interest and Sinking Fund”);

(iii) “City of El Paso, Texas, Water and Sewer Revenue Bonds Reserve Fund” (herein called the “Reserve Fund”); and

(iv) “City of El Paso, Texas, Water and Sewer System Improvement Fund” (herein called the “Improvement Fund”).

The Interest and Sinking Fund and the Reserve Fund shall be held in trust solely for the benefits of the Owners and the Owners of the Previously Issued Senior Lien Bonds, the Bonds and any Additional Bonds.

(b) The “City of El Paso, Texas Water and Sewer System Note Payment Fund” (the “Note Payment Fund”) heretofore created by the ordinance authorizing the City’s Commercial Paper Notes, Series A, herein referred to as the “Subordinate Lien Obligations,” is hereby reaffirmed.

Section 8.02 Revenue Fund. All Gross Revenues shall be deposited from day to day as collected into the Revenue Fund. Moneys on deposit in the Revenue Fund shall first be used to pay all Operation and Maintenance Expenses. The revenues of the System not actually required to pay Operation and Maintenance Expenses (the “Net Revenues”) shall be transferred from the Revenue Fund to the other Funds in this Ordinance, in the order of priority, in the manner, and in the amounts set forth below:

(a) Interest and Sinking Fund. In addition to the deposits required by ordinances authorizing the Previously Issued Senior Lien Bonds, there shall be deposited into the Interest and Sinking Fund the following:

(i) such amounts, in equal monthly installments, commencing on the first day of the month next following the month of Closing Date, and on the first day of each month thereafter, as will be sufficient to pay the interest scheduled to come due on the Bonds on the next interest payment date, less any amounts already on deposit therein for such purpose derived from the proceeds of the Bonds or from any other lawfully available source; and

(ii) such amounts, in equal monthly installments, commencing on the first day of the month next following the month of Closing Date, and on the first day of each month thereafter, as will be sufficient to pay the next maturing principal of the Bonds, including any scheduled mandatory redemption of Bonds.

The Interest and Sinking Fund shall be used to pay the principal of and interest on the Bonds, the Previously Issued Senior Lien Bonds and any Additional Bonds as such principal matures and such interest becomes due.

(b) Reserve Fund. So long as the funds on deposit in the Reserve Fund created for the benefit of the Bonds, the Previously Issued Senior Lien Bonds, and all Additional Bonds are equal to the Reserve Fund Requirement, no deposits need to be made to the credit of the Reserve Fund; but should the Reserve Fund at any time contain less than the Reserve Fund Requirement, then, subject and subordinate to making the required deposits to the credit of the Interest and Sinking Fund, the City shall transfer from the Net Revenues in the Revenue Fund and deposit to the credit of the Reserve Fund, on the first day of each month, such amounts in equal monthly installments to accumulate within at least five years and one month a sum equal to the Reserve Fund Requirement. The money on deposit in the Reserve Fund may be used to pay the principal of and interest on the Bonds, the Previously Issued Senior Lien Bonds and any Additional Bonds at any time there are not sufficient funds on deposit in the Interest and Sinking Fund for such purpose.

In accordance with the procedures specified in the preceding paragraph, the City hereby directs that the deposits, if any, being made to the Reserve Fund be increased to accumulate in the Reserve Fund within five years and one month from the date of the Bonds an amount equal to the Reserve Fund Requirement.

(c) Note Payment Fund. In addition to the foregoing deposits, in order to provide for the payment of and security for any Subordinate Lien Obligations there shall be deposited to the Note Payment Fund amounts sufficient to pay when due the principal of and interest on the Subordinate Lien Obligations.

(d) Payment to the City's General Fund. At the end of each month there shall be paid to the City Treasurer for deposit to the City's General Fund from any money which may remain in the Revenue Fund after all payments required to be paid from such Fund in such month have been made and all deficiencies accumulated from prior months have been remedied, such amounts as will result in there having been paid to the City during each fiscal year, ten percent (10%) of the total received by the Board from the sale of water during the fiscal year.

(e) Improvement Fund. All money remaining in the Revenue Fund at the end of each month after all payments required to be made therefrom in such month have been made and all deficiencies accumulated from prior months have been remedied shall continue to be paid to the Improvement Fund established in connection with the System, and shall be held in and paid out from such Fund for the following purposes:

(i) To pay the cost of any special or extraordinary repairs or replacements to or of the properties comprising the System, properly payable with such money under the laws of the State of Texas, necessitated by reason of some emergency; and

(ii) To the extent permitted by law, for the making of extensions, improvements, and betterments of the System.

Section 8.03 Investment of Funds.

(a) Revenue Fund and Interest and Sinking Fund. The Funds hereinabove created shall be invested and secured in the manner required by State or federal law, including specifically the Public Funds Investment Act, Texas Government Code, Chapter 2256, as appropriate. Moneys on deposit in the Interest and Sinking Fund and the Revenue Fund shall be continually secured by the deposit of collateral securities having a market value at all times not less than the amount in such Fund. The money in the Interest and Sinking Fund and the Reserve Fund shall be held as a trust fund for the benefit of the Owners of the Bonds, the Previously Issued Senior Lien Bonds and any Additional Bonds, the beneficial interest in which shall be regarded as existing in such owners. The Secretary of the Board shall require arrangements to be made with the Paying Agent/Registrar as will, to the extent of money in the Interest and Sinking Fund, and, if necessary, in the Reserve Fund, assure the prompt payment of principal of and interest on the Bonds herein authorized as such principal and interest become due, except that by agreement with the Owners of any Bonds purchased on the open market for retirement, payment of principal and interest thereon due by reason of such purchase, may be made by the Paying Agent/Registrar to the Owners thereof upon surrender of Bonds. All Bonds so paid, redeemed or purchased shall be canceled and shall not be subject to reissuance.

(b) Investment of Reserve Fund. To the extent permitted by applicable law, including specifically the Public Funds Investment Act, Texas Government Code, Chapter 2256, as amended, moneys on deposit in the Reserve Fund may be invested and reinvested in direct obligations of, or obligations the principal of and the interest on which are unconditionally guaranteed by the United States Government, Federal Intermediate Credit Banks, Federal Land Banks, Federal National Mortgage Association, Federal Home Loan Banks, Banks for Cooperatives, or certificates of deposit, the payment of which are insured in full by the Federal Deposit Insurance Corporation or the Federal Savings and Loan Insurance Corporation, which shall mature, or which shall be subject to redemption by the Owner thereof at the option of such Owner, not later than ten years after the date of investment. Any obligations in which money is so invested shall be kept in escrow and shall be promptly sold and the proceeds of sale applied to the making of payments required to be made from the Reserve Fund whenever such payments are necessary to be made under this Section. The deposits into the Reserve Fund shall be subordinate to those required to be made into the bond funds for the Previously Issued Senior Lien Bonds, the Bonds, and any Additional Bonds.

Section 8.04 Contributions in Aid of Construction. Any moneys that may be received by the Board that shall represent contributions in aid of construction shall be deposited in a separate account at the Depository Bank. Such contributions shall not be considered as part of the Gross Revenues of the System. Payments from such bank account shall be made only for the purposes for which the contributions were made, including any refunds that may become due to any contributor.

Section 8.05 Construction Fund.

(a) There is hereby established and created the “City of El Paso, Texas, Water and Sewer Revenue Bonds Construction Fund” and/or any additional or different designation as specified in the applicable Pricing Certificate (the “Construction Fund”), which shall be maintained by the Board at the Depository Bank and which shall be kept segregated and apart from other funds and accounts of the City and the Board. The amount of proceeds of sale to be deposited to the Construction Fund shall be specified in the applicable Pricing Certificate.

(b) Moneys deposited to the credit of the Construction Fund shall be invested and secured in the manner required by State or federal law, including specifically the Public Funds Investment Act, Chapter 2256, Texas Government Code, as appropriate.

ARTICLE 9

DEPOSIT OF PROCEEDS; CONTROL AND DELIVERY OF BONDS

Section 9.01 Deposit of Proceeds.

(a) All amounts, if any, received on the Closing Date as accrued interest on the Bonds shall be deposited to the Interest and Sinking Fund.

(b) Bond proceeds, less the accrued interest, if any, referenced in the preceding paragraph, amounts to pay costs of issuance and amounts to pay municipal bond insurance premium, if any, shall be deposited as provided in the applicable Pricing Certificate.

Section 9.02 Control and Delivery of Bonds.

(a) The Mayor, or in his absence, the Mayor Pro-Tem, is hereby authorized to have control of the Initial Bond and all necessary records and proceedings pertaining thereto pending investigation, examination and approval of the Attorney General of the State of Texas, registration by the Comptroller of Public Accounts of the State of Texas, and registration with, and initial exchange or transfer by, the Paying Agent/Registrar.

(b) After registration by the Comptroller of Public Accounts, delivery of the Bonds shall be made to the Purchaser under and subject to the general supervision of the City Manager of the City or the President/Chief Executive Officer of the System against receipt by the City of all amounts due the City under the terms of the sale.

ARTICLE 10

PARTICULAR REPRESENTATIONS AND COVENANTS

Section 10.01 Insurance. The City hereby agrees that it will carry at all times for the benefit of the Owners of the Bonds, such insurance on the System that is reasonably obtainable of the kinds and in the amounts which are usually carried by private companies operating similar properties. Such insurance may be provided by means of a self-insurance fund in which event deposits to such fund shall be a maintenance and operating expense of the System.

Section 10.02 Books and Records. The City hereby covenants and agrees that complete and proper books of records and account will be kept and that the Owners of any of the Bonds, or any duly authorized agent or agents of such Owners, shall have the right to inspect such records at all reasonable times. The Board will within sixty (60) days following the close of each fiscal year, cause an audit of the books and accounts to be made by an independent firm of certified public accountants and that such audit will be available for inspection by the Owners of any of the Bonds.

Section 10.03 Additional Covenants.

(a) Additional Bonds. The City may issue “Additional Bonds” if the following conditions are met:

(i) the City is not then in default as to any covenant, condition or obligation prescribed by an ordinance authorizing the issuance of any bonds payable from and secured by a first lien on and pledge of the Net Revenues;

(ii) the Additional Bonds are made to mature on March 1 or September 1 in each of the years in which they are scheduled to mature;

(iii) the net earnings of the System for any consecutive period of 12 months of the 15 months next preceding the month of the date of the Additional Bonds then to be issued, or for the City’s completed fiscal year next preceding the date of such Additional Bonds, are equal to at least 1.25 times the maximum annual principal and interest requirements of all bonds to be outstanding after the issuance of the Additional Bonds, as such net earnings are shown by a report by a certified public accountant; and

(iv) the amount to be accumulated and maintained in the Reserve Fund shall be increased to an amount not less than the average annual requirements for the payment of principal of and interest on the Bonds, the Previously Issued Senior Lien Bonds and the Additional Bonds, such additional amount to be accumulated in equal monthly installments during a period not to exceed five years and one month.

(b) Maintain and Operate System Efficiently. The City and the Board hereby covenant, respectively, that they will maintain and operate the System with all possible efficiency while any of the Bonds remain outstanding and faithfully and punctually perform all duties with reference to the System required by the Constitution and laws of the State.

(c) Rate Covenant. The Board hereby covenants that it will establish and maintain rates for water and sewer services supplied by the System which shall produce or yield revenues sufficient to pay maintenance and operating expenses of the System and an additional amount equal to 150% of the aggregate amount required to be paid in such year for principal and interest on all outstanding Previously Issued Senior Lien Bonds, the Bonds, and any Additional Bonds.

(d) Charges for Water and Sewer Service. The City and the Board hereby covenant that charges for sewer services will be made jointly with charges made for the sale of water and water services. Such charges shall be required to be paid by the customer at the same time. Water connections shall be permitted only on a metered basis.

(e) Enforcement.

(i) The City and the Board hereby respectively covenant, acting in the exercise of their respective police powers, to take all necessary action to require every owner, tenant or occupant of each lot or parcel of land in the City which abuts upon a street or other public way containing a sewer line and upon which lot or parcel a building shall have been constructed for residential, commercial or industrial use to connect such building with the System and to cease using any other method for the disposal of sewage, sewage waste or other polluting matter. All such connections shall be made in accordance with the rules and regulations of the City and the Board, as may be adopted from time to time, which rules and regulations may provide for an inspection charge to assure the proper making of such connections.

(ii) The City and the Board hereby further covenant, respectively, to require the occupant of any premises, the owner or occupant of which shall be delinquent for more than thirty (30) days in the payment of sewer charges imposed hereunder, to cease to dispose of sewage or industrial or commercial wastes originating from or on such premises by discharge thereof into the System until such delinquent charges, together with all penalties relating thereto, shall have been paid. In order to enforce the provisions of this covenant and to prevent the creation of a health hazard, in the event any such occupant shall not cease such disposal, the supply and sale of water to such premises shall cease until such time as all delinquencies have been removed.

(iii) The Board will proceed immediately with a suit in assumpsit or similar action against such owner or occupant to recover the amount of any delinquent charges, together with penalties and with interest computed thereon at the rate of six percent (6%) per annum.

(iv) The Board will shut off the supply of water to any premises the owner or occupant of which shall be delinquent for more than thirty (30) days in the payment of any charges imposed hereunder.

(f) Nonimpairment of Lien. The City and the Board hereby covenant, respectively, to take no action or omit to take any action, or suffer to be done or omitted to be done, any matter or thing whatsoever whereby the lien of the Bonds, the Previously Issued Senior Lien Bonds and any Additional Bonds on the revenues of the System might or could be lost or impaired, and that the Board will pay or cause to be paid, or will make adequate provision for the satisfaction and discharge of all lawful claims and demands for labor, materials, supplies, or other objects which, if unpaid, might by law be given precedence to, or an equality with the Bonds, the Previously Issued Senior Lien Bonds and any Additional Bonds as a lien or charge upon the revenues of the System or any part thereof; provided that nothing in this subsection (f) shall be construed to require the Board to pay, discharge or make provision for any such lien, charge, claim or demand so long as the validity thereof shall be by it in good faith contested.

(g) No Sale or Encumbrance of System. The City and the Board hereby covenant, respectively, that they will not in any manner dispose of the System or any substantial part thereof, including any and all extensions and additions that may be made thereto, until the Bonds, the Previously Issued Senior Lien Bonds and any Additional Bonds shall have been paid in full as to both principal and interest; provided, however, that this covenant shall not be construed to prevent



the disposal by the City of property, which in the Board's judgment has become inexpedient to use in connection with the System, when other property of equal value is substituted therefor or when the proceeds of such disposition of such property are placed in the Interest and Sinking Fund, in addition to all other amounts required to be placed in the Interest and Sinking Fund in the current fiscal year, and are used for the retirement of Bonds, Previously Issued Senior Lien Bonds, and any Additional Bonds in advance of their respective maturities.

(h) Payment to City from Sale of Land. An amount equal to five percent (5%) of the net proceeds from the sale of lands of the System shall be paid as received to the General Fund of the City and used for any lawful purpose.

(i) No Competing Systems. The City hereby covenants that it will not grant a franchise for the operation of any competing water or sewer system in the City until all Bonds, Previously Issued Senior Lien Bonds and any Additional Bonds have been paid in full with respect to principal and interest.

(j) No Free Service. The Board hereby covenants that it will not permit free water or services to be supplied to the City or to any other user, and the City hereby agrees that it will pay from its general fund the reasonable value of all water and services obtained from the System by the City and all departments and agencies thereof.

#### Section 10.04 Covenants to Maintain Tax Exempt Status.

(a) Definitions. When used in this Section, the following terms shall have the following meanings:

“Closing Date” means the date on which the Bonds are first authenticated and delivered to the initial purchasers against payment therefor.

“Code” means the Internal Revenue Code of 1986, as amended by all legislation, if any, effective on or before the Closing Date.

“Computation Date” has the meaning set forth in Section 1.148-1(b) of the Regulations.

“Gross Proceeds” means any proceeds as defined in Section 1.148-1(b) of the Regulations, and any replacement proceeds as defined in Section 1.148-1(c) of the Regulations, of the Bonds.

“Investment” has the meaning set forth in Section 1.148-1(b) of the Regulations.

“Nonpurpose Investment” means any investment property, as defined in Section 148(b) of the Code, in which Gross Proceeds of the Bonds are invested and which is not acquired to carry out the governmental purposes of the Bonds.

“Rebate Amount” has the meaning set forth in Section 1.148-1(b) of the Regulations.

“Regulations” means any proposed, temporary, or final Income Tax Regulations issued pursuant to Sections 103 and 141 through 150 of the Code, and 103 of the Internal Revenue Code of 1954, which are applicable to the Bonds. Any reference to any specific Regulation shall also

mean, as appropriate, any proposed, temporary or final Income Tax Regulation designed to supplement, amend or replace the specific Regulation referenced.

“Yield” of (1) any Investment has the meaning set forth in Section 1.148-5 of the Regulations and (2) the Bonds has the meaning set forth in Section 1.148-4 of the Regulations.

(b) Not to Cause Interest to Become Taxable. The City shall not use, permit the use of, or omit to use Gross Proceeds or any other amounts (or any property the acquisition, construction or improvement of which is to be financed directly or indirectly with Gross Proceeds) in a manner which, if made or omitted, respectively, would cause interest on any Bond issued hereunder to become includable in the gross income, as defined in Section 61 of the Code, of the owner thereof for federal income tax purposes. Without limiting the generality of the foregoing, unless and until the City receives a written opinion of counsel nationally recognized in the field of municipal bond law to the effect that failure to comply with such covenant will not adversely affect the exemption from federal income tax of the interest on any Bond, the City shall comply with each of the specific covenants in this Section.

(c) No Private Use or Private Payments. Except as permitted by Section 141 of the Code and the Regulations and rulings thereunder, the City shall at all times prior to the last stated maturity of the Bonds:

(i) exclusively own, operate and possess all property the acquisition, construction or improvement of which is to be financed or refinanced directly or indirectly with Gross Proceeds of the Bonds (including property financed with Gross Proceeds of the Refunded Commercial Paper Notes), and not use or permit the use of such Gross Proceeds (including all contractual arrangements with terms different than those applicable to the general public) or any property acquired, constructed or improved with such Gross Proceeds in any activity carried on by any person or entity (including the United States or any agency, department and instrumentality thereof) other than a state or local government, unless such use is solely as a member of the general public; and

(ii) not directly or indirectly impose or accept any charge or other payment by any person or entity who is treated as using Gross Proceeds of the Bonds (including property financed with Gross Proceeds of the Refunded Commercial Paper Notes) or any property the acquisition, construction or improvement of which is to be financed or refinanced directly or indirectly with such Gross Proceeds, other than taxes of general application within the City or interest earned on investments acquired with such Gross Proceeds pending application for their intended purposes.

(d) No Private Loan. Except to the extent permitted by Section 141 of the Code and the Regulations and rulings thereunder, the City shall not use Gross Proceeds of the Bonds to make or finance loans to any person or entity other than a state or local government. For purposes of the foregoing covenant, such Gross Proceeds are considered to be “loaned” to a person or entity if: (1) property acquired, constructed or improved with such Gross Proceeds is sold or leased to such person or entity in a transaction which creates a debt for federal income tax purposes; (2) capacity in or service from such property is committed to such person or entity under a take or pay, output or similar contract or arrangement; or (3) indirect benefits, or burdens and benefits of ownership,

of such Gross Proceeds or any property acquired, constructed or improved with such Gross Proceeds are otherwise transferred in a transaction which is the economic equivalent of a loan.

(e) Not to Invest at Higher Yield. Except to the extent permitted by Section 148 of the Code and the Regulations and rulings thereunder, the City shall not at any time prior to the final stated maturity of the Bonds directly or indirectly invest Gross Proceeds in any Investment (or use Gross Proceeds to replace money so invested), if as a result of such investment the Yield from the Closing Date of all Investments acquired with Gross Proceeds (or with money replaced thereby), whether then held or previously disposed of, exceeds the Yield of the Bonds.

(f) Not Federally Guaranteed. Except to the extent permitted by Section 149(b) of the Code and the Regulations and rulings thereunder, the City shall not take or omit to take any action which would cause the Bonds to be federally guaranteed within the meaning of Section 149(b) of the Code and the Regulations and rulings thereunder.

(g) Information Report. The City shall timely file the information required by section 149(e) of the Code with the Secretary of the Treasury on Form 8038-G or such other form and in such place as the Secretary may prescribe.

(h) Rebate of Arbitrage Profits. Except to the extent otherwise provided in Section 148(f) of the Code and the Regulations and rulings thereunder:

(i) The City shall account for all Gross Proceeds (including all receipts, expenditures and investments thereof) on its books of account separately and apart from all other funds (and receipts, expenditures and investments thereof) and shall retain all records of accounting for at least six years after the day on which the last Outstanding Bond is discharged. However, to the extent permitted by law, the City may commingle Gross Proceeds of the Bonds with other money of the City, provided that the City separately accounts for each receipt and expenditure of Gross Proceeds and the obligations acquired therewith.

(ii) Not less frequently than each Computation Date, the City shall calculate the Rebate Amount in accordance with rules set forth in Section 148(f) of the Code and the Regulations and rulings thereunder. The City shall maintain such calculations with its official transcript of proceedings relating to the issuance of the Bonds until six years after the final Computation Date.

(iii) As additional consideration for the purchase of the Bonds by the Purchaser and the loan of the money represented thereby and in order to induce such purchase by measures designed to insure the excludability of the interest thereon from the gross income of the owners thereof for federal income tax purposes, the City shall pay to the United States out of the Interest and Sinking Fund or its general fund, as permitted by applicable Texas statute, regulation or opinion of the Attorney General of the State of Texas, the amount that when added to the future value of previous rebate payments made for the Bonds equals (i) in the case of a Final Computation Date as defined in Section 1.148-3(e)(2) of the Regulations, one hundred percent (100%) of the Rebate Amount on such date; and (ii) in the case of any other Computation Date, ninety percent (90%) of the Rebate Amount on such date. In all cases, the rebate payments shall be made at the times, in the

installments, to the place and in the manner as is or may be required by Section 148(f) of the Code and the Regulations and rulings thereunder, and shall be accompanied by Form 8038-T or such other forms and information as is or may be required by Section 148(f) of the Code and the Regulations and rulings thereunder.

(iv) The City shall exercise reasonable diligence to assure that no errors are made in the calculations and payments required by paragraphs (ii) and (iii), and if an error is made, to discover and promptly correct such error within a reasonable amount of time thereafter (and in all events within one hundred eighty (180) days after discovery of the error), including payment to the United States of any additional Rebate Amount owed to it, interest thereon, and any penalty imposed under Section 1.148 3(h) of the Regulations.

(i) Not to Divert Arbitrage Profits. Except to the extent permitted by Section 148 of the Code and the Regulations and rulings thereunder, the City shall not, at any time prior to the earlier of the stated maturity or final payment of the Bonds, enter into any transaction that reduces the amount required to be paid to the United States pursuant to subsection (h) of this Section because such transaction results in a smaller profit or a larger loss than would have resulted if the transaction had been at arm's length and had the Yield of the Bonds not been relevant to either party.

(j) Elections. The City hereby directs and authorizes the City Manager, the President/Chief Executive Officer of the System, the Vice President of Strategic, Financial and Management Services of the System and/or the Chief Financial Officer of the System, either or any combination of them, to make elections permitted or required pursuant to the provisions of the Code or the Regulations, as they deem necessary or appropriate in connection with the Bonds, in the Certificate as to Tax Exemption or similar or other appropriate certificate, form or document.

(k) Bonds Not Hedge Bonds. (1) At the time the original obligations refunded by the Bonds were issued, the City reasonably expected to spend at least 85% of the spendable proceeds of such original obligations within three years after such obligations were issued and (2) not more than 50% of the proceeds of the original obligations refunded by the Bonds were invested in Nonpurpose Investments having a substantially guaranteed Yield for a period of 4 years or more.

(l) Current Refunding. The payment and discharge of the Refunded Commercial Paper Notes will occur within ninety (90) days after the issuance of the Bonds and, therefore, the portion of the Bonds issued to refund such obligations are a current refunding.

Section 10.05 Continuing Obligation. Notwithstanding any other provision of this Ordinance, the City's obligations under the covenants and provisions of this Article 10 shall survive the defeasance and discharge of the Bonds.

## ARTICLE 11

### DEFAULT AND REMEDIES

Section 11.01 Remedies in Event of Default. In addition to all the rights and remedies provided by the laws of the State of Texas, the City covenants and agrees particularly that in the event the City (a) defaults in payments to be made to the Interest and Sinking Fund or the Reserve

Fund as required by the Ordinance, or (b) defaults in the observance or performance of any other of the covenants, conditions or obligations set forth in the Ordinance, the Owner or Owners of any of the Bonds shall be entitled to a writ of mandamus issued by a court of proper jurisdiction, compelling and requiring the City and its officers to observe and perform any covenant, condition or obligation prescribed in the Ordinance. No delay or omission to exercise any right or power accruing upon any default shall impair any such right or power, nor shall such delay or omission be construed to be a waiver of any such default or acquiescence therein, and every such right and power may be exercised from time to time and as often as may be deemed expedient.

Section 11.02 Remedies Not Exclusive. No remedy herein conferred or reserved is intended to be exclusive of any other available remedy or remedies, but each and every such remedy shall be cumulative and shall be in addition to every other remedy given hereunder or under the Bonds or now or hereafter existing at law or in equity; provided, however, that notwithstanding any other provision of this Ordinance, the right to accelerate the debt evidenced by the Bonds shall not be available as a remedy under this Ordinance.

The exercise of any remedy herein conferred or reserved shall not be deemed a waiver of any other available remedy.

## ARTICLE 12

### DISCHARGE

Section 12.01 Discharge. If the City shall pay or cause to be paid, or there shall otherwise be paid to the Owners, the principal of, premium, if any, and interest on the Bonds, at the times and in the manner stipulated in this Ordinance, then the pledge of Net Revenues of the System under this Ordinance and all covenants, agreements, and other obligations of the City to the Owners shall thereupon cease, terminate, and be discharged and satisfied.

Bonds or any principal amount(s) thereof shall be deemed to have been paid within the meaning and with the effective expressed in this Section when (i) money sufficient to pay in full such Bonds or the principal amount(s) thereof at maturity, together with all interest due thereon, shall have been irrevocably deposited with and held in trust by the Paying Agent/Registrar, or an authorized escrow agent or (ii) Government Obligations shall have been irrevocably deposited in trust with the Paying Agent/Registrar, or an authorized escrow agent, which Government Obligations shall mature as to principal and interest in such amounts and at such times as will insure the availability, without reinvestment, of sufficient money, together with any moneys deposited therewith, if any, to pay when due the principal of and interest on such Bonds, or the principal amount(s) thereof, on and prior to the stated maturity thereof. In the event of a defeasance of the Bonds, the City shall deliver a certificate from its financial advisor, the Paying Agent/Registrar, an independent certified public accountant, or another qualified third party concerning the sufficiency of the deposit of cash and/or Government Obligations to pay, when due, the principal of, redemption premium (if any), and interest due on any defeased Bonds. The City covenants that no deposit of moneys or Government Obligations will be made under this Section and no use will be made of any such deposit which would cause the Bonds to be treated as "arbitrage bonds" within the meaning of Section 148 of the Code or the regulations adopted pursuant thereto.

All moneys so deposited with the Paying Agent/Registrar or an authorized escrow agent, and all income from Government Obligations held in trust by the Paying Agent/Registrar, or an authorized escrow agent, and all income from Government Obligations held in trust by the Paying Agent/Registrar, or an authorized escrow agent, pursuant to this Section, which is not required for the payment of the Bonds, or any principal amount(s) thereof, or interest thereon with respect to which such moneys have been so deposited shall be remitted to the City or deposited as directed by the City. Furthermore, any money held by the Paying Agent/Registrar for the payment of the principal of and interest on the Bonds and remaining unclaimed for a period of three (3) years after the stated maturity of the Bonds such moneys were deposited and are held in trust to pay shall upon request of the City be remitted to the City against a written receipt therefor. The provisions of this paragraph are subject to the applicable unclaimed property law of the State of Texas.

The City reserves the right, subject to satisfying the requirements of (i) and (ii) above, to substitute other Government Obligations for the Government Obligations originally deposited, to reinvest the uninvested moneys on deposit for such defeasance and to withdraw for the benefit of the City moneys in excess of the amount required for such defeasance.

Upon such deposit as described above, such Bonds shall no longer be regarded to be outstanding or unpaid. Provided, however, the City has reserved the option, to be exercised at the time of the defeasance of the Bonds, to call for redemption, at an earlier date, those Bonds which have been defeased to their maturity date, if the City: (i) in the proceedings providing for the firm banking and financial arrangements, expressly reserves the right to call the Bonds for redemption; (ii) gives notice of the reservation of that right to the Owners immediately following the making of the firm banking and financial arrangements; and (iii) directs that notice of the reservation be included in any redemption notices that it authorizes.

## ARTICLE 13

### SALE AND DELIVERY OF BONDS; OFFICIAL STATEMENT

#### Section 13.01 Sale of Bonds-Official Statement.

(a) The Bonds authorized by this Ordinance are to be sold by the City to the Purchaser by (i) negotiated sale, in accordance with one or more bond purchase agreements (each, a "Purchase Contract"), (ii) private placement, in accordance with one or more agreements to purchase or other agreement, or (iii) competitive bidding, in accordance with the successful bids submitted therefor, as determined by the Pricing Officer, in accordance with Section 3.02 hereof. In the event the Bonds are sold by negotiated sale, the Pricing Officer shall designate and identify the Purchaser in the applicable Pricing Certificate. The Pricing Officer is hereby authorized and directed to execute the Purchase Contract, agreement to purchase in the event of a private placement, or the successful bid form in the event of a competitive sale, as applicable, for and on behalf of the City and as the act and deed of this City Council.

The Mayor and City Clerk of the City are further authorized and directed to manually or electronically execute and deliver for and on behalf of the City copies of a Preliminary Official Statement and Official Statement, prepared in connection with the offering of the Bonds by the Purchaser, in final form as may be required by the Purchaser, and such final Official Statement in

the form and content as approved by the Pricing Officer or as manually or electronically executed by such officials shall be deemed to be approved by the City Council of the City and constitute the Official Statement authorized for distribution and use by the Purchaser.

(b) The City Manager, the President/Chief Executive Officer of the System, the Vice President of Strategic, Financial and Management Services of the System, the Chief Financial Officer of the System or any other officer of the City are each authorized to execute such documents, certificates and receipts, and to make such elections with respect to the tax-exempt status of the Bonds, as they may deem appropriate in order to consummate the delivery of the Bonds in accordance with the provisions and terms of this Ordinance and the Pricing Certificate.

(c) The obligation of the Purchaser to accept delivery of the Bonds is subject to the Purchaser being furnished with the final, approving opinion of Norton Rose Fulbright US LLP as Bond Counsel for the City, which opinion shall be dated and delivered the Closing Date. The prior engagement of such firm as Bond Counsel to the City in connection with the issuance of its System revenue bonds is hereby approved and confirmed.

## ARTICLE 14

### CONTINUING DISCLOSURE UNDERTAKING

#### Section 14.01 Annual Reports.

(a) The City shall cause the Board to provide annually to the MSRB (1) within six months after the end of each fiscal year (beginning with the fiscal year stated in the Pricing Certificate) financial information and operating data with respect to the System of the general type included in the final Official Statement approved by the Pricing Officer and described in the Pricing Certificate, and (2) if not provided as part of such financial information and operating data, audited financial statements of the System, when and if available, and in any case within 12 months after the end of each fiscal year (beginning with the fiscal year stated in the Pricing Certificate). Any financial statements so to be provided shall be prepared in accordance with the accounting principles described in the Pricing Certificate, or such other accounting principles as the Board may be required to employ from time to time pursuant to state law or regulation, and audited, if the Board commissions an audit of such statements and the audit is completed within the period during which they must be provided. If audited financial statements are not available by the required time, the Board will provide unaudited financial statements by the required time and audited financial statements when and if such audited financial statements become available.

(b) If the Board changes its fiscal year, it will notify the MSRB of the change (and of the date of the new fiscal year end) prior to the next date by which the Board otherwise would be required to provide financial information and operating data pursuant to this Article.

(c) The financial information and operating data to be provided pursuant to this Article may be set forth in full in one or more documents or may be included by specific reference to any document available to the public on the MSRB's Internet Web site or filed with the SEC.

Section 14.02 Notice of Certain Events.

(a) The City will cause the Board to provide notice of any of the following events with respect to the Bonds to the MSRB in a timely manner and not more than 10 business days after occurrence of the event:

- (i) principal and interest payment delinquencies;
- (ii) non-payment related defaults, if material;
- (iii) unscheduled draws on debt service reserves reflecting financial difficulties;
- (iv) unscheduled draws on credit enhancements reflecting financial difficulties;
- (v) substitution of credit or liquidity providers, or their failure to perform;
- (vi) adverse tax opinions, the issuance by the Internal Revenue Service of proposed or final determinations of taxability, Notices of Proposed Issue (IRS Form 5701-TEB), or other material notices or determinations with respect to the tax status of the Bonds, or other material events affecting the tax status of the Bonds;
- (vii) modifications to rights of Owners of the Bonds, if material;
- (viii) bond calls, if material, and tender offers;
- (ix) defeasances;
- (x) release, substitution, or sale of property securing repayment of the Bonds, if material;
- (xi) rating changes;
- (xii) bankruptcy, insolvency, receivership, or similar event of the Board or City, which shall occur as described below;
- (xiii) the consummation of a merger, consolidation, or acquisition involving the Board or City or the sale of all or substantially all of its assets, other than in the ordinary course of business, the entry into of a definitive agreement to undertake such an action or the termination of a definitive agreement relating to any such actions, other than pursuant to its terms, if material;
- (xiv) appointment of a successor or additional trustee or the change of name of a trustee, if material;
- (xv) incurrence of a Financial Obligation of the Board, if material, or agreement to covenants, events of default, remedies, priority rights, or other similar terms of a Financial Obligation of the Board, any of which affect security holders, if material; and
- (xvi) default, event of acceleration, termination event, modification of terms, or other similar events under the terms of a Financial Obligation of the Board, any of which reflect financial difficulties.

For these purposes, (a) any event described above in Section 14.02(a)(xii) is considered to occur when any of the following occur: the appointment of a receiver, fiscal agent, or similar officer for the Board or City in a proceeding under the United States Bankruptcy Code or in any other proceeding under state or federal law in which a court or governmental authority has assumed



jurisdiction over substantially all of the assets or business of the Board or City, or if such jurisdiction has been assumed by leaving the existing governing body and officials or officers in possession but subject to the supervision and orders of a court or governmental authority, or the entry of an order confirming a plan of reorganization, arrangement, or liquidation by a court or governmental authority having supervision or jurisdiction over substantially all of the assets or business of the Board or City, and (b) the City intends the words used in the immediately preceding subsections (a)(xv) and (a)(xvi) and the definition of Financial Obligation in this Section to have the same meanings as when they are used in the Rule, as evidenced by SEC Release No. 34-83885, dated August 20, 2018.

(b) The City hereby instructs the Board to notify the MSRB, in a timely manner, of any failure by the Board to provide financial information or operating data in accordance with this Article by the time required by this Article.

Section 14.03 Filings with the MSRB. All financial information, operating data, financial statements, notices, and other documents provided to the MSRB in accordance with this Article shall be provided in an electronic format prescribed by the MSRB and shall be accompanied by identifying information as prescribed by the MSRB.

Section 14.04 Limitations, Disclaimers and Amendments.

(a) The City, acting through the Board, shall be obligated to observe and perform the covenants specified in this Article with respect to the City, the Board and the Bonds while, but only while, the City or the Board remains an “obligated person” with respect to the Bonds within the meaning of the Rule, except that the City will cause the Board in any event to give notice required by Section 14.02 hereof of any Bond calls and defeasance that cause the City to be no longer such an “obligated person.”

(b) The provisions of this Article are for the sole benefit of the Owners and beneficial owners of the Bonds, and nothing in this Article, express or implied, shall give any benefit or any legal or equitable right, remedy, or claim hereunder to any other person. The City undertakes to provide only the financial information, operating data, financial statements, and notices which it has expressly agreed to provide pursuant to this Article and does not hereby undertake to provide any other information that may be relevant or material to a complete presentation of the financial results, condition, or prospects of the City or the State of Texas or hereby undertake to update any information provided in accordance with this Article or otherwise, except as expressly provided herein. The City does not make any representation or warranty concerning such information or its usefulness to a decision to invest in or sell Bonds at any future date.

UNDER NO CIRCUMSTANCES SHALL THE CITY BE LIABLE TO THE OWNER OR BENEFICIAL OWNER OF ANY BOND OR ANY OTHER PERSON, IN CONTRACT OR TORT, FOR DAMAGES RESULTING IN WHOLE OR IN PART FROM ANY BREACH BY THE BOARD OR THE CITY, WHETHER NEGLIGENT OR WITHOUT FAULT ON ITS PART, OF ANY COVENANT SPECIFIED IN THIS ARTICLE, BUT EVERY RIGHT AND REMEDY OF ANY SUCH PERSON, IN CONTRACT OR TORT, FOR OR ON ACCOUNT OF ANY SUCH BREACH SHALL BE LIMITED TO AN ACTION FOR MANDAMUS OR SPECIFIC PERFORMANCE.

(c) No default by the Board or the City in observing or performing its obligations under this Article shall constitute a breach of or default under this Ordinance for purposes of any other provision of this Ordinance.

(d) Nothing in this Article is intended or shall act to disclaim, waive, or otherwise limit the duties of the Board or the City under federal and state securities laws.

(e) Notwithstanding anything herein to the contrary, the provisions of this Article may be amended by the City from time to time to adapt to changed circumstances resulting from a change in legal requirements, a change in law, or a change in the identity, nature, status, or type of operations of the City or the Board, but only if (1) the provisions of this Article, as so amended, would have permitted an underwriter to purchase or sell Bonds in the primary offering of the Bonds in compliance with the Rule, taking into account any amendments or interpretations of the Rule to the date of such amendment, as well as such changed circumstances, and (2) either (a) the Owners of a majority in aggregate principal amount (or any greater amount required by any other provision of this Order that authorizes such an amendment) of the Outstanding Bonds consent to such amendment or (b) a Person that is unaffiliated with the City (such as nationally recognized bond counsel) determines that such amendment will not materially impair the interests of the Owners and beneficial owners of the Bonds. The provisions of this Article may also be amended from time to time or repealed by the City if the SEC amends or repeals the applicable provisions of the Rule or a court of final jurisdiction determines that such provisions are invalid, but only if and to the extent that reservation of the City's right to do so would not prevent underwriters of the initial public offering of the Bonds from lawfully purchasing or selling Bonds in such offering. If the City so amends the provisions of this Article, it shall include with any amended financial information or operating data next provided in accordance with subsection (b) an explanation, in narrative form, of the reasons for the amendment and of the impact of any change in the type of financial information or operating data so provided.

## ARTICLE 15

### PAYMENT OF REFUNDED COMMERCIAL PAPER NOTES.

Section 15.01 Payment of Refunded Commercial Paper Notes. Following the deposit of funds to the credit of the Note Payment Fund or otherwise as specified in the Pricing Certificate, the Refunded Commercial Paper Notes shall be payable solely from and secured by such deposits and shall cease to be payable from Net Revenues.

Section 15.02 Escrow Agreement. If required in connection with the refunding of the Refunded Commercial Paper Notes, the Pricing Officer is authorized to select and appoint an escrow agent for the refunding of the Refunded Commercial Paper Notes, and any escrow agent so selected and appointed shall be designated in the Pricing Certificate. An Escrow Agreement by and between the City and an authorized escrow agent, if any such agreement is required in connection with the refunding of the Refunded Commercial Paper Notes, shall be attached to, and approved in, the Pricing Certificate. Such Escrow Agreement is hereby authorized to be finalized and executed by the Pricing Officer for and on behalf of the City and as the act and deed of this City Council; and any such Escrow Agreement as executed by the Pricing Officer shall be deemed approved by the City Council and constitute the Escrow Agreement herein approved.

## ARTICLE 16

### MISCELLANEOUS

#### Section 16.01 Amendment to Ordinance.

(a) Amendments Without Consent. This Ordinance, the Pricing Certificate and the rights and obligations of the City and of the owners of the Bonds may be modified or amended at any time without notice to or the consent of any owner of the Bonds or any other Previously Issued Senior Lien Bonds, solely for any one or more of the following purposes:

(i) To add to the covenants and agreements of the City contained in this Ordinance or the Pricing Certificate, other covenants and agreements thereafter to be observed, or to surrender any right or power reserved to or conferred upon the City in this Ordinance or the Pricing Certificate;

(ii) To cure any ambiguity or inconsistency, or to cure or correct any defective provisions contained in this Ordinance or the Pricing Certificate, upon receipt by the City of an opinion of nationally recognized bond counsel, that the same is needed for such purpose, and will more clearly express the intent of this Ordinance or the Pricing Certificate;

(iii) To supplement the security for the Bonds, replace or provide additional credit facilities, or change the form of the Bonds or make such other changes in the provisions hereof as the City may deem necessary or desirable and which shall not, in the judgment of the City, materially adversely affect the interests of the owners of the outstanding Bonds;

(iv) To make any changes or amendments requested by any bond rating agency then rating or requested to rate Previously Issued Senior Lien Bonds, as a condition to the issuance or maintenance of a rating, which changes or amendments do not, in the judgment of the City, materially adversely affect the interests of the owners of the outstanding Previously Issued Senior Lien Bonds; or

(v) To make such other changes in the provisions hereof as the City may deem necessary or desirable and which shall not, in the judgment of the City, materially adversely affect the interests of the owners of outstanding Previously Issued Senior Lien Bonds.

Notice of any such amendment may be published by the City in the manner described in subsection (c) of this Section; provided, however, that the publication of such notice shall not constitute a condition precedent to the adoption of such amendatory resolution and the failure to publish such notice shall not adversely affect the implementation of such amendment as adopted pursuant to such amendatory resolution.

(b) Amendments With Consent. Subject to the other provisions of this Ordinance, the owners of outstanding Bonds aggregating a majority in outstanding principal amount shall have the right from time to time to approve any amendment, other than amendments described in subsection (a) of this Section, to this Ordinance or the Pricing Certificate which may be deemed necessary or desirable by the City; provided, however, that nothing herein contained shall permit or be construed to permit, without the approval of the owners of all of the outstanding Bonds, the

amendment of the terms and conditions in this Ordinance, in the Pricing Certificate or in the Bonds so as to:

- (i) Make any change in the maturity of the outstanding Bonds;
- (ii) Reduce the rate of interest borne by outstanding Bonds;
- (iii) Reduce the amount of the principal payable on outstanding Bonds;
- (iv) Modify the terms of payment of principal of or interest on the outstanding Bonds, or impose any conditions with respect to such payment;
- (v) Affect the rights of the owners of less than all Bonds then outstanding; or
- (vi) Change the minimum percentage of the outstanding principal amount of Bonds necessary for consent to such amendment.

(c) Notice. If at any time the City shall desire to amend this Ordinance or the Pricing Certificate other than pursuant to subsection (a) of this Section, the City shall cause written notice of the proposed amendment to be given by certified mail to each registered owner of the Bonds affected at the address shown on the Register. Such notice shall briefly set forth the nature of the proposed amendment and shall state that a copy thereof is on file with the City Clerk for inspection by all owners of Bonds.

(d) Consent Irrevocable. Any consent given by any owner of Bonds pursuant to the provisions of this Section shall be irrevocable for a period of eighteen (18) months from the date of mailing of the notice provided for in this Section, and shall be conclusive and binding upon all future owners of the same Bonds during such period. Such consent may be revoked at any time after eighteen (18) months from the date of mailing by the owner who gave such consent, or by a successor in title, by filing notice thereof with the Paying Agent/Registrar and the City, but such revocation shall not be effective if the owners of a majority in outstanding principal amount of Bonds, prior to the attempted revocation, consented to and approved the amendment.

(e) Ownership. For the purpose of this Section, the ownership and other matters relating to all Bonds registered as to ownership shall be determined from the registration books kept by the Paying Agent/Registrar therefor. The Paying Agent/Registrar may conclusively assume that such ownership continues until written notice to the contrary is served upon the Paying Agent/Registrar.

Section 16.02 Further Procedures. The Mayor, Mayor Pro Tem, the City Clerk, the Alternate City Clerk, the City Manager of the City, the President/Chief Executive Officer of the System, the Vice President of Strategic, Financial and Management Services of the System, and/or the Chief Financial Officer of the System and all other officers, employees and agents of the City, and each of them, shall be and they are hereby expressly authorized, empowered and directed from time to time and at any time to do and perform all such acts and things and to execute, acknowledge and deliver in the name and under the seal of the City and on behalf of the City all agreements, instruments, or such other documents, whether mentioned herein or not, as may be necessary or desirable in order to carry out the terms and provisions of this Ordinance, the initial sale and delivery of the Bonds, and the Paying Agent/Registrar Agreement. In addition, prior to the initial delivery of the Bonds, the Mayor, Mayor Pro Tem, the City Clerk, the Alternate City Clerk, the

City Manager of the City, the President/Chief Executive Officer of the System, the Vice President of Strategic, Financial and Management Services of the System or the Chief Financial Officer of the System and the City's Bond Counsel are hereby authorized and directed to approve any technical changes or corrections to this Ordinance or to any of the instruments authorized and approved by this Ordinance: (i) in order to cure any technical ambiguity, formal defect, or omission in the Ordinance or such other document; or (ii) as requested by the Attorney General or his representative to obtain the approval of the Bonds by the Attorney General and if such officer or counsel determines that such ministerial changes are consistent with the intent and purpose of the Ordinance, which determination shall be final. In the event that any officer of the City whose signature shall appear on any document shall cease to be such officer before the delivery of such document, such signature nevertheless shall be valid and sufficient for all purposes the same as if such officer had remained in office until such delivery.

Additionally, the Mayor, Mayor Pro Tem, the City Clerk, the Alternate City Clerk, the City Manager of the City, the Chief Financial Officer of the City or the Pricing Officer may execute, authenticate, certify, or endorse or authorize to be executed, authenticated, certified, or endorsed with such officer's facsimile signature instead of the officer's manual signature any written agreement, including a contract, purchase order or surety bond, and any related document, including an application, certificate, or approval. For purposes of this Ordinance, "facsimile signature" means a reproduction of the manual signature of an authorized officer that is made by any method.

Section 16.03 Municipal Bond Insurance. The Bonds may be sold with the principal of and interest thereon being insured by a municipal bond insurance provider authorized to transact business in the State of Texas. The Pricing Officer is hereby authorized to make the selection of municipal bond insurance (if any) for the Bonds and make the determination of the provisions of any commitment therefor.

Section 16.04 Effectiveness. This Ordinance shall take effect and be in force from and after its passage and approval.

[The remainder of this page intentionally left blank.]

APPROVED AND ADOPTED this \_\_\_\_ day of \_\_\_\_\_, 2022.

\_\_\_\_\_  
Oscar Leeser  
Mayor, City of El Paso, Texas

ATTEST:

\_\_\_\_\_  
Laura D. Prine  
City Clerk, City of El Paso, Texas

(SEAL)

APPROVED AS TO FORM:



\_\_\_\_\_  
Paul A. Braden  
Bond Counsel



\_\_\_\_\_  
Karla Nieman  
City Attorney  
City of El Paso, Texas

APPROVED AS TO CONTENT:



\_\_\_\_\_  
Marcela Navarrete  
Vice President, Strategic, Financial  
and Management Services  
El Paso Water Utilities

**EXHIBIT A**

**PAYING AGENT/REGISTRAR AGREEMENT**

## PAYING AGENT/REGISTRAR AGREEMENT

THIS AGREEMENT is entered into as of \_\_\_\_\_ (this "Agreement"), by and between \_\_\_\_\_, a national banking association duly organized and existing under the laws of the United States of America, or its successors (the "Bank") and the City of El Paso, Texas (the "Issuer").

### RECITALS

WHEREAS, the Issuer has duly authorized and provided for the issuance of its "City of El Paso, Texas, Water and Sewer Revenue Refunding Bonds, Series 20\_\_" (the "Securities"), dated \_\_\_\_\_, such Securities scheduled to be delivered to the initial purchasers thereof on or about \_\_\_\_\_; and

WHEREAS, the Issuer has selected the Bank to serve as Paying Agent/Registrar in connection with the payment of the principal of, premium, if any, and interest on said Securities and with respect to the registration, transfer and exchange thereof by the registered owners thereof; and

WHEREAS, the Bank has agreed to serve in such capacities for and on behalf of the Issuer and has full power and authority to perform and serve as Paying Agent/Registrar for the Securities;

NOW, THEREFORE, it is mutually agreed as follows:

### ARTICLE ONE APPOINTMENT OF BANK AS PAYING AGENT AND REGISTRAR

**Section 1.01 Appointment.** The Issuer hereby appoints the Bank to serve as Paying Agent with respect to the Securities, and, as Paying Agent for the Securities, the Bank shall be responsible for paying on behalf of the Issuer the principal, premium (if any), and interest on the Securities as the same become due and payable to the registered owners thereof; all in accordance with this Agreement and the "Authorizing Document" (hereinafter defined). The Issuer hereby appoints the Bank as Registrar with respect to the Securities and, as Registrar for the Securities, the Bank shall keep and maintain for and on behalf of the Issuer books and records as to the ownership of said Securities and with respect to the transfer and exchange thereof as provided herein and in the Authorizing Document.

The Bank hereby accepts its appointment, and agrees to serve as the Paying Agent and Registrar for the Securities.

**Section 1.02 Compensation.** As compensation for the Bank's services as Paying Agent/Registrar, the Issuer hereby agrees to pay the Bank the fees and amounts set forth in **Annex A** attached hereto; provided, however, notwithstanding anything herein or in Annex A to the contrary, the aggregate value of this agreement shall not exceed the dollar limitation set forth in Section 2271.002(a)(2) of the Texas Government Code, as amended, or Section 2274.002(a)(2) of the Texas Government Code, as amended.

In addition, the Issuer agrees to reimburse the Bank upon its request for all reasonable expenses, disbursements and advances incurred or made by the Bank in accordance with any of



the provisions hereof (including the reasonable compensation and the expenses and disbursements of its agents and counsel).

## **ARTICLE TWO DEFINITIONS**

**Section 2.01 Definitions.** For all purposes of this Agreement, except as otherwise expressly provided or unless the context otherwise requires:

“Acceleration Date” on any Security means the date, if any, on and after which the principal or any or all installments of interest, or both, are due and payable on any Security which has become accelerated pursuant to the terms of the Security.

“Authorizing Document” means the resolution, order, or ordinance of the governing body of the Issuer pursuant to which the Securities are issued, as the same may be amended or modified, including any pricing certificate related thereto, certified by the secretary or any other officer of the Issuer and delivered to the Bank.

“Bank Office” means the designated office of the Bank at the address shown in Section 3.01 hereof. The Bank will notify the Issuer in writing of any change in location of the Bank Office.

“Holder” and “Security Holder” each means the Person in whose name a Security is registered in the Security Register.

“Person” means any individual, corporation, partnership, joint venture, association, joint stock company, trust, unincorporated organization or government or any agency or political subdivision of a government.

“Predecessor Securities” of any particular Security means every previous Security evidencing all or a portion of the same obligation as that evidenced by such particular Security (and, for the purposes of this definition, any mutilated, lost, destroyed, or stolen Security for which a replacement Security has been registered and delivered in lieu thereof pursuant to Section 4.06 hereof and the Authorizing Document).

“Redemption Date”, when used with respect to any Security to be redeemed, means the date fixed for such redemption pursuant to the terms of the Authorizing Document.

“Responsible Officer”, when used with respect to the Bank, means the Chairman or Vice-Chairman of the Board of Directors, the Chairman or Vice-Chairman of the Executive Committee of the Board of Directors, the President, any Vice President, the Secretary, any Assistant Secretary, the Treasurer, any Assistant Treasurer, the Cashier, any Assistant Cashier, any Trust Officer or Assistant Trust Officer, or any other officer of the Bank customarily performing functions similar to those performed by any of the above designated officers and also means, with respect to a particular corporate trust matter, any

other officer to whom such matter is referred because of his knowledge of and familiarity with the particular subject.

“Security Register” means a register maintained by the Bank on behalf of the Issuer providing for the registration and transfers of Securities.

“Stated Maturity” means the date specified in the Authorizing Document the principal of a Security is scheduled to be due and payable.

**Section 2.02 Other Definitions.** The terms “Bank,” “Issuer,” and “Securities (Security)” have the meanings assigned to them in the recital paragraphs of this Agreement.

The term “Paying Agent/Registrar” refers to the Bank in the performance of the duties and functions of this Agreement.

**ARTICLE THREE  
PAYING AGENT**

**Section 3.01 Duties of Paying Agent.** As Paying Agent, the Bank shall pay, provided adequate collected funds have been provided to it for such purpose by or on behalf of the Issuer, on behalf of the Issuer the principal of each Security at its Stated Maturity, Redemption Date or Acceleration Date, to the Holder upon surrender of the Security to the Bank at the following address:

By Registered or Certified Mail

\_\_\_\_\_  
\_\_\_\_\_  
\_\_\_\_\_

By Hand or Overnight Mail

\_\_\_\_\_  
\_\_\_\_\_  
\_\_\_\_\_

As Paying Agent, the Bank shall, provided adequate collected funds have been provided to it for such purpose by or on behalf of the Issuer, pay on behalf of the Issuer the interest on each Security when due, by computing the amount of interest to be paid each Holder and making payment thereof to the Holders of the Securities (or their Predecessor Securities) on the Record Date (as defined in the Authorizing Document). All payments of principal and/or interest on the Securities to the registered owners shall be accomplished (1) by the issuance of checks, payable to the registered owners, drawn on the paying agent account provided in Section 5.05 hereof, sent by United States mail, first class postage prepaid, to the address appearing on the Security Register or (2) by such other method, acceptable to the Bank, requested in writing by the Holder at the Holder’s risk and expense.

**Section 3.02 Payment Dates.** The Issuer hereby instructs the Bank to pay the principal of and interest on the Securities on the dates specified in the Authorizing Document.

**ARTICLE FOUR  
REGISTRAR**

**Section 4.01 Security Register - Transfers and Exchanges.** The Bank agrees to keep and maintain for and on behalf of the Issuer at the Bank Office books and records (herein sometimes referred to as the “Security Register”) for recording the names and addresses of the Holders of the Securities, the transfer, exchange and replacement of the Securities and the payment of the principal of and interest on the Securities to the Holders and containing such other

information as may be reasonably required by the Issuer and subject to such reasonable regulations as the Issuer and the Bank may prescribe. All transfers, exchanges and replacements of Securities shall be noted in the Security Register.

Every Security surrendered for transfer or exchange shall be duly endorsed or be accompanied by a written instrument of transfer, the signature on which has been guaranteed by an officer of a federal or state bank or a member of the Financial Industry Regulatory Authority, such written instrument to be in a form satisfactory to the Bank and duly executed by the Holder thereof or his agent duly authorized in writing.

The Bank may request any supporting documentation it feels necessary to effect a re-registration, transfer or exchange of the Securities.

To the extent possible and under reasonable circumstances, the Bank agrees that, in relation to an exchange or transfer of Securities, the exchange or transfer by the Holders thereof will be completed and new Securities delivered to the Holder or the assignee of the Holder in not more than three (3) business days after the receipt of the Securities to be cancelled in an exchange or transfer and the written instrument of transfer or request for exchange duly executed by the Holder, or his duly authorized agent, in form and manner satisfactory to the Paying Agent/Registrar.

**Section 4.02 Securities.** The Issuer shall provide additional Securities when needed to facilitate transfers or exchanges thereof. The Bank covenants that such additional Securities, if and when provided, will be kept in safekeeping pending their use and reasonable care will be exercised by the Bank in maintaining such Securities in safekeeping, which shall be not less than the care maintained by the Bank for debt securities of other governments or corporations for which it serves as registrar, or that is maintained for its own securities.

**Section 4.03 Form of Security Register.** The Bank, as Registrar, will maintain the Security Register relating to the registration, payment, transfer and exchange of the Securities in accordance with the Bank's general practices and procedures in effect from time to time. The Bank shall not be obligated to maintain such Security Register in any form other than those which the Bank has currently available and currently utilizes at the time.

The Security Register may be maintained in written form or in any other form capable of being converted into written form within a reasonable time.

**Section 4.04 List of Security Holders.** The Bank will provide the Issuer at any time requested by the Issuer, upon payment of the required fee, a copy of the information contained in the Security Register. The Issuer may also inspect the information contained in the Security Register at any time the Bank is customarily open for business, provided that reasonable time is allowed the Bank to provide an up-to-date listing or to convert the information into written form.

The Bank will not release or disclose the contents of the Security Register to any person other than to, or at the written request of, an authorized officer or employee of the Issuer, except upon receipt of a court order or as otherwise required by law. Upon receipt of a court order and prior to the release or disclosure of the contents of the Security Register, the Bank will notify the Issuer so that the Issuer may contest the court order or such release or disclosure of the contents of the Security Register.

**Section 4.05 Return of Cancelled Securities.** The Bank will, at such reasonable intervals as it determines, surrender to the Issuer, all Securities in lieu of which or in exchange for which other Securities have been issued, or which have been paid.

**Section 4.06 Mutilated, Destroyed, Lost or Stolen Securities.** The Issuer hereby instructs the Bank, subject to the provisions of the Authorizing Document, to deliver and issue Securities in exchange for or in lieu of mutilated, destroyed, lost, or stolen Securities as long as the same does not result in an overissuance.

In case any Security shall be mutilated, destroyed, lost or stolen, the Bank may execute and deliver a replacement Security of like form and tenor, and in the same denomination and bearing a number not contemporaneously outstanding, in exchange and substitution for such mutilated Security, or in lieu of and in substitution for such mutilated, destroyed, lost or stolen Security, only upon the approval of the Issuer and after (i) the filing by the Holder thereof with the Bank of evidence satisfactory to the Bank of the destruction, loss or theft of such Security, and of the authenticity of the ownership thereof and (ii) the furnishing to the Bank of indemnification in an amount satisfactory to hold the Issuer and the Bank harmless. All expenses and charges associated with such indemnity and with the preparation, execution and delivery of a replacement Security shall be borne by the Holder of the Security mutilated, destroyed, lost or stolen.

**Section 4.07 Transaction Information to Issuer.** The Bank will, within a reasonable time after receipt of written request from the Issuer, furnish the Issuer information as to the Securities it has paid pursuant to Section 3.01, Securities it has delivered upon the transfer or exchange of any Securities pursuant to Section 4.01, and Securities it has delivered in exchange for or in lieu of mutilated, destroyed, lost, or stolen Securities pursuant to Section 4.06.

## **ARTICLE FIVE THE BANK**

**Section 5.01 Duties of Bank.** The Bank undertakes to perform the duties set forth herein and agrees to use reasonable care in the performance thereof.

**Section 5.02 Reliance on Documents, Etc.**

(a) The Bank may conclusively rely, as to the truth of the statements and correctness of the opinions expressed therein, on certificates or opinions furnished to the Bank.

(b) The Bank shall not be liable for any error of judgment made in good faith by a Responsible Officer, unless it shall be proved that the Bank was negligent in ascertaining the pertinent facts.

(c) No provisions of this Agreement shall require the Bank to expend or risk its own funds or otherwise incur any financial liability for performance of any of its duties hereunder, or in the exercise of any of its rights or powers, if it shall have reasonable grounds for believing that repayment of such funds or adequate indemnity satisfactory to it against such risks or liability is not assured to it.

(d) The Bank may rely and shall be protected in acting or refraining from acting upon any resolution, certificate, statement, instrument, opinion, report, notice, request, direction, consent, order, bond, note, security or other paper or document believed by it to be genuine and to have been signed or presented by the proper party or parties. Without limiting the generality

of the foregoing statement, the Bank need not examine the ownership of any Securities, but is protected in acting upon receipt of Securities containing an endorsement or instruction of transfer or power of transfer which appears on its face to be signed by the Holder or an agent of the Holder. The Bank shall not be bound to make any investigation into the facts or matters stated in a resolution, certificate, statement, instrument, opinion, report, notice, request, direction, consent, order, bond, note, security or other paper or document supplied by the Issuer.

(e) The Bank may consult with counsel, and the written advice of such counsel or any opinion of counsel shall be full and complete authorization and protection with respect to any action taken, suffered, or omitted by it hereunder in good faith and in reliance thereon.

(f) The Bank may exercise any of the powers hereunder and perform any duties hereunder either directly or by or through agents or attorneys of the Bank.

(g) The Bank is also authorized to transfer funds relating to the closing and initial delivery of the Securities in the manner disclosed in the closing memorandum or letter as prepared by the Issuer, Issuer's financial advisor or other agent. The Bank may act on a facsimile or e-mail transmission of the closing memorandum or letter acknowledged by the Issuer, the Issuer's financial advisor or other agent as the final closing memorandum or letter. The Bank shall not be liable for any losses, costs or expenses arising directly or indirectly from the Bank's reliance upon and compliance with such instructions.

**Section 5.03 Recitals of Issuer.** The recitals contained herein with respect to the Issuer and in the Securities shall be taken as the statements of the Issuer, and the Bank assumes no responsibility for their correctness.

The Bank shall in no event be liable to the Issuer, any Holder or Holders of any Security, or any other Person for any amount due on any Security from its own funds.

**Section 5.04 May Hold Securities.** The Bank, in its individual or any other capacity, may become the owner or pledgee of Securities and may otherwise deal with the Issuer with the same rights it would have if it were not the Paying Agent/Registrar, or any other agent.

**Section 5.05 Moneys Held by Bank - Paying Agent Account/Collateralization.** A paying agent account shall at all times be kept and maintained by the Bank for the receipt, safekeeping, and disbursement of moneys received from the Issuer under this Agreement for the payment of the Securities, and money deposited to the credit of such account until paid to the Holders of the Securities shall be continuously collateralized by securities or obligations which qualify and are eligible under both the laws of the State of Texas and the laws of the United States of America to secure and be pledged as collateral for paying agent accounts to the extent such money is not insured by the Federal Deposit Insurance Corporation. Payments made from such paying agent account shall be made by check drawn on such account unless the owner of the Securities shall, at its own expense and risk, request an alternative method of payment.

Subject to the applicable unclaimed property laws of the State of Texas, any money deposited with the Bank for the payment of the principal of, premium (if any), or interest on any Security and remaining unclaimed for three years after final maturity of the Security has become due and payable will be held by the Bank and disposed of only in accordance with Title 6 of the Texas Property Code, as amended. The Bank shall have no liability by virtue of actions taken in compliance with this provision.

The Bank is not obligated to pay interest on any money received by it under this Agreement.

This Agreement relates solely to money deposited for the purposes described herein, and the parties agree that the Bank may serve as depository for other funds of the Issuer, act as trustee under indentures authorizing other bond transactions of the Issuer, or act in any other capacity not in conflict with its duties hereunder.

**Section 5.06 Indemnification.** To the extent permitted by law, the Issuer agrees to indemnify the Bank for, and hold it harmless against, any loss, liability, or expense incurred without negligence or bad faith on its part, arising out of or in connection with its acceptance or administration of its duties hereunder, including the cost and expense against any claim or liability in connection with the exercise or performance of any of its powers or duties under this Agreement.

**Section 5.07 Interpleader.** The Issuer and the Bank agree that the Bank may seek adjudication of any adverse claim, demand, or controversy over its person as well as funds on deposit, in either a Federal or State District Court located in the state and county where the administrative office of the Issuer is located, and agree that service of process by certified or registered mail, return receipt requested, to the address referred to in Section 6.03 of this Agreement shall constitute adequate service. The Issuer and the Bank further agree that the Bank has the right to file a Bill of Interpleader in any court of competent jurisdiction in the State of Texas to determine the rights of any Person claiming any interest herein.

**Section 5.08 DTC Services.** It is hereby represented and warranted that, in the event the Securities are otherwise qualified and accepted for “Depository Trust Company” services or equivalent depository trust services by other organizations, the Bank has the capability and, to the extent within its control, will comply with the “Operational Arrangements”, which establishes requirements for securities to be eligible for such type depository trust services, including, but not limited to, requirements for the timeliness of payments and funds availability, transfer turnaround time, and notification of redemptions and calls.

## **ARTICLE SIX MISCELLANEOUS PROVISIONS**

**Section 6.01 Amendment.** This Agreement may be amended only by an agreement in writing signed by both of the parties hereto.

**Section 6.02 Assignment.** This Agreement may not be assigned by either party without the prior written consent of the other.

**Section 6.03 Notices.** Any request, demand, authorization, direction, notice, consent, waiver, or other document provided or permitted hereby to be given or furnished to the Issuer or the Bank shall be mailed or delivered to the Issuer or the Bank, respectively, at the addresses shown on the signature page hereof.

**Section 6.04 Effect of Headings.** The Article and Section headings herein are for convenience of reference only and shall not affect the construction hereof.

**Section 6.05 Successors and Assigns.** All covenants and agreements herein by the Issuer shall bind its successors and assigns, whether so expressed or not.

**Section 6.06 Severability.** In case any provision herein shall be invalid, illegal, or unenforceable, the validity, legality, and enforceability of the remaining provisions shall not in any way be affected or impaired thereby.

**Section 6.07 Merger, Conversion, Consolidation, or Succession.** Any corporation or association into which the Bank may be merged or converted or with which it may be consolidated, or any corporation or association resulting from any merger, conversion, or consolidation to which the Bank shall be a party, or any corporation or association succeeding to all or substantially all of the corporate trust business of the Bank shall be the successor of the Bank as Paying Agent under this Agreement without the execution or filing of any paper or any further act on the part of either parties hereto.

**Section 6.08 Benefits of Agreement.** Nothing herein, express or implied, shall give to any Person, other than the parties hereto and their successors hereunder, any benefit or any legal or equitable right, remedy, or claim hereunder.

**Section 6.09 Entire Agreement.** This Agreement and the Authorizing Document constitute the entire agreement between the parties hereto relative to the Bank acting as Paying Agent/Registrar and if any conflict exists between this Agreement and the Authorizing Document, the Authorizing Document shall govern.

**Section 6.10 Counterparts.** This Agreement may be executed in any number of counterparts, each of which shall be deemed an original and all of which shall constitute one and the same Agreement.

**Section 6.11 Termination.** This Agreement will terminate (i) on the date of final payment of the principal of and interest on the Securities to the Holders thereof or (ii) may be earlier terminated by either party upon sixty (60) days written notice; provided, however, an early termination of this Agreement by either party shall not be effective until (a) a successor Paying Agent/Registrar has been appointed by the Issuer and such appointment accepted and (b) notice has been given to the Holders of the Securities of the appointment of a successor Paying Agent/Registrar. However, if the Issuer fails to appoint a successor Paying Agent/Registrar within a reasonable time, the Bank may petition a court of competent jurisdiction within the State of Texas to appoint a successor. Furthermore, the Bank and the Issuer mutually agree that the effective date of an early termination of this Agreement shall not occur at any time which would disrupt, delay or otherwise adversely affect the payment of the Securities.

Upon an early termination of this Agreement, the Bank agrees to promptly transfer and deliver the Security Register (or a copy thereof), together with the other pertinent books and records relating to the Securities, to the successor Paying Agent/Registrar designated and appointed by the Issuer.

The provisions of Section 1.02 and of Article Five shall survive and remain in full force and effect following the termination of this Agreement.

**Section 6.12 Iran, Sudan or Foreign Terrorist Organizations.** The Bank represents that neither it nor any of its parent company, wholly- or majority-owned subsidiaries, and other affiliates is a company identified on a list prepared and maintained by the Texas Comptroller of Public Accounts under Section 2252.153 or Section 2270.0201, Texas Government Code, and posted on any of the following pages of such officer's internet website:

<https://comptroller.texas.gov/purchasing/docs/sudan-list.pdf>,  
<https://comptroller.texas.gov/purchasing/docs/iran-list.pdf>, or  
<https://comptroller.texas.gov/purchasing/docs/fto-list.pdf>.

The foregoing representation is made solely to comply with Section 2252.152, Texas Government Code, and to the extent such Section does not contravene applicable Federal law and excludes the Bank and each of its parent company, wholly- or majority-owned subsidiaries, and other affiliates, if any, that the United States government has affirmatively declared to be excluded from its federal sanctions regime relating to Sudan or Iran or any federal sanctions regime relating to a foreign terrorist organization. The Bank understands “affiliate” to mean any entity that controls, is controlled by, or is under common control with the Bank and exists to make a profit.

**Section 6.13 Governing Law.** This Agreement shall be construed in accordance with and governed by the laws of the State of Texas.

*[Remainder of page left blank intentionally.]*



IN WITNESS WHEREOF, the parties hereto have executed this Agreement as of the day and year first above written.

\_\_\_\_\_

By: \_\_\_\_\_

Title: \_\_\_\_\_

Attest:

Address: \_\_\_\_\_

\_\_\_\_\_

\_\_\_\_\_

\_\_\_\_\_

\_\_\_\_\_

Title: \_\_\_\_\_

CITY OF EL PASO, TEXAS

By: \_\_\_\_\_  
Pricing Officer

Address: El Paso Water Utilities  
1154 Hawkins Blvd.  
El Paso, Texas 79925

## ANNEX A

**EXHIBIT B**

**FORM OF BOND**

(a) Form of Bond.

REGISTERED  
No. \_\_\_\_\_

REGISTERED  
\$ \_\_\_\_\_

UNITED STATES OF AMERICA  
STATE OF TEXAS  
COUNTY OF EL PASO  
CITY OF EL PASO, TEXAS,  
WATER AND SEWER REVENUE BONDS,  
SERIES \_\_\_\_\_

INTEREST RATE: \_\_\_\_\_%      MATURITY DATE: March 1, 20\_\_      INITIAL DATE: \_\_\_\_\_, 20\_\_      CUSIP NO.: \_\_\_\_\_

The City of El Paso (the "City"), in the County of El Paso, State of Texas, for value received, hereby promises to pay to

\_\_\_\_\_

or registered assigns, but solely from the sources and in the manner hereinafter provided, on the Maturity Date specified above, the sum of

\_\_\_\_\_ DOLLARS

unless this Bond shall have been sooner called for prior redemption and the payment of the principal hereof shall have been paid or provided for, and to pay interest on such principal amount from the later of the date of delivery or the most recent interest payment date to which interest has been paid or provided for until payment of such principal amount has been paid or provided for, at the per annum rate of interest specified above, computed on the basis of a 360-day year of twelve 30-day months, such interest to be paid semiannually on March 1 and September 1 of each year, commencing \_\_\_\_\_ 1, 20\_\_. The principal of this Bond shall be payable without exchange or collection charges in lawful money of the United States of America upon presentation and surrender of this Bond at the designated payment/transfer office in Minneapolis, Minnesota (the "Designated Payment/Transfer Office") of Computershare Trust Company, N.A., Paying Agent/Registrar, or at the Designated Payment/Transfer Office of any successor thereto. Interest on this Bond is payable by check, dated as of the interest payment date, mailed by the Paying Agent/Registrar to the registered owner at the address shown on the registration books kept by the Paying Agent/Registrar or by such other customary banking arrangements acceptable to the Paying Agent/Registrar and the person to whom interest is paid; provided, however, that such person shall bear all risk and expense of such other customary banking arrangements. For the purpose of the payment of interest on this Bond, the registered owner shall be the person in whose name this Bond is registered at the close of business on the "Record Date," which shall be the fifteenth day of the month next preceding such interest payment date. In the event of a nonpayment of interest on a

scheduled payment date, and for thirty days thereafter, a new record date for such interest payment (a "Special Record Date") will be established by the Paying Agent/Registrar, if and when funds for the payment of such interest have been received from the City. Notice of the Special Record Date and of the scheduled payment date of the past due interest (which date shall be fifteen days after the Special Record Date) shall be sent at least five business days prior to the Special Record Date by United States mail, first class, postage prepaid, to the address of each owner of a Bond appearing on the books of the Paying Agent/Registrar at the close of business on the last business day next preceding the date of mailing of such notice.

If the date for the payment of the principal of or interest on this Bond shall be a Saturday, Sunday, legal holiday, or day on which banking institutions in the city where the Designated Payment/Transfer Office is located are required or authorized by law or executive order to close, the date for such payment shall be the next succeeding day which is not a Saturday, Sunday, legal holiday, or day on which banking institutions are required or authorized to close, and payment on such date shall for all purposes be deemed to have been made on the original date payment was due.

This Bond is one of a series of fully registered bonds specified in the title hereof, dated as of \_\_\_\_\_, 20\_\_, issued in the aggregate principal amount of \$\_\_\_\_\_ (herein referred to as the "Bonds"), and issued pursuant to the authority provided by Texas Government Code, Chapters 1207, 1371 and 1502, as amended, and a certain ordinance of the City (the "Ordinance"), for the purposes of (i) refunding the Refunded Commercial Paper Notes, (ii) constructing, acquiring, purchasing, renovating, enlarging, equipping, and improving System properties and facilities, and (iii) paying the costs of issuing the Bonds as described in the Ordinance. Capitalized terms used herein and not otherwise defined shall have the meaning assigned thereto in the Ordinance.

The Bonds, together with the City's previously issued and presently outstanding water and sewer senior lien revenue bonds, are payable from and secured by a first lien on and pledge of the Net Revenues of the City's combined waterworks and sewer system. The City has reserved the right, subject to the restrictions stated in the Ordinance, to issue additional revenue bonds that may be secured in the same manner and on a parity with the Bonds and the Previously Issued Senior Lien Bonds.

The City reserves the option to redeem Bonds maturing on or after March 1, 20\_\_, in whole or in part, in principal amounts of \$5,000 or any integral multiple thereof, before their respective scheduled maturity dates, on \_\_\_\_\_, 20\_\_ or on any date thereafter, at a price equal to the principal amount of the Bonds so called for redemption plus accrued interest to the redemption date. If less than all of the Bonds are to be redeemed, the City shall determine the maturity or maturities and the amounts thereof to be redeemed and shall direct the Paying Agent/Registrar to call by lot the Bonds, or portions thereof, within such maturity and in such principal amounts, for redemption.

A portion of a single Bond of a denomination greater than \$5,000 may be redeemed, but only in a principal amount equal to \$5,000 or any integral multiple thereof. If such a Bond is to be partially redeemed, the Paying Agent/Registrar shall assign a separate number for each \$5,000

portion of the Bonds and select the portion or portions of the Bond to be redeemed by lot or by any other customary method that results in a random selection.

The Bonds stated to mature on March 1, 20\_\_ and March 1, 20\_\_ (the “Term Bonds”) are subject to scheduled mandatory redemption and will be redeemed by the City, in part at a price equal to the principal amount thereof, without premium, plus accrued interest to the redemption date, out of moneys available for such purpose in the Interest and Sinking Fund, on the dates and in the respective principal amounts as set forth in the following schedule:

Term Bonds Maturing March 1, 20__	
<u>Redemption Date</u>	<u>Principal Amount</u>
March 1, 20__	\$ ,000
March 1, 20__ (maturity)	\$ ,000

Term Bonds Maturing March 1, 20__	
<u>Redemption Date</u>	<u>Principal Amount</u>
March 1, 20__	\$ ,000
March 1, 20__	\$ ,000
March 1, 20__	\$ ,000
March 1, 20__ (maturity)	\$ ,000

The Paying Agent/Registrar will select by lot or by any other customary method that results in a random selection the specific Term Bonds (or with respect to Term Bonds having a denomination in excess of \$5,000, each \$5,000 portion thereof) to be redeemed by mandatory redemption. The principal amount of Term Bonds required to be redeemed on any redemption date pursuant to the foregoing mandatory sinking fund redemption provisions hereof shall be reduced, at the option of the City, by the principal amount of any Term Bonds which, at least 45 days prior to the mandatory sinking fund redemption date (i) shall have been acquired by the City at a price not exceeding the principal amount of such Term Bonds plus accrued interest to the date of purchase thereof, and delivered to the Paying Agent/Registrar for cancellation, or (ii) shall have been redeemed pursuant to the optional redemption provisions hereof and not previously credited to a mandatory sinking fund redemption.

Notice of such redemption or redemptions shall be given by first class mail, postage prepaid, not less than 30 days before the date fixed for redemption, to the registered owner of each of the Bonds to be redeemed in whole or in part. Notice having been so given, the Bonds or portions thereof designated for redemption shall become due and payable on the redemption date specified in such notice, and from and after such date, notwithstanding that any of the Bonds or portions thereof so called for redemption shall not have been surrendered for payment, interest on such Bonds or portions thereof shall cease to accrue.

As provided in the Ordinance and subject to certain limitations therein set forth, this Bond is transferable upon surrender of this Bond for transfer at the Designated Payment/Transfer Office of the Paying Agent/Registrar with such endorsement or other evidence of transfer as is acceptable to the Paying Agent/Registrar, and, thereupon, one or more new fully registered Bonds of the same stated maturity, of authorized denominations, bearing the same rate of interest, and for the same aggregate principal amount will be issued to the designated transferee or transferees.

Neither the City nor the Paying Agent/Registrar shall be required to issue, transfer or exchange any Bond called for redemption when such redemption is to occur within 45 calendar days after the transfer or exchange date. However, such limitations of transfer shall not be applicable to an exchange by the Owner of the unredeemed balance of a Bond called for redemption in part.

With respect to any optional redemption of the Bonds, unless certain prerequisites to such redemption required by the Ordinance have been met and moneys sufficient to pay the principal of and premium, if any, and interest on the Bonds to be redeemed shall have been received by the Paying Agent/Registrar prior to the giving of such notice of redemption, such notice shall state that such redemption may, at the option of the City, be conditional upon the satisfaction of such prerequisites and receipt of such moneys by the Paying Agent/Registrar on or prior to the date fixed for such redemption, or upon any prerequisite set forth in such notice of redemption. If a conditional notice of redemption is given and such prerequisites to the redemption and sufficient moneys are not received, such notice shall be of no force and effect, the City shall not redeem such Bonds and the Paying Agent/Registrar shall give notice, in the manner in which the notice of redemption was given, to the effect that the Bonds have not been redeemed.

The City, the Paying Agent/Registrar, and any other person may treat the person in whose name this Bond is registered as the owner hereof for the purpose of receiving payment as herein provided (except interest shall be paid to the person in whose name this Bond is registered on the Record Date) and for all other purposes, whether or not this Bond be overdue, and neither the City, the Paying Agent/Registrar, nor any such agent shall be affected by notice to the contrary.

IT IS HEREBY CERTIFIED AND RECITED that this Bond has been duly and validly issued and delivered; that all acts, conditions, and things required or proper to be performed, exist, and be done precedent to or in the issuance and delivery of this Bond have been performed, existed, and been done in accordance with law; and that the interest on and principal of this Bond and the series of which it is a part, together with certain outstanding senior lien revenue bonds of the City, are secured by and payable from an irrevocable first lien on and pledge of the Net Revenues of the System, as provided in Ordinance, and not from any other revenues, funds or assets of the City.

This Bond shall not be deemed to constitute a debt of the City or a pledge of its faith and credit; nor shall the Owners hereof ever have the right to demand payment of this Bond out of any funds raised or to be raised by taxation.

IN WITNESS WHEREOF, the City has caused this Bond to be executed in its name by the manual or facsimile signature of the Mayor of the City and countersigned by the manual or facsimile signature of the City Clerk or Alternate City Clerk, and the official seal of the City has been duly impressed or placed in facsimile on this Bond.

\_\_\_\_\_  
City Clerk  
City of El Paso, Texas

\_\_\_\_\_  
Mayor  
City of El Paso, Texas

(SEAL)

(b) Form of Comptroller's Registration Certificate.

[to be printed on Initial Bond only]

OFFICE OF THE COMPTROLLER §  
OF PUBLIC ACCOUNTS § REGISTER NO. \_\_\_\_\_  
OF THE STATE OF TEXAS §

I hereby certify that there is on file and of record in my office a certificate of the Attorney General of the State of Texas to the effect that this Bond has been examined by him as required by law, that he finds that it has been issued in conformity with the Constitution and laws of the State of Texas, and that it is a valid and binding special obligation of the City of El Paso, Texas, payable from the revenues pledged to its payment by and in the ordinance authorizing same and that such Bond has this day been registered by me.

Witness my hand and seal of office at Austin, Texas, on this date: \_\_\_\_\_.

\_\_\_\_\_  
Comptroller of Public Accounts  
of the State of Texas

(SEAL)

(c) Form of Certificate of Paying Agent/Registrar.

CERTIFICATE OF PAYING AGENT/REGISTRAR

This Bond has been duly issued and registered under the provisions of the within-mentioned Ordinance; the bond or bonds of the above entitled and designated series originally delivered having been approved by the Attorney General of the State of Texas and registered by the Comptroller of Public Accounts, as shown by the records of the Paying Agent/Registrar.

The designated office of the Paying Agent/Registrar in Minneapolis, Minnesota, is the Designated Payment/Transfer Office for this Bond.

COMPUTERSHARE TRUST COMPANY,  
N.A., as Paying Agent/Registrar

Dated: \_\_\_\_\_

By: \_\_\_\_\_

Authorized Signature



(d) Form of Assignment.

ASSIGNMENT

FOR VALUE RECEIVED, the undersigned hereby sells, assigns, and transfers unto (print or typewrite name, address and Zip Code of transferee):

\_\_\_\_\_  
\_\_\_\_\_  
\_\_\_\_\_

(Social Security or other identifying number: \_\_\_\_\_) the within Bond and all rights hereunder and hereby irrevocably constitutes and appoints \_\_\_\_\_ attorney to transfer the within Bond on the books kept for registration hereof, with full power of substitution in the premises.

Dated: \_\_\_\_\_

Signature Guaranteed By:

NOTICE: The signature on this Assignment must correspond with the name of the registered owner as it appears on the face of the within Bond in every particular and must be guaranteed in a manner acceptable to the Paying Agent/Registrar.

\_\_\_\_\_  
Authorized Signatory

(e) The Initial Bond shall be in the form set forth in subsection (a) of this Exhibit, except for the following alterations:

(i) Immediately under the name of the Bond, the headings "Interest Rate" and "Maturity Date" shall be completed with the words "As Shown Below," and the heading "CUSIP No." shall be deleted.

(ii) in the first paragraph of the Bond the words "on the Maturity Date specified above, the sum of \_\_\_\_\_ DOLLARS" shall be deleted and the following will be inserted: "on March 1 in each of the years, in the principal amounts and bearing interest at the per annum rates set forth in the following schedule:

Year                      Principal Amount                      Interest Rate

(Information to be inserted from the Pricing Certificate)

(iii) the Initial Bond shall be numbered T-1.

(f) The Comptroller's Registration Certificate may be deleted from the definitive Bonds if such Certificate on the Initial Bond is fully executed.

(g) The Certificate of the Paying Agent/Registrar may be deleted from the Initial Bond if the Comptroller's Registration Certificate appears thereon.



---

File #: 22-954, Version: 1

---

**CITY OF EL PASO, TEXAS  
LEGISTAR AGENDA ITEM SUMMARY FORM**

**DISTRICT, DEPARTMENT, CONTACT INFORMATION:**

*Please choose District and Department from drop down menu. Please post exactly as example below.  
No Title's, No emails. Please use ARIAL 10 Font.*

**All Districts**

El Paso Water, Arturo Duran, (915) 594-5549

**AGENDA LANGUAGE:**

*This is the language that will be posted to the agenda. Please use ARIAL 11 Font.*

An Ordinance authorizing the issuance of "City of El Paso, Texas, Municipal Drainage Utility System Revenue Refunding Bonds, Series 2023" in an amount not to exceed \$25,330,000 to refund certain previously issued obligations of the City; and resolving matters which are necessary to effect such issuance, including the delegation of matters relating to the sale and issuance of the bonds to an authorized City officer or employee within certain specified parameters.

**CITY OF EL PASO, TEXAS**  
**AGENDA ITEM DEPARTMENT HEAD'S SUMMARY FORM**

**DEPARTMENT:** El Paso Water Utilities Public Service Board

**AGENDA DATE:** Introduction and Public Hearing- August 2, 2022

**CONTACT PERSON/PHONE:** Art Duran, El Paso Water Utilities Chief Financial Officer  
(915) 594-5549

**DISTRICT(S) AFFECTED:** All Districts

**SUBJECT: APPROVE the following Ordinance**

An Ordinance authorizing the issuance of “City of El Paso, Texas, Municipal Drainage Utility System Revenue Refunding Bonds, Series 2023” in an amount not to exceed \$25,330,000 to refund certain previously issued obligations of the City; and resolving matters which are necessary to effect such issuance, including the delegation of matters relating to the sale and issuance of the bonds to an authorized City officer or employee within certain specified parameters. (**All Districts**) [Arturo Duran, El Paso Water (915) 594-5549][Public Hearing Date: August 2, 2022]

**BACKGROUND / DISCUSSION:**

EPWater is requesting the City Council of the City of El Paso to authorize the issuance of up to \$25,330,000 of “City of El Paso, Texas, Municipal Drainage Utility System Revenue Refunding Bonds, Series 2023.”

EPWater finds that it is in the best interest of the ratepayers to pursue this financing.

**PRIOR COUNCIL ACTION:**

**Has the Council previously considered this item or a closely related one?**

Yes, on April 26, 2022, City Council approved the issuance of up to \$25,330,000 of “City of El Paso, Texas, Municipal Drainage Utility System Revenue Refunding Bonds, Series 2022A” by Ordinance date April 26, 2022; and authorize the signature of all related documents necessary to effectuate the issuance.

**AMOUNT AND SOURCE OF FUNDING:**

This item will be funded through the sale of City of El Paso, Texas Municipal Drainage Utility System Revenue Bonds, Series 2023.

**BOARD / COMMISSION ACTION:**

The El Paso Water Utilities Public Service Board approved a Resolution on July 14, 2022, requesting the City Council to authorize the issuance of up to of up to \$25,330,000 of City of El Paso, Texas Municipal Drainage Utility System Revenue Refunding Bonds, to pay off \$25,000,000 in Direct Funded Revolving Loan Notes and fund interest and related transaction costs, provided that certain parameters are met.

**AFTER EXECUTION OF ALL DOCUMENTS, PLEASE CONTACT ART DURAN TO PICK UP THE DOCUMENTS AT (915) 594-5549. THANK YOU.**



**TO:** Tomás González, City Manager, The City of El Paso, Texas

**FROM:** Art Duran, Utility Chief Financial Officer  
El Paso Water Utilities Public Service Board

**DATE:** July 22, 2022

**SUBJECT:** Request to place the following items on **Regular City Council Agenda for August 2, 2022:**

**Item (1). Ordinance Introduction and Public Hearing: City of El Paso, Texas, Water and Sewer Revenue Bonds, in one or more series.**

**Item (2). Ordinance Introduction and Public Hearing: City of El Paso, Texas, Municipal Drainage Utility System Revenue Refunding Bonds, Series 2023.**

*Agenda Posting Language for Item 1:*

An Ordinance authorizing the issuance of City of El Paso, Texas, Water and Sewer Revenue Bonds, in one or more series, in an aggregate amount not to exceed \$441,000,000 for System improvements and to refund certain obligations issued for System improvements; and resolving matters which are necessary to effect such issuance, including the delegation of matters relating to the sale and issuance of the bonds to an authorized City officer or employee within certain specified parameters. (All Districts) [Arturo Duran, El Paso Water (915) 594-5549][Public Hearing Date: August 2, 2022]

*Agenda Posting Language for Item 2:*

An Ordinance authorizing the issuance of “City of El Paso, Texas, Municipal Drainage Utility System Revenue Refunding Bonds, Series 2023” in an amount not to exceed \$25,330,000 to refund certain previously issued obligations of the City; and resolving matters which are necessary to effect such issuance, including the delegation of matters relating to the sale and issuance of the bonds to an authorized City officer or employee within certain specified parameters. (All Districts) [Arturo Duran, El Paso Water (915) 594-5549][Public Hearing Date: August 2, 2022]

\*\*\*\*\*

These two agenda items requested to be posted on the City Council’s August 2, 2022, City Council Agenda, is pursuant to separate Resolutions of El Paso Water Utilities Public Service Board (PSB) approved at the PSB’s July 13, 2022, meeting, requesting the following:

- (1) Resolution requesting the City Council to authorize the issuance of up to \$25,330,000 of City of El Paso, Texas Municipal Drainage Utility System Revenue Refunding Bonds, to pay off \$25,000,000 in Direct Funded Revolving Loan Notes and fund interest and related transaction costs, provided that certain parameters are met.

(2) Resolution requesting that the City Council authorize the issuance of up to \$441,000,000 of City of El Paso, Texas Water and Sewer Revenue Improvement and/or Refunding Bonds to pay off up to \$240,000,000 in commercial paper notes, fund approximately \$193,154,000 of Capital Improvement Program Projects approved for Fiscal Year 2022-2023, and approximately \$7,846,000 to fund related transaction costs, provided that certain parameters are met.

If there are any questions, please call me directly at (915) 594-5549 or email me at [ADuran@epwater.org](mailto:ADuran@epwater.org) or contact General Counsel, Daniel Ortiz at (915) 594-5607.

Thank you for your attention to this matter.

Attachments: Department Head Summary Forms  
PSB July 13, 2022, Resolutions  
Proposed City Council Ordinances  
City Council Presentations

cc: The Honorable Mayor Oscar Leeser (email)  
Estrella Escobar, Chief of Staff, Mayor (email)  
Robert Cortinas, Deputy City Manager and CFO (email)  
  
Karla Nieman, City Attorney (email)  
Juan Gonzalez, Senior Assistant City Attorney (email)  
Laura D. Prine, City Clerk (email)

John Balliew, P.E., President/CEO EPWU-PSB (email)  
Claudia Duran, Executive Assistant to President/CEO (email)  
Marcela Navarrete, C.P.A, Vice President-Strategic Financial &  
Management Services (email)  
  
Daniel Ortiz, General Counsel (email)  
Paul Braden, Norton, Rose, Fulbright, Bond Counsel (email)  
Maria Urbina, HTS (email)

## RESOLUTION

A RESOLUTION REQUESTING THAT THE EL PASO CITY COUNCIL AUTHORIZE THE ISSUANCE OF UP TO \$25,330,000 OF CITY OF EL PASO, TEXAS, MUNICIPAL DRAINAGE UTILITY SYSTEM REVENUE REFUNDING BONDS TO PAY OFF \$25,000,000 IN DIRECT FUNDED REVOLVING LOAN NOTES, AND FUND INTEREST AND RELATED TRANSACTION COSTS, PROVIDED THAT CERTAIN PARAMETERS ARE MET.

WHEREAS, on June 19, 2007, the City Council of the City of El Paso, Texas established the El Paso Texas Municipal Drainage Utility System by Ordinance Number 016668 for the management and control of stormwater drainage and infrastructure; and,

WHEREAS, the El Paso City Council, as authorized by State law, vested the complete authority and control of the management and operation of the El Paso Texas Municipal Drainage Utility System in the El Paso Water Utilities Public Service Board (the "Public Service Board"); and,

WHEREAS, the Public Service Board hereby finds and determines that it is in the best interests of the City to issue the City of El Paso, Texas, Municipal Drainage Utility System Revenue Refunding Bonds (the "Bonds") in order to pay off \$25,000,000 in Municipal Drainage Utility System Tax-Exempt Revolving Notes, Series A (the "Notes") issued pursuant to the "City of El Paso, Texas Municipal Drainage Utility System Revolving Note Private Placement Program"; and,

WHEREAS, the Public Service Board is requesting that the El Paso City Council approve the issuance of up to \$25,330,000 of Bonds to pay off the Notes and fund related transaction costs.

**NOW, THEREFORE, BE IT RESOLVED BY THE PUBLIC SERVICE BOARD OF THE CITY OF EL PASO, TEXAS:**

**Section 1.** That the findings and recitations set out in the preamble to this Resolution are found to be true and correct and are hereby adopted by the El Paso Water Utilities Public Service Board, which has been vested with complete authority and control of the management and operation of the Municipal Drainage Utility System, and made a part of this Resolution for all purposes.

**Section 2.** That the Public Service Board hereby requests the El Paso City Council to authorize the issuance of up to \$25,330,000 of City of El Paso, Texas, Municipal Drainage Utility System Revenue Refunding Bonds to pay off \$25,000,000 in Notes, and to fund interest and related transaction costs, provided that certain parameters approved by the Board are met.

**PASSED AND APPROVED** at the regular meeting of the Public Service Board, this 13th day of July, 2022, at which meeting a quorum was present and which was held in accordance with the provisions of Texas Government Code, Sections 551.001, et. seq.

ATTEST:

  
\_\_\_\_\_  
Bryan Morris, Secretary/Treasurer

EL PASO WATER UTILITIES  
PUBLIC SERVICE BOARD

  
\_\_\_\_\_  
Kristina D. Mena, Chair

APPROVED AS TO CONTENT:

  
\_\_\_\_\_  
Arturo Duran  
Chief Financial Officer

APPROVED AS TO FORM:

  
\_\_\_\_\_  
Daniel Ortiz  
General Counsel



---

---

ORDINANCE NO. \_\_\_\_\_

AUTHORIZING THE ISSUANCE OF

CITY OF EL PASO, TEXAS,  
MUNICIPAL DRAINAGE UTILITY SYSTEM REVENUE REFUNDING BONDS,  
SERIES 2023

Adopted: \_\_\_\_\_, 2022

## TABLE OF CONTENTS

		<u>Page</u>
ARTICLE 1	DEFINITIONS, FINDINGS AND INTERPRETATION .....	2
Section 1.01	Definitions.....	2
Section 1.02	Findings.....	8
Section 1.03	Table of Contents, Titles and Headings .....	8
Section 1.04	Interpretation.....	8
ARTICLE 2	SECURITY FOR THE BONDS .....	9
Section 2.01	Security for the Bonds .....	9
Section 2.02	Limited Obligations .....	9
Section 2.03	Security Interest .....	9
ARTICLE 3	AUTHORIZATION; GENERAL TERMS AND PROVISIONS REGARDING THE BONDS.....	9
Section 3.01	Authorization .....	9
Section 3.02	Delegation of Authority to Pricing Officer.....	9
Section 3.03	Date, Denomination, Maturities, Numbers and Interest. ....	10
Section 3.04	Medium, Method and Place of Payment.....	11
Section 3.05	Execution and Initial Registration .....	12
Section 3.06	Ownership.....	12
Section 3.07	Registration, Transfer and Exchange.....	13
Section 3.08	Cancellation and Authentication.....	14
Section 3.09	Temporary Bonds.....	15
Section 3.10	Replacement Bonds. ....	15
Section 3.11	Book-Entry Only System.....	16
Section 3.12	Successor Securities Depository; Transfer Outside Book-Entry Only System.....	17
Section 3.13	Payments to Cede & Co.....	17
ARTICLE 4	REDEMPTION OF BONDS BEFORE MATURITY .....	17
Section 4.01	Limitation on Redemption .....	17
ARTICLE 5	PAYING AGENT/REGISTRAR.....	17
Section 5.01	Appointment of Initial Paying Agent/Registrar.....	17
Section 5.02	Qualifications of Paying Agent/Registrar.....	18
Section 5.03	Maintaining Paying Agent/Registrar. ....	18
Section 5.04	Termination of Paying Agent/Registrar.....	18
Section 5.05	Notice of Change of Paying Agent/Registrar to Owners.....	18

TABLE OF CONTENTS  
(continued)

	<u>Page</u>
Section 5.06      Agreement of Paying Agent/Registrar to Perform Duties and Functions.....	18
Section 5.07      Delivery of Records to Successor .....	18
ARTICLE 6      FORM OF THE BONDS .....	18
Section 6.01      Form Generally .....	18
Section 6.02      Form of the Bonds .....	19
Section 6.03      CUSIP Registration.....	19
Section 6.04      Legal Opinion .....	19
Section 6.05      Statement of Insurance.....	19
ARTICLE 7      PUBLIC SERVICE BOARD.....	19
Section 7.01      Public Service Board.....	19
ARTICLE 8      FUNDS; FLOW OF FUNDS.....	21
Section 8.01      Special Funds.....	21
Section 8.02      Revenue Fund .....	21
Section 8.03      Investment of Funds.....	23
Section 8.04      Contributions in Aid of Construction .....	23
ARTICLE 9      DEPOSIT OF PROCEEDS; CONTROL AND DELIVERY OF BONDS .....	23
Section 9.01      Deposit of Proceeds. ....	23
Section 9.02      Control and Delivery of Bonds.....	24
ARTICLE 10     PARTICULAR REPRESENTATIONS AND COVENANTS .....	24
Section 10.01     Insurance .....	24
Section 10.02     Books and Records .....	24
Section 10.03     Additional Covenants.....	24
Section 10.04     Payment of Bonds.....	26
ARTICLE 11     COVENANTS TO MAINTAIN TAX EXEMPT STATUS .....	27
Section 11.01     Covenants to Maintain Tax Exempt Status.....	27
Section 11.02     Continuing Obligation .....	30
ARTICLE 12     DEFAULT AND REMEDIES.....	30
Section 12.01     Remedies in Event of Default .....	30
Section 12.02     Remedies Not Exclusive .....	31
ARTICLE 13     DISCHARGE.....	31

TABLE OF CONTENTS  
(continued)

		<u>Page</u>
	Section 13.01 Discharge .....	31
ARTICLE 14	SALE AND DELIVERY OF BONDS; OFFICIAL STATEMENT .....	32
Section 14.01	Sale of Bonds - Official Statement .....	32
ARTICLE 15	CONTINUING DISCLOSURE UNDERTAKING.....	33
Section 15.01	Annual Reports. ....	33
Section 15.02	Notice of Certain Events.....	33
Section 15.03	Filings with the MSRB .....	35
Section 15.04	Limitations, Disclaimers and Amendments.....	35
ARTICLE 16	PAYMENT OF REFUNDED REVOLVING NOTES; ESCROW AGENT.....	36
Section 16.01	Payment of Refunded Revolving Notes.....	36
Section 16.02	Escrow Agreement.....	36
ARTICLE 17	MISCELLANEOUS .....	38
Section 17.01	Amendment to Ordinance.....	38
Section 17.02	Further Procedures .....	39
Section 17.03	Municipal Bond Insurance.....	40
Section 17.04	Inconsistent Provisions .....	40
Section 17.05	Governing Law .....	40
Section 17.06	Effectiveness .....	40
EXHIBIT A PAYING AGENT/REGISTRAR AGREEMENT		
EXHIBIT B FORM OF BOND		

AN ORDINANCE AUTHORIZING THE ISSUANCE OF “CITY OF EL PASO, TEXAS, MUNICIPAL DRAINAGE UTILITY SYSTEM REVENUE REFUNDING BONDS, SERIES 2023” IN AN AMOUNT NOT TO EXCEED \$25,330,000 TO REFUND CERTAIN PREVIOUSLY ISSUED OBLIGATIONS OF THE CITY; AND RESOLVING MATTERS WHICH ARE NECESSARY TO EFFECT SUCH ISSUANCE, INCLUDING THE DELEGATION OF MATTERS RELATING TO THE SALE AND ISSUANCE OF THE BONDS TO AN AUTHORIZED CITY OFFICER OR EMPLOYEE WITHIN CERTAIN SPECIFIED PARAMETERS

WHEREAS, in accordance with the Constitution and the laws of the State of Texas, specifically Chapter 552 of the Texas Local Government Code, as amended, formerly known as Subchapter C of Chapter 402 of the Texas Local Government Code (the “Act”), the City of El Paso, Texas (the “City”) held public hearings on the creation of a municipal drainage utility system and adopted Ordinance No. 016668 on June 19, 2007, establishing and declaring the creation of the City’s Municipal Drainage Utility System (the “System”) within the municipal boundaries and unincorporated extraterritorial jurisdiction of the City; and

WHEREAS, in accordance with the Constitution and the laws of the State of Texas, specifically Texas Government Code, Chapter 1502, as amended, the City has previously issued municipal drainage utility system revenue bonds (the “Previously Issued Bonds”) payable from and secured by a first and superior lien on and pledge of the net revenues of the System; and

WHEREAS, there has been filed with the City Council one or more resolutions adopted and approved by the Public Service Board requesting the City Council to approve the issuance and sale of the City’s revenue bonds for the purpose of refunding certain obligations secured by revenues of the System; and

WHEREAS, the City Council hereby finds and determines that it is in the best interest of the City and the System to refund certain System revenue revolving notes (the “Refunded Revolving Notes”); and

WHEREAS, the City by this Ordinance and in accordance with the provisions of Texas Government Code, Chapter 1207, as amended (“Chapter 1207”) and Texas Government Code, Chapter 1371, as amended (“Chapter 1371”), is delegating to the Pricing Officer (hereinafter defined) the authority to establish the terms and details related to the issuance and sale of the bonds authorized by this Ordinance (the “Bonds”) including: (i) the principal amount of the Refunded Revolving Notes to be refunded, (ii) the form and designation of one or more series of Bonds; (iii) the principal amount of each series of the Bonds and the amount of the Bonds of each series to mature in each year; (iv) the dates, price, interest rates, interest payment dates, principal payment dates, and redemption features of each series of the Bonds; and (v) any other details relating to the issuance, sale, delivery, and/or exchange of the Bonds, all within certain specified parameters set forth herein; and

WHEREAS, the City Council hereby finds and determines that the refunding of the Refunded Revolving Notes for the purposes of making such debt long-term fixed rate debt of the City and restructuring the debt payable from the revenues of the System is in the best interest of the City, and the manner in which such refunding is being executed does not make it practicable

to make the determinations otherwise required by Texas Government Code, Section 1207.008(a)(2), as amended; and

WHEREAS, in the ordinances authorizing the Previously Issued Bonds, the City reserved the right and option to issue, under certain conditions, “Additional Bonds” on a parity as to lien and right with such bonds; and

WHEREAS, a public hearing was held, following proper publication of notice thereof, before the City Council with respect to the adoption of this Ordinance; and

WHEREAS, the City Council has found and determined that the bonds herein authorized should be issued on a parity with its Previously Issued Bonds, for the purposes aforesaid, pursuant to this Ordinance and as permitted by the General Laws of the State of Texas, particularly Chapter 1207 and Chapter 1371; and

WHEREAS, the meeting at which this Ordinance is considered is open to the public as required by law, and the public notice of the time, place and purpose of such meeting was given as required by Texas Government Code, Chapter 551, as amended;

NOW, THEREFORE, BE IT ORDAINED BY THE CITY COUNCIL OF THE CITY OF EL PASO, TEXAS, THAT:

## ARTICLE 1

### DEFINITIONS, FINDINGS AND INTERPRETATION

Section 1.01 Definitions. Unless otherwise expressly provided or unless the context clearly requires otherwise, in this Ordinance, the following terms shall have the meanings specified below:

“Act” means Chapter 552 of the Texas Local Government Code, as amended.

“Additional Bonds” means the additional revenue bonds permitted to be issued on a parity with the Bonds and the Previously Issued Bonds by Section 10.03(a) of this Ordinance.

“Average Annual Debt Service” means an amount which, at the time of computation, is derived by dividing the total amount of Debt Service to be paid over a period of years as the same is scheduled to become due and payable by the number of years taken into account in determining the total Debt Service. Capitalized interest payments provided from bond proceeds shall be excluded in making the aforementioned computation.

“Board” or “Board of Trustees” means that certain board of trustees known as the “Public Service Board” heretofore established for the purpose of managing the System and other water utilities of the City, as represented by the various persons appointed from time to time, and any successors thereto.

“Bond” means any of the Bonds.

“Bonds” means the City of El Paso, Texas, Municipal Drainage Utility System Revenue Refunding Bonds, Series 2023, authorized by Section 3.01 of this Ordinance, and any additional or different series or designation specified in an applicable Pricing Certificate.

“Bonds Similarly Secured” means collectively, the Previously Issued Bonds, the Bonds and Additional Bonds.

“Bond Counsel” means a firm of nationally recognized attorneys experienced in the issuance of bonds and acceptable to the City, initially Norton Rose Fulbright US LLP.

“Bullet Obligation” means all Bonds Similarly Secured of a series maturing in any single year in a principal amount that totals at least 15% of the initial aggregate principal amount of the entire series of such Bonds Similarly Secured.

“Business Day” means any day other than a Saturday, Sunday or legal holiday or other day on which banking institutions in the city where the Designated Payment/Transfer Office of the Paying Agent/Registrar is located in the State of Texas are generally authorized or obligated by law or executive order to close.

“Chapter 1207” means Texas Government Code, Chapter 1207, as amended.

“Chapter 1371” means Texas Government Code, Chapter 1371, as amended.

“Chapter 1502” means Texas Government Code, Chapter 1502, as amended.

“City” means the City of El Paso, Texas, and with respect to those matters requiring action regarding the authority and control of management and operation of the System or the expenditure and application of the System’s revenues, “City” shall mean the Board acting on behalf of the City.

“City Council” means the governing body of the City of El Paso, Texas.

“Closing Date” means the date of the initial delivery of and payment for each series of Bonds.

“Code” means the Internal Revenue Code of 1986, as amended, including the regulations and published rulings thereunder.

“Debt Service” means as of any particular date of computation, with respect to any obligations and with respect to any period, the aggregate of the amounts to be paid or set aside by the City as of such date or in such period for the payment of the principal of premium if any, and interest (to the extent not capitalized) on such obligations; provided, however, that in making such calculation the following rules shall apply:

(1) For any series of Bonds Similarly Secured issued at a variable rate, that such obligations bear, or would have borne, interest at the highest rate of (i) the actual rate on the date of calculation, or if the indebtedness is not yet outstanding, the initial rate (if established and binding), (ii) if the indebtedness has been outstanding for at least twelve months, the average rate over the twelve months

immediately preceding the date of calculation and (iii) (A) if interest on the indebtedness is excludable from gross income under the applicable provisions of the Internal Revenue Code, the most recently published Bond Buyer “Revenue Bond Index” (or comparable index if no longer published) plus 50 basis points, or (B) if interest is not so excludable, the interest rate on direct United States Treasury Obligations with comparable maturities plus 50 basis points; provided, however, that for purposes of any rate covenant measuring actual debt service during a test period, variable rate indebtedness shall be deemed to bear interest at the actual rate per annum applicable during the test period; and

(2) For any series of Bonds Similarly Secured issued as Short Term Obligations, Demand Obligations, or Bullet Obligations, Debt Service may be computed on the assumption that the principal amount shall be refinanced at maturity (or an earlier date on which principal thereof is payable on demand) by fixed rate Bonds Similarly Secured bearing interest at (a) if the interest on such obligations is excludable from gross income of the owners thereof for federal income tax purposes, a Revenue Bond Index published by the Bond Buyer or any successor publication or (b) if the interest on such obligations is not excludable from gross income of the owners thereof for federal income tax purposes, the yield on the Treasury Constant Maturity Series as reported in Federal Reserve Statistical Release H.15, Selected Interest Rates of the Board of Governors of the Federal Reserve System, or any successor publication as certified by the City’s financial advisor, in both cases (a) and (b) within 30 days prior to the date of such calculation (or the gross fixed or capped rate payable by the City under an interest rate swap or cap agreement that substantially hedges the rate of interest on such Bonds Similarly Secured) and maturing in substantially equal annual payments of principal and interest over a term of 25 years (or such longer period as a nationally recognized financial advisor or investment banker certifies is then reasonably attainable) or less; and

(3) For any series of Bonds Similarly Secured for which the City is entitled to receive payments from the federal or state government in such period on account of, and substantially contemporaneously with, interest paid on such Bonds Similarly Secured, the amount to be received in such period shall be deducted from such interest in computing Debt Service.

“Demand Obligations” means any Bonds Similarly Secured the principal of which is payable by the City on demand of the owner or holder thereof.

“Depository Bank” means any financial institution duly designated by the Board to serve as a depository for funds controlled by the Board.

“Designated Payment/Transfer Office” means (i) with respect to the initial Paying Agent/Registrar named herein, its designated office specified in the Pricing Certificate, or at such other location designated by the Paying Agent/Registrar and (ii) with respect to any successor Paying Agent/Registrar, the office of such successor designated and located as may be agreed upon by the City and such successor.



“DTC” means The Depository Trust Company of New York, New York, or any successor securities depository.

“DTC Participant” means brokers and dealers, banks, trust companies, clearing corporations and certain other organizations on whose behalf DTC was created to hold securities to facilitate the clearance and settlement of securities transactions among DTC Participants.

“EPWU” means the El Paso Water Utilities, a component unit of the City of El Paso and any successors thereto.

“Escrow Agent” means the Escrow Agent, if any, appointed and approved in the Pricing Certificate.

“Escrow Agreement” means the Escrow Agreement, if any, by and between the City and the Escrow Agent appointed and approved in the Pricing Certificate.

“Financial Advisor” means a registered “municipal advisor” under Section 15B of the Securities Exchange Act of 1934, as amended, selected by the City to provide advice to the City in the area of municipal financial products or the issuance of municipal securities, initially Hilltop Securities Inc.

“Financial Obligation” means a (a) debt obligation; (b) derivative instrument entered into in connection with, or pledged as security or a source of payment for, an existing or planned debt obligation; or (c) guarantee of a debt obligation or any such derivative instrument; provided that “financial obligation” shall not include municipal securities as to which a final official statement (as defined in the Rule) has been provided to the MSRB consistent with the Rule.

“Fiscal Year” means the twelve month financial accounting period used by the Board in connection with the operation of the System which may be any twelve consecutive month period established by the Board.

“Government Obligations” means, unless otherwise provided in the Pricing Certificate, (i) direct noncallable obligations of the United States of America, including obligations the principal of and interest on which are unconditionally guaranteed by the United States of America, (ii) noncallable obligations of an agency or instrumentality of the United States, including obligations unconditionally guaranteed or insured by the agency or instrumentality and, on the date of their acquisition or purchase by the City, are rated as to investment quality by a nationally recognized investment rating firm not less than AAA or its equivalent, (iii) noncallable obligations of a state or an agency or a county, municipality, or other political subdivision of a state that have been refunded and that, on the date of their acquisition or purchase by the City, are rated as to investment quality by a nationally recognized investment rating firm not less than AAA or its equivalent and (iv) any other then authorized securities or obligations that may be used to defease obligations such as the Bonds under the then applicable laws of the State of Texas.

“Improvement Fund” means the fund by such name described in Section 8.01(a)(iv) hereof.

“Initial Bond” means the Initial Bond authorized by Section 3.03 of this Ordinance.

“Initial Date” means the date designated as the Initial Date in the Pricing Certificate.

“Interest and Sinking Fund” means the fund by that name described in Section 8.01(a) hereof.

“Interest Payment Date” means the date or dates on which interest on the principal of the Bonds is scheduled to be paid until their respective dates of maturity or prior redemption, such dates being March 1 and September 1, commencing on the date specified in the Pricing Certificate.

“Issue Price” has the meaning stated in section 1.148-1(b) of the Regulations.

“MSRB” means the Municipal Securities Rulemaking Board.

“Net Revenues” shall mean Revenues of the System, with respect to any period, after deducting the System’s Operating and Maintenance Expenses during such period.

“Note Payment Fund” means the fund so designated in Section 8.01(b) hereof.

“Operating and Maintenance Expenses” shall mean all current expenses of operating and maintaining the System not paid from the proceeds of any Debt, including all salaries, labor, materials and administrative costs, allocable under generally accepted accounting principles, to the System. Depreciation charges and other costs and disbursements which may be capitalized under generally accepted accounting principles shall not be considered Operating and Maintenance Expenses.

“Outstanding” means when used in this Ordinance with respect to Bonds or Bonds Similarly Secured, as the case may be, means, as of the date of determination, all Bonds and Bonds Similarly Secured theretofore sold, issued and delivered by the City, except:

- (1) Bonds or Bonds Similarly Secured canceled or delivered to the transfer agent or registrar for cancellation in connection with the exchange or transfer of such obligations;
- (2) Bonds or Bonds Similarly Secured paid or deemed to be paid in accordance with applicable law; and
- (3) Bonds or Bonds Similarly Secured that have been mutilated, destroyed, lost, or stolen and replacement bonds have been registered and delivered in lieu thereof.

“Owner” means the person who is the registered owner of a Bond or Bonds.

“Paying Agent/Registrar” means Computershare Trust Company, N.A. (or such other entity or banking association determined by the Pricing Officer in the Pricing Certificate) or any successor thereto or replacement therefor as provided in this Ordinance.

“Pricing Certificate” means collectively one or more pricing certificates that set forth the terms of one or more series of Bonds in accordance with Section 3.02 of this Ordinance and

executed by the Pricing Officer, all in accordance with the provisions of Chapter 1207 and Chapter 1371.

“Pricing Officer” means the President/Chief Executive Officer of the EPWU, or in the absence thereof, the Vice President of Strategic, Financial and Management Services of the EPWU or the Chief Financial Officer of the EPWU, each acting in such capacity severally and not jointly.

“Previously Issued Bonds” means the outstanding bonds of the following issues: (1) City of El Paso, Texas, Municipal Drainage Utility System Revenue Bonds, Series 2009A, (2) City of El Paso, Texas, Municipal Drainage Utility System Revenue Bonds, Series 2015, (3) City of El Paso, Texas, Municipal Drainage Utility System Revenue Bonds, Series 2016, (4) City of El Paso, Texas, Municipal Drainage Utility System Revenue Improvement and Refunding Bonds, Series 2017, (5) City of El Paso, Texas, Municipal Drainage Utility System Revenue Refunding Bonds, Taxable Series 2021, (6) City of El Paso, Texas, Municipal Drainage Utility System Revenue Refunding Bonds, Series 2021A, (7) City of El Paso, Texas, Municipal Drainage Utility System Revenue Bonds, Series 2022, and (8) City of El Paso, Texas, Municipal Drainage Utility System Revenue Refunding Bonds, Series 2022A.

“Purchaser” means the initial purchaser of each series of Bonds issued hereunder as named in the applicable Pricing Certificate.

“Record Date” means with respect to each interest payment date the fifteenth day of the month next preceding such interest payment date.

“Refunded Revolving Notes” means the revolving notes described in the Pricing Certificate.

“Register” means the Register specified in Section 3.07 of this Ordinance.

“Reserve Fund” means the fund by that name described in Section 8.01(a)(iii) hereof.

“Reserve Fund Requirement” means the amount which is equal to the lesser of (i) the Average Annual Debt Service (calculated on a Fiscal Year basis) for all Bonds Similarly Secured then Outstanding, as determined on the date each series of Additional Bonds are delivered or incurred, as the case may be, or (ii) the maximum amount in a reasonably required reserve fund that can be invested without restriction as to yield pursuant to Subsection (d) of Section 148 of the Internal Revenue Code of 1986, as amended, and regulations promulgated thereunder.

“Revenue Fund” means the Drainage Utility System Revenue Fund established in Section 8.01(a)(i) hereof.

“Revenues” shall mean all income, receipts and revenues of every nature derived or received from the operation and ownership (excluding restricted gifts, grants in aid of construction and any amounts received from drainage charges specifically provided by ordinance for contribution to the funding of future drainage system construction) of the System, including earnings and income derived from the investment or deposit of moneys in any special funds or accounts created and established for the payment and security of the Bonds Similarly Secured and other obligations payable solely from and secured only by a lien on and pledge of the Net Revenues

of the System, and excluding those amounts subject to payment to the United States of America as rebate pursuant to section 148 of the Code and any federal subsidies received pursuant to section 6431 of the Code.

“Rule” means SEC Rule 15c2-12, as amended from time to time or officially interpreted by the SEC.

“SEC” means the United States Securities and Exchange Commission.

“Short Term Obligations” means each series of bonds, notes and other debt obligations issued pursuant to a commercial paper or other similar financing program, the payment of principal of which is scheduled to be payable within one year from the date of issuance and is contemplated at the time of issuance to be refinanced through the issuance of Additional Bonds.

“Subordinate Lien Obligations” shall mean the obligations of the City under the City’s Tax-Exempt Revolving Notes, Series A and Taxable Revolving Notes, Series B and the documents pertaining thereto.

“System” or “Municipal Drainage Utility System” shall mean all land, easements and interest in land, together with all structures, equipment and facilities used in draining benefitted property (within the meaning of the Act), including, but not limited to, catch basins, channels, conduits, creeks, culverts, detention ponds, ditches, draws, flumes, pipes, pumps, sloughs, treatment works, and appurtenances to those items, whether natural or artificial, or using force or gravity, that are used to draw off surface water from land, carry the water away, collect, store, or treat the water, or divert the water into natural or artificial watercourses (but excluding City parks, roads, streets and bridges in existence on June 19, 2007) and excluding the property or entities exempted from the Act pursuant to Section 552.053 of the Act.

Section 1.02 Findings. The declarations, determinations and findings declared, made and found in the preamble to this Ordinance are hereby adopted, restated and made a part of the operative provisions hereof.

Section 1.03 Table of Contents, Titles and Headings. The table of contents, titles and headings of the Articles and Sections of this Ordinance have been inserted for convenience of reference only and are not to be considered a part hereof and shall not in any way modify or restrict any of the terms or provisions hereof and shall never be considered or given any effect in construing this Ordinance or any provision hereof or in ascertaining intent, if any question of intent should arise.

Section 1.04 Interpretation.

Unless the context requires otherwise, words of the masculine gender shall be construed to include correlative words of the feminine and neuter genders and vice versa, and words of the singular number shall be construed to include correlative words of the plural number and vice versa.

This Ordinance and all the terms and provisions hereof shall be liberally construed to effectuate the purposes set forth herein to sustain the validity of this Ordinance.

## ARTICLE 2

### SECURITY FOR THE BONDS

Section 2.01 Security for the Bonds. The Bonds Similarly Secured, both principal and interest, are and shall be equally and ratably secured by and payable from an irrevocable first lien on and pledge of the Net Revenues.

Section 2.02 Limited Obligations. The Bonds Similarly Secured are special obligations of the City, payable solely from the Net Revenues, and do not constitute a prohibited indebtedness of the City. The Bonds Similarly Secured shall never be payable out of funds raised or to be raised by taxation.

Section 2.03 Security Interest. The City represents that, under Chapter 1208.002, Texas Government Code, a security interest in property, other than real property, that is created by the City is valid and effective according to the terms of the security agreement and is perfected from the time the security agreement is entered into or adopted continuously through the termination of the security interest, without physical delivery or transfer of control of the property, filing of a document, or another act. The City covenants that, if Chapter 1208.002 is amended at any time while the Bonds Similarly Secured are Outstanding, the City shall take all actions required in order to preserve for the Owners of the Previously Issued Bonds, the Bonds or Additional Bonds a perfected security interest in the property in which such security interest is granted pursuant to Section 2.01 hereof.

## ARTICLE 3

### AUTHORIZATION; GENERAL TERMS AND PROVISIONS REGARDING THE BONDS

Section 3.01 Authorization. Revenue bonds of the City are hereby authorized to be issued, in one or more series, in the maximum aggregate principal amount set forth in Section 3.02 hereof. Unless otherwise specified in a Pricing Certificate, such revenue bonds shall be designated and bear the title the “City of El Paso, Texas, Municipal Drainage Utility System Revenue Refunding Bonds, Series 2023” and/or such additional or different series or designations as specified by the Pricing Officer in an applicable Pricing Certificate. The Bonds shall be issued for the purposes of (i) refunding the Refunded Revolving Notes and (ii) paying the costs of issuing the Bonds, all as provided in each Pricing Certificate and in accordance with the Constitution and laws of the State of Texas, particularly Chapter 1207, Chapter 1371, and the Charter of the City.

Section 3.02 Delegation of Authority to Pricing Officer.

(a) As authorized by Chapter 1207 and Chapter 1371, the Pricing Officer is hereby authorized to act on behalf of the City in selling and delivering the Bonds, in one or more series, and carrying out the other procedures specified in this Ordinance, including selection of the specific maturities or series (whole or part) of the Refunded Revolving Notes to be refunded, determining the aggregate original principal amount of each series of Bonds, the Initial Date of each series of Bonds, any additional or different designation or title by which the Bonds shall be

known, the manner of sale (negotiated, privately placed or competitively bid), the price at which the Bonds of each series will be sold, the years in which the Bonds of each series will mature, the terms of any bond insurance applicable to a series of Bonds, the principal amount to mature in each of such years, the rate of interest to be borne by each such maturity, the interest payment dates, the price and terms upon and at which the Bonds of each series shall be subject to redemption prior to maturity at the option of the City, as well as any mandatory sinking fund redemption provisions, the designation of a paying agent/registrar, the designation of an escrow agent, if necessary, and all other matters relating to the issuance, sale, and delivery of the Bonds all of which shall be specified in the Pricing Certificate; provided that:

(i) the aggregate original principal amount of all series of Bonds issued hereunder shall not exceed \$25,330,000;

(ii) the aggregate true interest cost percentage for each series of Bonds issued hereunder shall not exceed 6.50%; and

(iii) the maximum maturity date for each series of Bonds issued hereunder shall not exceed December 31, 2043.

(b) In establishing the aggregate principal amount of the Bonds, the Pricing Officer shall establish an amount not exceeding the amount authorized in Subsection (a)(i) above, which shall be sufficient in amount to provide for the purpose for which the Bonds are authorized and to pay costs of issuing the Bonds. Unless otherwise extended by an act of City Council, the delegation made hereby shall expire if not exercised by the Pricing Officer within 270 days from the date hereof. The Pricing Officer may exercise such delegation on more than one occasion during such time period.

(c) The execution of the Pricing Certificate shall evidence the sale date of the applicable series of Bonds by the City to the Purchaser.

(d) If the Pricing Officer determines that insurance results in a net reduction of the City's interest costs associated with the Bonds, then the Pricing Officer is authorized, in connection with effecting the sale of the Bonds, to obtain from a municipal bond insurance company (the "Insurer") a municipal bond insurance policy in support of the Bonds. To that end, should the Pricing Officer exercise such authority and commit the City to obtain a municipal bond insurance policy, for so long as such policy is in effect, the requirements of the Insurer relating to the issuance of such policies are incorporated by reference into this Ordinance and made a part hereof for all purposes, notwithstanding any other provision of this Ordinance to the contrary. Each of the City Manager of the City, the President/Chief Executive Officer of the EPWU and the Pricing Officer shall have the authority to execute any documents to effect the issuance of such policy by the Insurer.

### Section 3.03 Date, Denomination, Maturities, Numbers and Interest.

(a) The Bonds shall have the Initial Date specified in the Pricing Certificate. The Bonds shall be in fully registered form, without coupons, and shall be numbered consecutively from one upward, except the Initial Bond, which shall be numbered as specified in Section 6.02.

(b) The Bonds shall be in the denomination of \$5,000 or any integral multiple thereof, shall mature on March 1 or September 1 in the years and in the principal amounts and shall bear interest at the per annum rates as specified in the Pricing Certificate.

(c) Interest shall accrue and be paid on each Bond respectively until its maturity or earlier redemption from the date specified in the Pricing Certificate or the most recent interest payment date to which interest has been paid or provided for at the per annum rates specified in the schedule contained in the Pricing Certificate. Such interest shall be payable semiannually on March 1 and September 1 of each year, commencing on the date specified in the Pricing Certificate, computed on the basis of a 360-day year of twelve 30-day months.

Section 3.04 Medium, Method and Place of Payment.

(a) The principal of and interest on the Bonds shall be paid in lawful money of the United States of America, as provided in this Section.

(b) Interest on the Bonds shall be paid to the Owners thereof as shown in the Register at the close of business on the Record Date by check (dated as of the Interest Payment Date) and sent by the Paying Agent/Registrar to the person entitled to such payment by United States mail, first-class, postage prepaid, to the address of such person as it appears in the Register, or by such other customary banking arrangements acceptable to the Paying Agent/Registrar and the person to whom interest is paid; provided, however, that such person shall bear all risk and expense of such other customary banking arrangements.

(c) The principal of each Bond shall be paid to the Owner of such Bond on the due date thereof (whether at the maturity date or the date of prior redemption thereof) upon presentation and surrender of such Bond at the Designated Payment/Transfer Office of the Paying Agent/Registrar.

(d) If the date for the payment of the principal of or interest on the Bonds is not a Business Day, the date for such payment shall be the next succeeding Business Day, and payment on such date shall for all purposes be deemed to have been made on the due date thereof as specified in this Section.

(e) In the event of a nonpayment of interest on a Bond on a scheduled payment date, and for thirty (30) days thereafter, a new record date for such interest payment (a "Special Record Date") will be established by the Paying Agent/Registrar, if and when funds for the payment of such interest have been received from the City. Notice of the Special Record Date and of the scheduled payment date of the past due interest (which shall be fifteen (15) days after the Special Record Date) shall be sent at least five business days prior to the Special Record Date by United States mail, first-class, postage prepaid, to the address of each Owner of a Bond appearing on the books of the Paying Agent/Registrar at the close of business on the last business day next preceding the date of mailing of such notice.

(f) Unclaimed payments shall be segregated in a special escrow account and held in trust, uninvested by the Paying Agent/Registrar, for the account of the Owner of the Bonds to which the unclaimed payments pertain. Subject to Title 6 of the Texas Property Code, payments remaining unclaimed by the Owners entitled thereto for three years after the applicable payment

or redemption date shall be applied to the next payment or payments on the Bonds thereafter coming due and, to the extent any such money remains after the retirement of all outstanding Bonds, shall be paid to the City to be used for any lawful purpose. Thereafter, neither the City, the Paying Agent/Registrar nor any other person shall be liable or responsible to any Owners of such Bonds for any further payment of such unclaimed moneys or on account of any such Bonds, subject to Title 6 of the Texas Property Code.

Section 3.05 Execution and Initial Registration. The Bonds shall be executed on behalf of the City by the Mayor or Mayor Pro Tem and the City Clerk or Alternate City Clerk as of the date of adoption of this Ordinance, by their manual or facsimile signatures, and the official seal of the City shall be impressed or placed in facsimile thereon. Such facsimile signatures on the Bonds shall have the same effect as if each of the Bonds had been signed manually and in person by each of such officers, and such facsimile seal on the Bonds shall have the same effect as if the official seal of the City had been manually impressed upon each of the Bonds.

(a) In the event any officer of the City whose manual or facsimile signature appears on the Bonds ceases to be such officer before the authentication of such Bonds or before the delivery thereof, such facsimile signature nevertheless shall be valid and sufficient for all purposes as if such officer had remained in such office.

(b) Except as provided below, no Bond shall be valid or obligatory for any purpose or be entitled to any security or benefit of this Ordinance unless and until there appears thereon the Certificate of Paying Agent/Registrar substantially in the form provided herein, duly authenticated by manual execution by an officer or duly authorized signatory of the Paying Agent/Registrar. It shall not be required that the same officer or authorized signatory of the Paying Agent/Registrar sign the Certificate of Paying Agent/Registrar on all of the Bonds. In lieu of the executed Certificate of Paying Agent/Registrar described above, the Initial Bond delivered on the Closing Date shall have attached thereto the Comptroller's Registration Certificate substantially in the form provided herein, manually executed by the Comptroller of Public Accounts of the State of Texas, or by his duly authorized agent, which certificate shall be evidence that the Initial Bond of each series has been duly approved by the Attorney General of the State of Texas and that they are valid and binding special obligations of the City, and have been registered by the Comptroller of Public Accounts of the State of Texas.

(c) On the Closing Date, one Initial Bond for each series of Bonds, payable in stated installments to the Purchaser or its designee, executed by manual or facsimile signature of the Mayor or Mayor Pro Tem and City Clerk or Alternate City Clerk, approved by the Attorney General, and registered and manually signed by the Comptroller of Public Accounts will be delivered to the Purchaser or its designee. Upon payment for each Initial Bond, the Paying Agent/Registrar shall cancel such Initial Bond and deliver registered definitive Bonds to DTC in accordance with Sections 3.09 and 3.11.

Section 3.06 Ownership.

(a) The City, the Paying Agent/Registrar and any other person may treat the person in whose name any Bond is registered as the absolute owner of such Bond for the purpose of making and receiving payment of the principal, for the further purpose of making and receiving payment



of the interest thereon (subject to the terms of this Ordinance requiring the Paying Agent/Registrar to make payments of interest to the person who is the registered owner on the Record Date or the Special Record Date), and for all other purposes, whether or not such Bond is overdue, and neither the City nor the Paying Agent/Registrar shall be bound by any notice or knowledge to the contrary.

(b) All payments made to the person deemed to be the Owner of any Bond in accordance with this Section shall be valid and effectual and shall discharge the liability of the City and the Paying Agent/Registrar upon such Bond to the extent of the sums paid.

Section 3.07 Registration, Transfer and Exchange.

(a) So long as any Bonds remain outstanding, the City shall cause the Paying Agent/Registrar to keep at the Designated Payment/Transfer Office a register (the "Register") in which, subject to such reasonable regulations as it may prescribe, the Paying Agent/Registrar shall provide for the registration and transfer of Bonds in accordance with this Ordinance.

(b) Registration of any Bond may be transferred in the Register only upon the presentation and surrender thereof at the Designated Payment/Transfer Office of the Paying Agent/Registrar for transfer of registration and cancellation, together with proper written instruments of assignment, in form and with guarantee of signatures satisfactory to the Paying Agent/Registrar, evidencing assignment of the Bonds, or any portion thereof in any integral multiple of \$5,000, to the assignee or assignees thereof, and the right of such assignee or assignees thereof to have the Bond or any portion thereof registered in the name of such assignee or assignees. No transfer of any Bond shall be effective until entered in the Register. Upon assignment and transfer of any Bond or portion thereof, a new Bond or Bonds will be issued by the Paying Agent/Registrar in exchange for such transferred and assigned Bond. To the extent possible the Paying Agent/Registrar will issue such new Bond or Bonds in not more than three business days after receipt of the Bond to be transferred in proper form and with proper instructions directing such transfer.

(c) Any Bond may be exchanged only upon the presentation and surrender thereof at the Designated Payment/Transfer Office of the Paying Agent/Registrar, together with a written request therefor duly executed by the registered owner or assignee or assignees thereof, or its or their duly authorized attorneys or representatives, with guarantees of signatures satisfactory to the Paying Agent/Registrar, for a Bond or Bonds of like series, of the same maturity and interest rate and in any authorized denomination and in an aggregate principal amount equal to the unpaid principal amount of the Bond presented for exchange. If a portion of any Bond is redeemed prior to its scheduled maturity as provided herein, a substitute Bond or Bonds of like series, having the same maturity date, bearing interest at the same rate, in the denomination or denominations of any integral multiple of \$5,000 at the request of the registered owner, and in an aggregate principal amount equal to the unredeemed portion thereof, will be issued to the registered owner upon surrender thereof for cancellation. To the extent possible, a new Bond or Bonds will be required to be delivered by the Paying Agent/Registrar to the registered owner of the Bond or Bonds in not more than three business days after receipt of the Bond to be exchanged in proper form and with proper instructions directing such exchange.

(d) Each Bond issued in exchange for any Bond or portion thereof assigned or transferred shall be of like series, of the same tenor and shall have the same maturity date and bear interest at the same rate and in the same manner as the Bond for which it is being exchanged. Each substitute Bond shall bear a letter and/or number to distinguish it from each other Bond. The Paying Agent/Registrar shall exchange the Bonds as provided herein, and each substitute Bond delivered in accordance with this Section shall constitute an original additional contractual obligation of the City and shall be entitled to the benefits and security of this Ordinance to the same extent as the Bond or Bonds in lieu of which such substitute Bond is delivered.

(e) The City will pay the Paying Agent/Registrar's reasonable and customary charge for the initial registration of the Bonds and the subsequent exchange of the Bonds pursuant to the provisions hereof. However, the Paying Agent/Registrar will require the Owner to pay a sum sufficient to cover any tax or other governmental charge that is authorized to be imposed in connection with the registration, transfer or exchange of a Bond. In addition, the City hereby covenants with the Owners of the Bonds that it will (i) pay the reasonable and standard or customary fees and charges of the Paying Agent/Registrar for its services with respect to the payment of the principal of and interest on the Bonds, when due, and (ii) pay the fees and charges of the Paying Agent/Registrar for services with respect to the transfer, registration and exchange of Bonds as provided herein to the extent such fees and charges are payable hereunder by the City.

(f) Neither the City nor the Paying Agent/Registrar shall be required to issue, transfer or exchange any Bond called for redemption, in whole or in part, where such redemption is scheduled to occur within 45 calendar days of the transfer or exchange date; provided, however, such limitation shall not be applicable to an exchange by the owner of the uncalled principal balance of a Bond.

### Section 3.08 Cancellation and Authentication.

(a) All Bonds paid or redeemed before scheduled maturity in accordance with this Ordinance, and all Bonds in lieu of which exchange Bonds or replacement Bonds are authenticated and delivered in accordance with this Ordinance, shall be canceled upon the making of proper records regarding such payment, redemption, exchange or replacement.

(b) Each substitute Bond issued in exchange for or replacement of (pursuant to the provisions of Section 3.10 hereof) any Bond or Bonds issued under this Ordinance shall have printed thereon a Paying Agent/Registrar's Authentication Certificate, in the form hereinafter set forth. An authorized representative of the Paying Agent/Registrar shall, before the delivery of any such bond, manually sign and date such Certificate, and no such Bond shall be deemed to be issued or outstanding unless such Certificate is so executed. No additional ordinances, orders, or resolutions need be passed or adopted by the City Council or any other body or person so as to accomplish the foregoing exchange or replacement of any Bond or portion thereof, and the Paying Agent/Registrar shall provide for the printing, execution, and delivery of the substitute Bonds in the manner prescribed herein. Pursuant to Texas Government Code, Chapter 1201, as amended, the duty of exchange or replacement of Bonds as aforesaid is hereby imposed upon the Paying Agent/Registrar, and, upon the execution of the above Paying Agent/Registrar's Authentication Certificate, the exchanged or replaced Bonds shall be valid, incontestable, and enforceable in the same manner and with the same effect as the Bonds which originally were delivered pursuant to

this Ordinance, approved by the Attorney General, and registered by the Comptroller of Public Accounts.

Section 3.09 Temporary Bonds.

(a) Pending the preparation of definitive Bonds, the City may execute and, upon the City's request, the Paying Agent/Registrar shall authenticate and deliver, one or more temporary Bonds that are printed, lithographed, typewritten, mimeographed or otherwise produced, in any denomination, substantially of the tenor of the definitive Bonds in lieu of which they are delivered, without coupons, and with such appropriate insertions, omissions, substitutions and other variations as the officers of the City executing such temporary Bonds may determine, as evidenced by their signing of such temporary Bonds.

(b) Until exchanged for Bonds in definitive form, such Bonds in temporary form shall be entitled to the benefit and security of this Ordinance. The City, without unreasonable delay, shall prepare, execute and deliver to the Paying Agent/Registrar, and thereupon, upon the presentation and surrender of the Bond or Bonds in temporary form to the Paying Agent/Registrar, the Paying Agent/Registrar shall authenticate and deliver in exchange therefor a Bond or Bonds of the same maturity and series, in definitive form, in the authorized denomination, and in the same aggregate principal amount as the Bond or Bonds in temporary form surrendered. Such exchange shall be made without the making of any charge therefor to any Owner.

Section 3.10 Replacement Bonds.

(a) Upon the presentation and surrender to the Paying Agent/Registrar of a mutilated Bond, the Paying Agent/Registrar shall authenticate and deliver in exchange therefor a replacement Bond of like series, of like tenor and principal amount, bearing a number not contemporaneously outstanding. The City or the Paying Agent/Registrar may require the Owner of such Bond to pay a sum sufficient to cover any tax or other governmental charge that is authorized to be imposed in connection therewith and any other expenses connected therewith.

(b) In the event that any Bond is lost, apparently destroyed or wrongfully taken, the Paying Agent/Registrar, pursuant to the applicable laws of the State of Texas and in the absence of notice or knowledge that such Bond has been acquired by a bona fide purchaser, shall authenticate and deliver a replacement Bond of like tenor and principal amount, bearing a number not contemporaneously outstanding, provided that the Owner first:

(i) furnishes to the Paying Agent/Registrar satisfactory evidence of his or her ownership of and the circumstances of the loss, destruction or theft of such Bond;

(ii) furnishes such security or indemnity as may be required by the Paying Agent/Registrar and the City, to save each of them harmless;

(iii) pays all expenses and charges in connection therewith, including, but not limited to, printing costs, legal fees, fees of the Paying Agent/Registrar and any tax or other governmental charge that is authorized to be imposed; and

(iv) satisfies any other reasonable requirements imposed by the City and the Paying Agent/Registrar.

(c) If, after the delivery of such replacement Bond, a bona fide purchaser of the original Bond in lieu of which such replacement Bond was issued presents for payment such original Bond, the City and the Paying Agent/Registrar shall be entitled to recover such replacement Bond from the person to whom it was delivered or any person taking therefrom, except a bona fide purchaser, and shall be entitled to recover upon the security or indemnity provided therefor to the extent of any loss, damage, cost or expense incurred by the City or the Paying Agent/Registrar in connection therewith.

(d) In the event that any such mutilated, lost, apparently destroyed or wrongfully taken Bond has become or is about to become due and payable, the Paying Agent/Registrar, in its discretion, without the necessity of issuing a replacement Bond, may pay such Bond on the date on which such Bond becomes due and payable.

(e) Each replacement Bond delivered in accordance with this Section shall constitute an original additional contractual obligation of the City and shall be entitled to the benefits and security of this Ordinance to the same extent as the Bond or Bonds in lieu of which such replacement Bond is delivered.

#### Section 3.11 Book-Entry Only System.

(a) Notwithstanding any other provision hereof, upon initial issuance of the Bonds, the ownership of the Bonds shall be registered in the name of Cede & Co., as nominee of DTC. The definitive Bonds shall be initially issued in the form of a single separate fully registered certificate for each of the maturities thereof.

(b) With respect to Bonds registered in the name of Cede & Co., as nominee of DTC, the City and the Paying Agent/Registrar shall have no responsibility or obligation to any DTC Participant or to any person on behalf of whom such a DTC Participant holds an interest in the Bonds. Without limiting the immediately preceding sentence, the City and the Paying Agent/Registrar shall have no responsibility or obligation with respect to (i) the accuracy of the records of DTC, Cede & Co. or any DTC Participant with respect to any ownership interest in the Bonds, (ii) the delivery to any DTC Participant or any other person, other than an Owner, as shown on the Register, of any notice with respect to the Bonds, including any notice of redemption, or (iii) the payment to any DTC Participant or any other person, other than an Owner, as shown in the Register of any amount with respect to principal of, premium, if any, or interest on the Bonds. Notwithstanding any other provision of this Ordinance to the contrary, the City and the Paying Agent/Registrar shall be entitled to treat and consider the person in whose name each Bond is registered in the Register as the absolute owner of such Bond for the purpose of payment of principal of, premium, if any, and interest on, the Bonds, for the purpose of all matters with respect to such Bond, for the purpose of registering transfer with respect to such Bond, and for all other purposes whatsoever. The Paying Agent/Registrar shall pay all principal of, premium, if any, and interest on the Bonds only to or upon the order of the respective owners, as shown in the Register as provided in this Ordinance, or their respective attorneys duly authorized in writing, and all such payments shall be valid and effective to fully satisfy and discharge the City's obligations with respect to payment of, premium, if any, and interest on the Bonds to the extent of the sum or sums

so paid. No person other than an owner, as shown in the Register, shall receive a certificate evidencing the obligation of the City to make payments of amounts due pursuant to this Ordinance. Upon delivery by DTC to the Paying Agent/Registrar of written notice to the effect that DTC has determined to substitute a new nominee in place of Cede & Co., the word “Cede & Co.” in this Ordinance shall refer to such new nominee of DTC.

Section 3.12 Successor Securities Depository; Transfer Outside Book-Entry Only System. In the event that the City or the Paying Agent/Registrar determines that DTC is incapable of discharging its responsibilities described herein and in the representation letter of the City to DTC, or in the event DTC discontinues the services described herein, the City or the Paying Agent/Registrar shall (i) appoint a successor securities depository, qualified to act as such under Section 17(a) of the Securities Exchange Act of 1934, as amended, notify DTC and DTC Participants of the appointment of such successor securities depository and transfer one or more separate Bonds to such successor securities depository or (ii) notify DTC and DTC Participants of the availability through DTC of Bonds and transfer one or more separate Bonds to DTC Participants having Bonds credited to their DTC accounts. In such event, the Bonds shall no longer be restricted to being registered in the Register in the name of Cede & Co., as nominee of DTC, but may be registered in the name of the successor securities depository, or its nominee, or in whatever name or names Owners transferring or exchanging Bonds shall designate, in accordance with the provisions of this Ordinance.

Section 3.13 Payments to Cede & Co. Notwithstanding any other provision of this Ordinance to the contrary, so long as any Bonds are registered in the name of Cede & Co., as nominee of DTC, all payments with respect to principal of, premium, if any, and interest on the Bonds, and all notices with respect to such Bonds, shall be made and given, respectively, in the manner provided in the blanket representation letter of the City to DTC.

#### ARTICLE 4

##### REDEMPTION OF BONDS BEFORE MATURITY

Section 4.01 Limitation on Redemption. The Bonds of each series shall be subject to redemption before their scheduled maturity only as provided in the applicable Pricing Certificate.

#### ARTICLE 5

##### PAYING AGENT/REGISTRAR

Section 5.01 Appointment of Initial Paying Agent/Registrar.

(a) Unless otherwise specified in the Pricing Certificate, Computershare Trust Company, N.A., a national banking association organized under the laws of the United States of America authorized to do business in the State of Texas, is hereby appointed as the initial Paying Agent/Registrar for the Bonds.

(b) The Pricing Officer is authorized and directed to execute an agreement with the Paying Agent/Registrar specifying the duties and responsibilities of the City and the Paying Agent/Registrar substantially in the form attached hereto as **Exhibit A**.

Section 5.02 Qualifications of Paying Agent/Registrar. Each Paying Agent/Registrar shall be a commercial bank, a national banking association trust company organized under the laws of the State of Texas, or other entity duly qualified and legally authorized to serve as, and perform the duties and services of, paying agent and registrar for the Bonds.

Section 5.03 Maintaining Paying Agent/Registrar.

(a) At all times while any Bonds are outstanding, the City will maintain a Paying Agent/Registrar that is qualified under Section 5.02 of this Ordinance.

(b) If the Paying Agent/Registrar resigns or otherwise ceases to serve as such, the City will promptly appoint a replacement.

Section 5.04 Termination of Paying Agent/Registrar. The City reserves the right to terminate the appointment of any Paying Agent/Registrar by delivering to the entity whose appointment is to be terminated a certified copy of a resolution of the City (i) giving notice of the termination of the appointment, stating the effective date of such termination, and (ii) appointing a successor Paying Agent/Registrar.

Section 5.05 Notice of Change of Paying Agent/Registrar to Owners. Promptly upon each change in the entity serving as Paying Agent/Registrar, the City will cause notice of the change to be sent to each Owner by United States mail, first-class, postage prepaid, at the address in the Register, stating the effective date of the change and the name and mailing address of the replacement Paying Agent/Registrar.

Section 5.06 Agreement of Paying Agent/Registrar to Perform Duties and Functions. By accepting the appointment as Paying Agent/Registrar, the Paying Agent/Registrar is deemed to have agreed to the provisions of this Ordinance and that it will perform the duties and functions of Paying Agent/Registrar prescribed hereby.

Section 5.07 Delivery of Records to Successor. If a Paying Agent/Registrar is replaced, such Paying Agent/Registrar, promptly upon the appointment of the successor, will deliver the Register (or a copy thereof) and all other pertinent books and records relating to the Bonds to the successor Paying Agent/Registrar.

## ARTICLE 6

### FORM OF THE BONDS

Section 6.01 Form Generally.

(a) The Bonds of each series, including the Registration Certificate of the Comptroller of Public Accounts of the State of Texas, the Certificate of the Paying Agent/Registrar, and the Assignment to appear on each of the Bonds, (i) shall be substantially in the form set forth in **Exhibit B** attached hereto with such appropriate insertions, omissions, substitutions, and other variations as are permitted or required by this Ordinance, with the Bonds to be completed and modified with the information set forth in the Pricing Certificate, and (ii) may have such letters, numbers, or other marks of identification (including identifying numbers and letters of the

Committee on Uniform Securities Identification Procedures of the American Bankers Association) and such legends and endorsements (including any applicable statement of insurance and any reproduction of an opinion of counsel) thereon as, consistently herewith, may be determined by the City or by the officers executing such Bonds, as evidenced by their execution thereof. Each Pricing Certificate shall set forth the final and controlling terms of the respective series of Bonds. Any portion of the text of any Bonds may be set forth on the reverse side thereof, with an appropriate reference thereto on the face of the Bonds.

(b) The definitive Bonds shall be typewritten, printed, lithographed, or engraved, and may be produced by any combination of these methods or produced in any other similar manner, all as determined by the officers executing such Bonds, as evidenced by their execution thereof. The Initial Bond submitted to the Attorney General of the State of Texas may be typewritten and photocopied or otherwise reproduced.

Section 6.02 Form of the Bonds. The form of each series of Bonds, including the form of the Registration Certificate of the Comptroller of Public Accounts of the State of Texas (which shall only appear on the Initial Bond), the form of Certificate of the Paying Agent/Registrar and the form of Assignment appearing on each series of Bonds shall be substantially in the form of attached **Exhibit B**.

Section 6.03 CUSIP Registration. The City may secure identification numbers through the CUSIP Service Bureau Division of Standard & Poor's Corporation, New York, New York, and may authorize the printing of such numbers on the face of the Bonds. It is expressly provided, however, that the presence or absence of CUSIP numbers on the Bonds shall be of no significance or effect as regards the legality thereof and neither the City nor the attorneys approving such Bonds as to legality are to be held responsible for CUSIP numbers incorrectly printed on the Bonds.

Section 6.04 Legal Opinion. The approving legal opinion of Bond Counsel may be attached to or printed on each Bond over the certification of the City Clerk or Alternate City Clerk of the City, which certification may be executed in facsimile.

Section 6.05 Statement of Insurance. A statement relating to a municipal bond insurance policy, if any, to be issued for the Bonds may be printed on or attached to each Bond.

## ARTICLE 7

### PUBLIC SERVICE BOARD

#### Section 7.01 Public Service Board.

(a) Pursuant to the authority contained in Texas Government Code, Section 1502.071, as amended, during such time as any of the Bonds herein authorized are outstanding and unpaid, the Board shall have complete authority and control of the management and operation of the System.

(b) The Board shall consist of seven members, one of whom shall be the Mayor of the City who shall ex officio be one member of the Board. Each term of office shall be four years with no member being appointed to more than two consecutive terms. To the extent not prohibited

by State law or in conflict with the ordinances authorizing the Bonds Similarly Secured, each member shall continue to serve until his or her successor is appointed and qualified, or until 30 days have passed beyond the expiration of such term, whichever event occurs first. After that time a vacancy on the Board shall exist and the former member shall have no power to vote or participate in Board proceedings; but such vacancy shall not serve to reduce the number of members required for a quorum.

Each vacancy in Board membership whether occasioned by expiration of office or otherwise shall be filled by the City Council from three persons eligible to serve as Board members and presented to City Council. A selection committee selected by the City Council and comprised of the Board and such additional members as appointed by City Council shall agree upon and submit to City Council the names of such three eligible persons.

Any member of the Board, other than the Mayor, who shall be continuously absent from all meetings of the Board for a period of three consecutive months shall, unless he or she shall be granted leave of absence by the unanimous vote of the remaining members of the Board, be removed from office, but only for adequate cause. As City Council appointees, members of the Board are subject to the City's ethics ordinance, Chapter 2.92 of the City Code of the City, as amended, and must comply with the applicable provisions contained therein.

(c) The Board shall elect one of its own members as Chairman and one as Vice-Chairman and appoint a Secretary and a Treasurer or a Secretary-Treasurer, who may, but need not, be a member or members of the Board. The Board may make such regulations or any by-laws for the orderly handling of its affairs as it may in its discretion see fit and shall thereafter, subject to the pertinent laws of the State of Texas, operate and manage the System with the same freedom and in the same manner as are ordinarily enjoyed by the Board of Directors of a private corporation operating properties of a similar nature.

Subject to the provisions and restrictions contained in this Ordinance, all of which shall be binding on the Board, the Board shall have complete authority and control of the management and operations of the System and the expenditure and application of its revenues.

(d) The Board shall elect or appoint all officers and employees which it may consider desirable, including a President/Chief Executive Officer of the EPWU. The President/Chief Executive Officer shall be responsible to appoint officers and employees that directly report to the President/Chief Executive Officer, including, an attorney or attorneys, vice president(s) and such other personnel that directly report to the President/Chief Executive Officer. All other officers and employees, except members of the Board, the President/Chief Executive Officer, attorneys, vice president(s) and persons directly reporting to the President/Chief Executive Officer or vice president(s) shall serve under the City Civil Service provisions as are or may be established by the Charter of the City or the laws of Texas, and the Board shall have the same authority with respect to such officers and employees as that of the City Council with respect to other officers and other employees of the City. The Board shall obtain and keep continually in force an employers' fidelity and indemnity bond of the so-called blanket type, written by a solvent and recognized indemnity company, and covering losses to the amount not to exceed \$50,000.



(e) The members of the Board, other than the Mayor shall, for each meeting attended, receive the sum of \$20.00, except that the amount so paid to any member of the Board in any fiscal year shall not exceed \$5,000. The members of the Board shall not personally be liable for any act or omission not willfully fraudulent or committed in bad faith.

## ARTICLE 8

### FUNDS; FLOW OF FUNDS

#### Section 8.01 Special Funds.

(a) The City covenants and agrees that all revenues derived from the operation of the System shall be kept separate from other funds of the City. To that end, the following special funds heretofore established are hereby reaffirmed and shall be maintained at the Depository Bank so long as any of the Bonds Similarly Secured are Outstanding, to-wit:

(i) “City of El Paso, Texas, Municipal Drainage Utility System Revenue Fund” (herein called the “Revenue Fund”);

(ii) “City of El Paso, Texas, Municipal Drainage Utility System Bonds Interest and Sinking Fund” (herein called the “Interest and Sinking Fund”);

(iii) “City of El Paso, Texas, Municipal Drainage Utility System Bonds Reserve Fund” (herein called the “Reserve Fund”); and

(iv) “City of El Paso, Texas, Municipal Drainage Utility System Improvement Fund” (herein called the “Improvement Fund”).

The Interest and Sinking Fund and the Reserve Fund shall be held in trust solely for the benefits of the Owners and the Owners of the Bonds Similarly Secured.

(b) The “City of El Paso, Texas Municipal Drainage Utility System Revolving Note Payment Fund” (the “Note Payment Fund”) heretofore created by the ordinance authorizing the City’s Tax-Exempt Revolving Notes, Series A and Taxable Revolving Notes, Series B, herein referred to as the “Subordinate Lien Obligations,” is hereby reaffirmed.

Section 8.02 Revenue Fund. All Revenues shall be deposited from day to day as collected into the Revenue Fund. Moneys on deposit in the Revenue Fund shall first be used to pay all Operating and Maintenance Expenses. The Revenues of the System not actually required to pay Operating and Maintenance Expenses (the “Net Revenues”) shall be transferred from the Revenue Fund to the other Funds in this Ordinance, in the order of priority, in the manner, and in the amounts set forth below:

(a) Interest and Sinking Fund. In addition to the deposits required by ordinances authorizing the Previously Issued Bonds, there shall be deposited into the Interest and Sinking Fund the following:

(i) such amounts, in equal monthly installments, commencing on the first day of the month next following the Closing Date, and on the first day of each month thereafter, as will be sufficient to pay the interest scheduled to come due on the Bonds on the next

interest payment date, less any amounts already on deposit therein for such purpose derived from the proceeds of the Bonds or from any other lawfully available source; and

(ii) such amounts, in equal monthly installments, commencing on the first day of the month next following the Closing Date, and on the first day of each month thereafter, as will be sufficient to pay the next maturing principal of the Bonds, including any scheduled mandatory redemption of Bonds.

The Interest and Sinking Fund shall be used to pay the principal of and interest on the Bonds Similarly Secured as such principal matures and such interest becomes due.

(b) Reserve Fund. So long as the funds on deposit in the Reserve Fund created for the benefit of the Bonds Similarly Secured are equal to the Reserve Fund Requirement, no deposits need to be made to the credit of the Reserve Fund; but should the Reserve Fund at any time contain less than the Reserve Fund Requirement, then, subject and subordinate to making the required deposits to the credit of the Interest and Sinking Fund, the City shall transfer from the Net Revenues in the Revenue Fund and deposit to the credit of the Reserve Fund, on the first day of each month, such amounts in equal monthly installments to accumulate within sixty (60) months a sum equal to the Reserve Fund Requirement. The money on deposit in the Reserve Fund may be used to pay the principal of and interest on the Bonds Similarly Secured at any time there are not sufficient funds on deposit in the Interest and Sinking Fund for such purpose.

In accordance with the procedures specified in the preceding paragraph, the City hereby directs that the deposits, if any, being made to the Reserve Fund be increased to accumulate in the Reserve Fund within sixty (60) months from the date of the Bonds an amount equal to the Reserve Fund Requirement.

Notwithstanding anything herein to the contrary, the City retains the right, with respect to the Bonds and subsequent issues of Additional Bonds to fund the Reserve Fund Requirement in whole or in part with a surety bond or insurance policy issued by an insurance company or other entity that is rated either for the long term unsecured debt of the issuer of such surety bond or for obligations insured, secured or guaranteed by such issuer have a rating in the highest letter category by two major municipal securities rating or evaluation services, and money deposited to the credit of the Reserve Fund may be used to make any payments required to satisfy the City's repayment obligation to the issuer of such surety bond or insurance policy in the same manner and with like effect as if such payments were being used to accumulate, maintain or restore the Reserve Fund Requirement in cash or with authorized investments.

(c) Note Payment Fund. In addition to the foregoing deposits, in order to provide for the payment of and security for any Subordinate Lien Obligations there shall be deposited to the Note Payment Fund amounts sufficient to pay when due the principal of and interest on the Subordinate Lien Obligations.

(d) Improvement Fund. All money remaining in the Revenue Fund at the end of each month after all payments required to be made therefrom in such month have been made and all deficiencies accumulated from prior months have been remedied shall continue to be paid to the Improvement Fund established in connection with the System, and shall be held in and paid out from such Fund for the following purposes:

(i) To pay the cost of any special or extraordinary repairs or replacements to or of the properties comprising the System, properly payable with such money under the laws of the State of Texas, necessitated by reason of some emergency; and

(ii) To the extent now or hereafter permitted by law, any lawful purpose.

Section 8.03 Investment of Funds.

(a) Money deposited to the credit of any Fund referenced in this Ordinance may, at the option of the City, be invested in obligations identified in, and in accordance with the provisions of the “Public Funds Investment Act” (Texas Government Code, Chapter 2256, as amended) relating to the investment of “bond proceeds”; provided that all such investments shall be made in such a manner that the money required to be expended from such Funds will be available at the proper time or times. Such investments (except State and Local Government Series investments held in book entry form, which shall at all times be valued at cost) shall be valued in terms of current market value within 45 days of the close of each Fiscal Year and, with respect to investments held for the account of the Reserve Fund, within 30 days of the date of passage of each ordinance authorizing the issuance of Additional Bonds. All interest and income derived from deposits and investments in the Interest and Sinking Fund immediately shall be credited to, and any losses debited to, the Interest and Sinking Fund. All interest and interest income derived from deposits in and investments of the Reserve Fund shall, subject to the limitations provided in Section 8.02(b) hereof, be credited to and deposited in the Revenue Fund. All such investments shall be sold promptly when necessary to prevent any default in connection with the Bonds.

All moneys on deposit in the funds for which this Ordinance makes provision (except any portion thereof as may be at any time properly invested) shall be secured in the manner and to the fullest extent required by the laws of Texas for the security of public funds.

Section 8.04 Contributions in Aid of Construction. Any moneys that may be received by the Board that shall represent contributions in aid of construction shall be deposited in a separate account at the Depository Bank. Such contributions shall not be considered as part of the Revenues of the System. Payments from such bank account shall be made only for the purposes for which the contributions were made, including any refunds that may become due to any contributor.

## ARTICLE 9

### DEPOSIT OF PROCEEDS; CONTROL AND DELIVERY OF BONDS

Section 9.01 Deposit of Proceeds.

(a) The proceeds of sale of each series of Bonds shall be disbursed by the Paying Agent/Registrar on the Closing Date pursuant to written instructions from the City’s Financial Advisor.

(b) All amounts, if any, received on the Closing Date as accrued interest on the Bonds shall be deposited to the Interest and Sinking Fund.

(c) Bond proceeds, less the accrued interest, if any, referenced in the preceding paragraph, amounts to pay costs of issuance and amounts to pay municipal bond insurance premium, if any, shall be deposited as provided in the applicable Pricing Certificate.

Section 9.02 Control and Delivery of Bonds.

(a) The Mayor, or in his absence, the Mayor Pro-Tem, is hereby authorized to have control of the Initial Bond and all necessary records and proceedings pertaining thereto pending investigation, examination and approval of the Attorney General of the State of Texas, registration by the Comptroller of Public Accounts of the State of Texas, and registration with, and initial exchange or transfer by, the Paying Agent/Registrar.

(b) After registration by the Comptroller of Public Accounts, delivery of the Bonds shall be made to the Purchaser under and subject to the general supervision of the City Manager of the City or the President/Chief Executive Officer of the EPWU against receipt by the City of all amounts due the City under the terms of the sale.

ARTICLE 10

PARTICULAR REPRESENTATIONS AND COVENANTS

Section 10.01 Insurance. The City hereby agrees that it will carry at all times for the benefit of the Owners of the Bonds, such insurance on the System that is reasonably obtainable of the kinds and in the amounts which are usually carried by private companies operating similar properties. Such insurance may be provided by means of a self-insurance fund in which event deposits to such fund shall be a maintenance and operating expense of the System.

Section 10.02 Books and Records. The City hereby covenants and agrees that complete and proper books of records and account will be kept and that the Owners of any of the Bonds, or any duly authorized agent or agents of such Owners, shall have the right to inspect such records at all reasonable times. The Board will within sixty (60) days following the close of each fiscal year, cause an audit of the books and accounts to be made by an independent firm of certified public accountants and that such audit will be available for inspection by the Owners of any of the Bonds.

Section 10.03 Additional Covenants.

(a) Additional Bonds. The City may issue “Additional Bonds” if the following conditions are met:

(i) the City is not then in default as to any covenant, condition or obligation prescribed by an ordinance authorizing the issuance of any bonds payable from and secured by a first lien on and pledge of the Net Revenues;

(ii) the Additional Bonds are made to mature on March 1 or September 1 in each of the years in which they are scheduled to mature;

(iii) the City has secured a certificate or opinion of a Certified Public Accountant to the effect that, according to the books and records of the City, the Net Revenues for the last completed Fiscal Year, or for 12 consecutive months out

of the 15 months, immediately preceding the date of issuance of the Additional Bonds (the date of issuance being the date of delivery of all or a portion of the Additional Bonds to the initial purchasers) are at least equal to 1.25 times the Average Annual Debt Service for all Outstanding Bonds Similarly Secured after giving effect to the issuance of the Additional Bonds then being issued. In making a determination of the Net Revenues, the Accountant may take into consideration a change in the charges for services afforded by the System that became effective at least sixty (60) days prior to the last day of the period for which Revenues are determined and, for purposes of satisfying the above Revenues test, make a pro forma determination of the Net Revenues of the System for the period of time covered by his certification or opinion based on such change in charges being in effect for the entire period covered by the certificate or opinion of the Accountant; and

(iv) the Reserve Fund Requirement shall be increased as necessary and any such additional amount shall be accumulated in equal monthly installments during a period not to exceed sixty (60) months.

(b) Refunding Bonds. The City reserves the right to issue refunding bonds to refund all or any part of the Bonds Similarly Secured (pursuant to any law then available) upon such terms and conditions as the City Council of the City may deem to be in the best interest of the City and its inhabitants, and if less than all such Bonds Similarly Secured then Outstanding are refunded, the conditions precedent prescribed (for the issuance of Additional Bonds) set forth in subparagraph (a)(iii) of this Section shall be satisfied and the certificate of the Accountant required in subparagraph (a)(iii) shall give effect to the Debt Service requirements of the proposed refunding bonds (and shall not give effect to the Debt Service requirements of the Bonds Similarly Secured being refunded following their cancellation or provision being made for their payment).

(c) Obligations of Inferior Lien and Pledge. The City hereby reserves the right to issue obligations payable from and secured by a lien on and pledge of the Net Revenues of the System, junior and subordinate in rank and dignity to the lien and pledge securing the payment of the Bonds Similarly Secured, as may be authorized by the laws of the State of Texas.

(d) Maintain and Operate System Efficiently. The City and the Board hereby covenant, respectively, that they will maintain and operate the System with all possible efficiency, in good working order and at a reasonable cost while any of the Bonds remain Outstanding and faithfully and punctually perform all duties with reference to the System required by the Constitution and laws of the State.

(e) Rate Covenant. The Board hereby covenants that it will establish and maintain rates for services supplied by the System which shall produce or yield Net Revenues equal to 1.25 times the Average Annual Debt Service requirements of all Bonds Similarly Secured.

(f) Debt Service Coverage Ratio. The Board hereby covenants that each Fiscal Year while the Bonds are Outstanding, it will operate the System in a manner that results in the Net Revenues equaling 1.25 times the Average Annual Debt Service requirements of all Bonds Similarly Secured.

(g) Charges for Water and Sewer and Drainage Service. The City and the Board hereby covenant that charges for drainage services will be made jointly with charges made for the sale of water and sewer services. Such charges shall be required to be paid by the customer at the same time.

(h) Enforcement. To exercise and pursue with due diligence available remedies provided by law for the collection of delinquent drainage charges, including the power under Section 552.050 of the Act to discontinue all utility services, particularly water and sewer services provided by the City to a user of benefited property who is delinquent in the payment of drainage charges.

(i) Nonimpairment of Lien. The City and the Board hereby covenant, respectively, to take no action or omit to take any action, or suffer to be done or omitted to be done, any matter or thing whatsoever whereby the lien of the Bonds Similarly Secured on the Net Revenues of the System might or could be lost or impaired, and that the Board will pay or cause to be paid, or will make adequate provision for the satisfaction and discharge of all lawful claims and demands for labor, materials, supplies, or other objects which, if unpaid, might by law be given precedence to, or an equality with the Bonds Similarly Secured as a lien or charge upon the revenues of the System or any part thereof; provided that nothing in this subsection (i) shall be construed to require the Board to pay, discharge or make provision for any such lien, charge, claim or demand so long as the validity thereof shall be by it in good faith contested.

(j) No Sale or Encumbrance of System. The City and the Board hereby covenant, respectively, that they will not in any manner dispose of the System or any substantial part thereof, including any and all extensions and additions that may be made thereto, until the Bonds Similarly Secured shall have been paid in full as to both principal and interest; provided, however, that this covenant shall not be construed to prevent the disposal by the City of property, which in the Board's judgment has become inexpedient to use in connection with the System, when other property of equal value is substituted therefor or when the proceeds of such disposition of such property are placed in the Interest and Sinking Fund, in addition to all other amounts required to be placed in the Interest and Sinking Fund in the current fiscal year, and are used for the retirement of Bonds Similarly Secured in advance of their respective maturities.

(k) No Competing Systems. The City hereby covenants that it will not grant a franchise for the operation of any competing drainage system in the City until all Bonds Similarly Secured have been paid in full with respect to principal and interest.

(l) No Free Service. The Board hereby covenants that it will not permit free drainage to be supplied to the City or to any other user (other than those persons exempt under the Act and/or applicable law) and the City hereby agrees that it will pay from its general fund the reasonable value of all drainage services obtained from the System by the City and all departments and agencies thereof.

Section 10.04 Payment of Bonds. While any of the Bonds are Outstanding, the Chief Financial Officer of the EPWU shall cause to be transferred to the Paying Agent/Registrar therefor, from funds on deposit in the Interest and Sinking Fund, and, if necessary, in the Reserve Fund, amounts sufficient to fully pay and discharge promptly as each installment of principal of the

Bonds accrues or matures or comes due by reason of redemption prior to maturity; such transfer of funds to be made in such manner as will cause immediately available funds to be deposited with the Paying Agent/Registrar for the Bonds at the close of the business day next preceding the date of payment for the Bonds.

## ARTICLE 11

### COVENANTS TO MAINTAIN TAX EXEMPT STATUS

#### Section 11.01 Covenants to Maintain Tax Exempt Status.

(a) Definitions. When used in this Section, the following terms shall have the following meanings:

“Closing Date” means the date on which the Bonds are first authenticated and delivered to the initial purchasers against payment therefor.

“Code” means the Internal Revenue Code of 1986, as amended by all legislation, if any, effective on or before the Closing Date.

“Computation Date” has the meaning set forth in Section 1.148-1(b) of the Regulations.

“Gross Proceeds” means any proceeds as defined in Section 1.148-1(b) of the Regulations, and any replacement proceeds as defined in Section 1.148-1(c) of the Regulations, of the Bonds.

“Investment” has the meaning set forth in Section 1.148-1(b) of the Regulations.

“Nonpurpose Investment” means any investment property, as defined in Section 148(b) of the Code, in which Gross Proceeds of the Bonds are invested and which is not acquired to carry out the governmental purposes of the Bonds.

“Rebate Amount” has the meaning set forth in Section 1.148-1(b) of the Regulations.

“Regulations” means any proposed, temporary, or final Income Tax Regulations issued pursuant to Sections 103 and 141 through 150 of the Code, and 103 of the Internal Revenue Code of 1954, which are applicable to the Bonds. Any reference to any specific Regulation shall also mean, as appropriate, any proposed, temporary or final Income Tax Regulation designed to supplement, amend or replace the specific Regulation referenced.

“Yield” of (1) any Investment has the meaning set forth in Section 1.148-5 of the Regulations and (2) the Bonds has the meaning set forth in Section 1.148-4 of the Regulations.

(b) Not to Cause Interest to Become Taxable. The City shall not use, permit the use of, or omit to use Gross Proceeds or any other amounts (or any property the acquisition, construction or improvement of which is to be financed directly or indirectly with Gross Proceeds) in a manner which, if made or omitted, respectively, would cause interest on any Bond issued hereunder to become includable in the gross income, as defined in Section 61 of the Code, of the owner thereof for federal income tax purposes. Without limiting the generality of the foregoing, unless and until the City receives a written opinion of counsel nationally recognized in the field of municipal bond law to the effect that failure to comply with such covenant will not adversely affect the exemption from federal income tax of the interest on any Bond, the City shall comply with each of the specific covenants in this Section.

(c) No Private Use or Private Payments. Except as permitted by Section 141 of the Code and the Regulations and rulings thereunder, the City shall at all times prior to the last stated maturity of the Bonds:

(i) exclusively own, operate and possess all property the acquisition, construction or improvement of which is to be financed or refinanced directly or indirectly with Gross Proceeds of the Bonds (including property financed with Gross Proceeds of the Refunded Revolving Notes), and not use or permit the use of such Gross Proceeds (including all contractual arrangements with terms different than those applicable to the general public) or any property acquired, constructed or improved with such Gross Proceeds in any activity carried on by any person or entity (including the United States or any agency, department and instrumentality thereof) other than a state or local government, unless such use is solely as a member of the general public; and

(ii) not directly or indirectly impose or accept any charge or other payment by any person or entity who is treated as using Gross Proceeds of the Bonds (including property financed with Gross Proceeds of the Refunded Revolving Notes) or any property the acquisition, construction or improvement of which is to be financed or refinanced directly or indirectly with such Gross Proceeds, other than taxes of general application within the City or interest earned on investments acquired with such Gross Proceeds pending application for their intended purposes.

(d) No Private Loan. Except to the extent permitted by Section 141 of the Code and the Regulations and rulings thereunder, the City shall not use Gross Proceeds of the Bonds to make or finance loans to any person or entity other than a state or local government. For purposes of the foregoing covenant, such Gross Proceeds are considered to be “loaned” to a person or entity if: (1) property acquired, constructed or improved with such Gross Proceeds is sold or leased to such person or entity in a transaction which creates a debt for federal income tax purposes; (2) capacity in or service from such property is committed to such person or entity under a take or pay, output or similar contract or arrangement; or (3) indirect benefits, or burdens and benefits of ownership, of such Gross Proceeds or any property acquired, constructed or improved with such Gross Proceeds are otherwise transferred in a transaction which is the economic equivalent of a loan.

(e) Not to Invest at Higher Yield. Except to the extent permitted by Section 148 of the Code and the Regulations and rulings thereunder, the City shall not at any time prior to the final



stated maturity of the Bonds directly or indirectly invest Gross Proceeds in any Investment (or use Gross Proceeds to replace money so invested), if as a result of such investment the Yield from the Closing Date of all Investments acquired with Gross Proceeds (or with money replaced thereby), whether then held or previously disposed of, exceeds the Yield of the Bonds.

(f) Not Federally Guaranteed. Except to the extent permitted by Section 149(b) of the Code and the Regulations and rulings thereunder, the City shall not take or omit to take any action which would cause the Bonds to be federally guaranteed within the meaning of Section 149(b) of the Code and the Regulations and rulings thereunder.

(g) Information Report. The City shall timely file the information required by Section 149(e) of the Code with the Secretary of the Treasury on Form 8038-G or such other form and in such place as the Secretary may prescribe.

(h) Rebate of Arbitrage Profits. Except to the extent otherwise provided in Section 148(f) of the Code and the Regulations and rulings thereunder:

(i) The City shall account for all Gross Proceeds (including all receipts, expenditures and investments thereof) on its books of account separately and apart from all other funds (and receipts, expenditures and investments thereof) and shall retain all records of accounting for at least six years after the day on which the last Outstanding Bond is discharged. However, to the extent permitted by law, the City may commingle Gross Proceeds of the Bonds with other money of the City, provided that the City separately accounts for each receipt and expenditure of Gross Proceeds and the obligations acquired therewith.

(ii) Not less frequently than each Computation Date, the City shall calculate the Rebate Amount in accordance with rules set forth in Section 148(f) of the Code and the Regulations and rulings thereunder. The City shall maintain such calculations with its official transcript of proceedings relating to the issuance of the Bonds until six years after the final Computation Date.

(iii) As additional consideration for the purchase of the Bonds by the Purchaser and the loan of the money represented thereby and in order to induce such purchase by measures designed to insure the excludability of the interest thereon from the gross income of the owners thereof for federal income tax purposes, the City shall pay to the United States out of the Interest and Sinking Fund or its general fund, as permitted by applicable Texas statute, regulation or opinion of the Attorney General of the State of Texas, the amount that when added to the future value of previous rebate payments made for the Bonds equals (i) in the case of a Final Computation Date as defined in Section 1.148-3(e)(2) of the Regulations, one hundred percent (100%) of the Rebate Amount on such date; and (ii) in the case of any other Computation Date, ninety percent (90%) of the Rebate Amount on such date. In all cases, the rebate payments shall be made at the times, in the installments, to the place and in the manner as is or may be required by Section 148(f) of the Code and the Regulations and rulings thereunder, and shall be accompanied by Form 8038-T or such other forms and information as is or may be required by Section 148(f) of the Code and the Regulations and rulings thereunder.

(iv) The City shall exercise reasonable diligence to assure that no errors are made in the calculations and payments required by paragraphs (ii) and (iii), and if an error is made, to discover and promptly correct such error within a reasonable amount of time thereafter (and in all events within one hundred eighty (180) days after discovery of the error), including payment to the United States of any additional Rebate Amount owed to it, interest thereon, and any penalty imposed under Section 1.148 3(h) of the Regulations.

(i) Not to Divert Arbitrage Profits. Except to the extent permitted by Section 148 of the Code and the Regulations and rulings thereunder, the City shall not, at any time prior to the earlier of the stated maturity or final payment of the Bonds, enter into any transaction that reduces the amount required to be paid to the United States pursuant to subsection (h) of this Section because such transaction results in a smaller profit or a larger loss than would have resulted if the transaction had been at arm's length and had the Yield of the Bonds not been relevant to either party.

(j) Elections. The City hereby directs and authorizes the City Manager, the President/Chief Executive Officer of the EPWU, the Vice President of Strategic, Financial and Management Services of the EPWU and/or the Chief Financial Officer of the EPWU, either or any combination of them, to make elections permitted or required pursuant to the provisions of the Code or the Regulations, as they deem necessary or appropriate in connection with the Bonds, in the Certificate as to Tax Exemption or similar or other appropriate certificate, form or document.

(k) Bonds Not Hedge Bonds. (1) At the time the original obligations refunded by the Bonds were issued, the City reasonably expected to spend at least 85% of the spendable proceeds of such original obligations within three years after such obligations were issued and (2) not more than 50% of the proceeds of the original obligations refunded by the Bonds were invested in Nonpurpose Investments having a substantially guaranteed Yield for a period of 4 years or more.

(l) Current Refunding. The payment and discharge of the Refunded Revolving Notes will occur within ninety (90) days after the issuance of the Bonds and, therefore, the portion of the Bonds issued to refund such obligations are a current refunding.

Section 11.02 Continuing Obligation. Notwithstanding any other provision of this Ordinance, the City's obligations under the covenants and provisions of this Article 11 shall survive the defeasance and discharge of the Bonds.

## ARTICLE 12

### DEFAULT AND REMEDIES

Section 12.01 Remedies in Event of Default. In addition to all the rights and remedies provided by the laws of the State of Texas, the City covenants and agrees particularly that in the event the City (a) defaults in payments to be made to the Interest and Sinking Fund or the Reserve Fund as required by the Ordinance, or (b) defaults in the observance or performance of any other of the covenants, conditions or obligations set forth in the Ordinance, the Owner or Owners of any of the Bonds shall be entitled to a writ of mandamus issued by a court of proper jurisdiction, compelling and requiring the City and its officers to observe and perform any covenant, condition

or obligation prescribed in the Ordinance. No delay or omission to exercise any right or power accruing upon any default shall impair any such right or power, nor shall such delay or omission be construed to be a waiver of any such default or acquiescence therein, and every such right and power may be exercised from time to time and as often as may be deemed expedient.

Section 12.02 Remedies Not Exclusive. No remedy herein conferred or reserved is intended to be exclusive of any other available remedy or remedies, but each and every such remedy shall be cumulative and shall be in addition to every other remedy given hereunder or under the Bonds or now or hereafter existing at law or in equity; provided, however, that notwithstanding any other provision of this Ordinance, the right to accelerate the debt evidenced by the Bonds shall not be available as a remedy under this Ordinance.

The exercise of any remedy herein conferred or reserved shall not be deemed a waiver of any other available remedy.

## ARTICLE 13

### DISCHARGE

Section 13.01 Discharge. If the City shall pay or cause to be paid, or there shall otherwise be paid to the Owners, the principal of, premium, if any, and interest on the Bonds, at the times and in the manner stipulated in this Ordinance, then the pledge of Net Revenues of the System under this Ordinance and all covenants, agreements, and other obligations of the City to the Owners shall thereupon cease, terminate, and be discharged and satisfied.

Bonds or any principal amount(s) thereof shall be deemed to have been paid within the meaning and with the effect expressed in this Section when (i) money sufficient to pay in full such Bonds or the principal amount(s) thereof at maturity, together with all interest due thereon, shall have been irrevocably deposited with and held in trust by the Paying Agent/Registrar, or an authorized escrow agent or (ii) Government Obligations shall have been irrevocably deposited in trust with the Paying Agent/Registrar, or an authorized escrow agent, which Government Obligations shall mature as to principal and interest in such amounts and at such times as will insure the availability, without reinvestment, of sufficient money, together with any moneys deposited therewith, if any, to pay when due the principal of and interest on such Bonds, or the principal amount(s) thereof, on and prior to the stated maturity thereof. In the event of a defeasance of the Bonds, the City shall deliver a certificate from its financial advisor, the Paying Agent/Registrar, an independent certified public accountant, or another qualified third party concerning the sufficiency of the deposit of cash and/or Government Obligations to pay, when due, the principal of, redemption premium (if any), and interest due on any defeased Bonds. The City covenants that no deposit of moneys or Government Obligations will be made under this Section and no use will be made of any such deposit which would cause the Bonds to be treated as "arbitrage bonds" within the meaning of Section 148 of the Code or the regulations adopted pursuant thereto.

All moneys so deposited with the Paying Agent/Registrar or an authorized escrow agent, and all income from Government Obligations held in trust by the Paying Agent/Registrar, or an authorized escrow agent, and all income from Government Obligations held in trust by the Paying

Agent/Registrar, or an authorized escrow agent, pursuant to this Section, which is not required for the payment of the Bonds, or any principal amount(s) thereof, or interest thereon with respect to which such moneys have been so deposited shall be remitted to the City or deposited as directed by the City. Furthermore, any money held by the Paying Agent/Registrar for the payment of the principal of and interest on the Bonds and remaining unclaimed for a period of three (3) years after the stated maturity of the Bonds such moneys were deposited and are held in trust to pay shall upon request of the City be remitted to the City against a written receipt therefor. The provisions of this paragraph are subject to the applicable unclaimed property law of the State of Texas.

The City reserves the right, subject to satisfying the requirements of (i) and (ii) above, to substitute other Government Obligations for the Government Obligations originally deposited, to reinvest the uninvested moneys on deposit for such defeasance and to withdraw for the benefit of the City moneys in excess of the amount required for such defeasance.

Upon such deposit as described above, such Bonds shall no longer be regarded to be outstanding or unpaid. Provided, however, the City has reserved the option, to be exercised at the time of the defeasance of the Bonds, to call for redemption, at an earlier date, those Bonds which have been defeased to their maturity date, if the City: (i) in the proceedings providing for the firm banking and financial arrangements, expressly reserves the right to call the Bonds for redemption; (ii) gives notice of the reservation of that right to the Owners immediately following the making of the firm banking and financial arrangements; and (iii) directs that notice of the reservation be included in any redemption notices that it authorizes.

## ARTICLE 14

### SALE AND DELIVERY OF BONDS; OFFICIAL STATEMENT

#### Section 14.01 Sale of Bonds - Official Statement.

(a) The Bonds authorized by this Ordinance may be sold by the City to the Purchaser by (i) negotiated sale, in accordance with one or more bond purchase agreements (each, a "Purchase Contract"), (ii) private placement, in accordance with one or more agreements to purchase or other agreement, or (iii) competitive bidding, in accordance with the successful bid(s) submitted therefor, as determined by the Pricing Officer, in accordance with Article 3 hereof. In the event the Bonds are sold by negotiated sale, the Pricing Officer shall designate and identify the Purchaser in the applicable Pricing Certificate. The Pricing Officer is hereby authorized and directed to execute the Purchase Contract, agreement(s) to purchase in the event of a private placement, or the successful bid form(s) in the event of a competitive sale, as applicable, for and on behalf of the City and as the act and deed of this City Council.

The Mayor, City Clerk and Alternate City Clerk of the City are further authorized and directed to manually or electronically execute and deliver for and on behalf of the City copies of a Preliminary Official Statement and Official Statement, prepared in connection with the offering of the Bonds by the Purchaser, in final form as may be required by the Purchaser, and such final Official Statement in the form and content as approved by the Pricing Officer or as manually or electronically executed by such officials shall be deemed to be approved by the City Council of the City and constitute the Official Statement authorized for distribution and use by the Purchaser.

(b) The City Manager, the President/Chief Executive Officer of the EPWU, the Vice President of Strategic, Financial and Management Services of the EPWU, the Chief Financial Officer of the EPWU or any other officer of the City are each authorized to execute such documents, certificates and receipts, and to make such elections with respect to the tax-exempt status of the Bonds, as they may deem appropriate in order to consummate the delivery of the Bonds in accordance with the provisions and terms of this Ordinance and the Pricing Certificate.

(c) The obligation of the Purchaser to accept delivery of the Bonds is subject to the Purchaser being furnished with the final, approving opinion of Norton Rose Fulbright US LLP, Bond Counsel for the City, which opinion shall be dated and delivered the Closing Date. The prior engagement of such firm as Bond Counsel to the City in connection with the issuance of its System revenue bonds is hereby approved and confirmed.

## ARTICLE 15

### CONTINUING DISCLOSURE UNDERTAKING

#### Section 15.01 Annual Reports.

(a) The City shall cause the Board to provide annually to the MSRB (1) within six months after the end of each fiscal year (beginning with the fiscal year stated in the Pricing Certificate) financial information and operating data with respect to the System of the general type included in the final Official Statement approved by the Pricing Officer and described in the Pricing Certificate, and (2) if not provided as part of such financial information and operating data, audited financial statements of the System, when and if available, and in any case within 12 months after the end of each fiscal year (beginning with the fiscal year stated in the Pricing Certificate). Any financial statements so to be provided shall be prepared in accordance with the accounting principles described in the Pricing Certificate, or such other accounting principles as the Board may be required to employ from time to time pursuant to state law or regulation, and audited, if the Board commissions an audit of such statements and the audit is completed within the period during which they must be provided. If audited financial statements are not available by the required time, the Board will provide unaudited financial statements by the required time and audited financial statements when and if such audited financial statements become available.

(b) If the Board changes its fiscal year, it will notify the MSRB of the change (and of the date of the new fiscal year end) prior to the next date by which the Board otherwise would be required to provide financial information and operating data pursuant to this Section.

(c) The financial information and operating data to be provided pursuant to this Section may be set forth in full in one or more documents or may be included by specific reference to any document available to the public on the MSRB's Internet Web site or filed with the SEC.

#### Section 15.02 Notice of Certain Events.

(a) The City will cause the Board to provide notice of any of the following events with respect to the Bonds to the MSRB in a timely manner and not more than 10 business days after occurrence of the event:

- (i) principal and interest payment delinquencies;
- (ii) non-payment related defaults, if material;
- (iii) unscheduled draws on debt service reserves reflecting financial difficulties;
- (iv) unscheduled draws on credit enhancements reflecting financial difficulties;
- (v) substitution of credit or liquidity providers, or their failure to perform;
- (vi) adverse tax opinions, the issuance by the Internal Revenue Service of proposed or final determinations of taxability, Notices of Proposed Issue (IRS Form 5701-TEB), or other material notices or determinations with respect to the tax status of the Bonds, or other material events affecting the tax status of the Bonds;
- (vii) modifications to rights of Owners of the Bonds, if material;
- (viii) bond calls, if material, and tender offers;
- (ix) defeasances;
- (x) release, substitution, or sale of property securing repayment of the Bonds, if material;
- (xi) rating changes;
- (xii) bankruptcy, insolvency, receivership, or similar event of the Board or City, which shall occur as described below;
- (xiii) the consummation of a merger, consolidation, or acquisition involving the Board or City or the sale of all or substantially all of its assets, other than in the ordinary course of business, the entry into of a definitive agreement to undertake such an action or the termination of a definitive agreement relating to any such actions, other than pursuant to its terms, if material;
- (xiv) appointment of a successor or additional trustee or the change of name of a trustee, if material;
- (xv) incurrence of a Financial Obligation of the Board, if material, or agreement to covenants, events of default, remedies, priority rights, or other similar terms of a Financial Obligation of the Board, any of which affect security holders, if material; and
- (xvi) default, event of acceleration, termination event, modification of terms, or other similar events under the terms of a Financial Obligation of the Board, any of which reflect financial difficulties.

For these purposes, (a) any event described in the immediately preceding paragraph (a)(xii) is considered to occur when any of the following occur: the appointment of a receiver, fiscal agent, or similar officer for the Board or City in a proceeding under the United States Bankruptcy Code or in any other proceeding under state or federal law in which a court or governmental authority has assumed jurisdiction over substantially all of the assets or business of the Board or City, or if

such jurisdiction has been assumed by leaving the existing governing body and officials or officers in possession but subject to the supervision and orders of a court or governmental authority, or the entry of an order confirming a plan of reorganization, arrangement, or liquidation by a court or governmental authority having supervision or jurisdiction over substantially all of the assets or business of the Board or City, and (b) the City intends the words used in the immediately preceding subsections (a)(xv) and (a)(xvi) and the definition of Financial Obligation in this Section to have the same meanings as when they are used in the Rule, as evidenced by SEC Release No. 34-83885, dated August 20, 2018.

(b) The City hereby instructs the Board to notify the MSRB, in a timely manner, of any failure by the Board to provide financial information or operating data in accordance with this Section by the time required by this Section.

Section 15.03 Filings with the MSRB. All financial information, operating data, financial statements, notices, and other documents provided to the MSRB in accordance with this Section shall be provided in an electronic format prescribed by the MSRB and shall be accompanied by identifying information as prescribed by the MSRB.

#### Section 15.04 Limitations, Disclaimers and Amendments

(a) The City, acting through the Board, shall be obligated to observe and perform the covenants specified in this Article with respect to the City, the Board and the Bonds while, but only while, the City or the Board remains an “obligated person” with respect to the Bonds within the meaning of the Rule, except that the City will cause the Board in any event to give notice required by Section 15.02 hereof of any Bond calls and defeasance that cause the City to be no longer such an “obligated person”.

(b) The provisions of this Section are for the sole benefit of the Owners and beneficial owners of the Bonds, and nothing in this Section, express or implied, shall give any benefit or any legal or equitable right, remedy, or claim hereunder to any other person. The City undertakes to provide only the financial information, operating data, financial statements, and notices which it has expressly agreed to provide pursuant to this Section and does not hereby undertake to provide any other information that may be relevant or material to a complete presentation of the financial results, condition, or prospects of the City or the State of Texas or hereby undertake to update any information provided in accordance with this Section or otherwise, except as expressly provided herein. The City does not make any representation or warranty concerning such information or its usefulness to a decision to invest in or sell Bonds at any future date.

UNDER NO CIRCUMSTANCES SHALL THE CITY BE LIABLE TO THE OWNER OR BENEFICIAL OWNER OF ANY BOND OR ANY OTHER PERSON, IN CONTRACT OR TORT, FOR DAMAGES RESULTING IN WHOLE OR IN PART FROM ANY BREACH BY THE BOARD OR THE CITY, WHETHER NEGLIGENT OR WITHOUT FAULT ON ITS PART, OF ANY COVENANT SPECIFIED IN THIS SECTION, BUT EVERY RIGHT AND REMEDY OF ANY SUCH PERSON, IN CONTRACT OR TORT, FOR OR ON ACCOUNT OF ANY SUCH BREACH SHALL BE LIMITED TO AN ACTION FOR MANDAMUS OR SPECIFIC PERFORMANCE.

(c) No default by the Board or the City in observing or performing its obligations under this Section shall constitute a breach of or default under this Ordinance for purposes of any other provision of this Ordinance.

(d) Nothing in this Section is intended or shall act to disclaim, waive, or otherwise limit the duties of the Board or the City under federal and state securities laws.

(e) Notwithstanding anything herein to the contrary, the provisions of this Section may be amended by the City from time to time to adapt to changed circumstances resulting from a change in legal requirements, a change in law, or a change in the identity, nature, status, or type of operations of the City or the Board, but only if (1) the provisions of this Section, as so amended, would have permitted an underwriter to purchase or sell Bonds in the primary offering of the Bonds in compliance with the Rule, taking into account any amendments or interpretations of the Rule to the date of such amendment, as well as such changed circumstances, and (2) either (a) the Owners of a majority in aggregate principal amount (or any greater amount required by any other provision of this Order that authorizes such an amendment) of the Outstanding Bonds consent to such amendment or (b) a Person that is unaffiliated with the City (such as nationally recognized bond counsel) determines that such amendment will not materially impair the interests of the Owners and beneficial owners of the Bonds. The provisions of this Section may also be amended from time to time or repealed by the City if the SEC amends or repeals the applicable provisions of the Rule or a court of final jurisdiction determines that such provisions are invalid, but only if and to the extent that reservation of the City's right to do so would not prevent underwriters of the initial public offering of the Bonds from lawfully purchasing or selling Bonds in such offering. If the City so amends the provisions of this Section, it shall include with any amended financial information or operating data next provided in accordance with subsection (b) an explanation, in narrative form, of the reasons for the amendment and of the impact of any change in the type of financial information or operating data so provided.

## ARTICLE 16

### PAYMENT OF REFUNDED REVOLVING NOTES; ESCROW AGENT

Section 16.01 Payment of Refunded Revolving Notes. Following the deposit of funds to the credit of the Note Payment Fund as specified in the Pricing Certificate, the Refunded Revolving Notes shall be payable solely from and secured by such deposits and shall cease to be payable from Net Revenues.

#### Section 16.02 Escrow Agreement.

(a) An "Escrow Agreement" (the "Escrow Agreement") by and between the City and an authorized escrow agent designated in the Pricing Certificate (the "Escrow Agent"), if any such agreement is required in connection with the issuance of the Bonds, shall be attached to and approved in the Pricing Certificate. Such Escrow Agreement is hereby authorized to be finalized and executed by the Pricing Officer for and on behalf of the City and as the act and deed of this City Council; and such Escrow Agreement as executed by such Pricing Officer shall be deemed approved by this City Council and constitute the Escrow Agreement herein approved. With regard to the finalization of certain terms and provisions of any Escrow Agreement, the Pricing Officer



is hereby authorized to come to an agreement with the Escrow Agent on the following details, among other matters:

1. The identification of the Refunded Revolving Notes;
2. The creation and funding of the Escrow Fund or Funds; and
3. The Escrow Agent's compensation, administration of the Escrow Fund or Funds, and the settlement of any paying agents' charges relating to the Refunded Revolving Notes.

Furthermore, appropriate officials of the City in cooperation with the Escrow Agent are hereby authorized and directed to make the necessary arrangements for the purchase of the escrowed securities referenced in the Escrow Agreement (the "Escrowed Securities"), if any, and the delivery thereof to the Escrow Agent on the day of delivery of the Bonds to the Purchaser for deposit to the credit of the "CITY OF EL PASO, TEXAS, MUNICIPAL DRAINAGE UTILITY SYSTEM REVENUE REFUNDING BONDS, SERIES 2023 ESCROW FUND" (referred to herein as the "Escrow Fund"), or such other designation as specified in the Pricing Certificate; all as contemplated and provided in Chapter 1207, the Ordinance, the Pricing Certificate and the Escrow Agreement. To the extent permitted by the Escrow Agreement and if the Pricing Officer determines such an arrangement is in the City's best interest, the Pricing Officer is authorized to direct the Escrow Agent to reinvest cash balances representing receipts from the Escrowed Securities, make substitutions of the Escrowed Securities or redeem the Escrowed Securities and reinvest the proceeds thereof in substituted Escrowed Securities and authorize the Escrow Agent to enter into any associated contract with a provider of such Escrowed Securities as long as any such substituted Escrowed Securities mature on the dates and in the amounts specified in a verification report as sufficient to pay the principal of and redemption premium, if any, and interest on the Refunded Revolving Notes when due. All Escrowed Securities delivered under such an arrangement shall be delivered to the Escrow Agent on a "delivery versus payment" basis. To the extent the Pricing Officer determines such an arrangement is in the City's best interest, the Pricing Officer is authorized to sign any associated contract, agreement, certificate or instruction letter with respect to such arrangement.

On or immediately prior to the date of the delivery of the Bonds to the Purchaser, the Pricing Officer, or other authorized City official, shall also cause to be deposited (and is hereby authorized to cause to be deposited) with the Escrow Agent from moneys on deposit in the debt service fund(s) maintained for the payment of the Refunded Revolving Notes an amount which, together with the proceeds of sale of the Bonds, and the investment earnings thereon, will be sufficient to pay in full the Refunded Revolving Notes (or the amount of accrued interest due thereon) on their scheduled maturity date (or the earliest date of payment, to be made from moneys in the Escrow Fund(s), as established in the Pricing Certificate, of the amount of accrued interest due thereon).

ARTICLE 17

MISCELLANEOUS

Section 17.01 Amendment to Ordinance.

(a) ***Amendments Without Consent.*** This Ordinance, the Pricing Certificate, and the rights and obligations of the City and of the owners of the Bonds may be modified or amended at any time without notice to or the consent of any owner of the Bonds or any other Previously Issued Bonds, solely for any one or more of the following purposes:

(i) To add to the covenants and agreements of the City contained in this Ordinance or the Pricing Certificate, other covenants and agreements thereafter to be observed, or to surrender any right or power reserved to or conferred upon the City in this Ordinance or the Pricing Certificate;

(ii) To cure any ambiguity or inconsistency, or to cure or correct any defective provisions contained in this Ordinance or the Pricing Certificate, upon receipt by the City of an opinion of nationally recognized bond counsel, that the same is needed for such purpose, and will more clearly express the intent of this Ordinance or the Pricing Certificate;

(iii) To supplement the security for the Bonds, replace or provide additional credit facilities, or change the form of the Bonds or make such other changes in the provisions hereof as the City may deem necessary or desirable and which shall not, in the judgment of the City, materially adversely affect the interests of the owners of the outstanding Bonds;

(iv) To make any changes or amendments requested by any bond rating agency then rating or requested to rate Bonds Similarly Secured, as a condition to the issuance or maintenance of a rating, which changes or amendments do not, in the judgment of the City, materially adversely affect the interests of the owners of the outstanding Bonds Similarly Secured; or

(v) To make such other changes in the provisions hereof as the City may deem necessary or desirable and which shall not, in the judgment of the City, materially adversely affect the interests of the owners of outstanding Previously Issued Bonds.

Notice of any such amendment may be published by the City in the manner described in subsection (c) of this Section; provided, however, that the publication of such notice shall not constitute a condition precedent to the adoption of such amendatory resolution and the failure to publish such notice shall not adversely affect the implementation of such amendment as adopted pursuant to such amendatory resolution.

(b) ***Amendments With Consent.*** Subject to the other provisions of this Ordinance, the owners of outstanding Bonds aggregating a majority in outstanding principal amount shall have the right from time to time to approve any amendment, other than amendments described in subsection (a) of this Section, to this Ordinance or the Pricing Certificate which may be deemed necessary or desirable by the City; provided, however, that nothing herein contained shall permit

or be construed to permit, without the approval of the owners of all of the outstanding Bonds, the amendment of the terms and conditions in this Ordinance, in the Pricing Certificate or in the Bonds so as to:

- (i) Make any change in the maturity of the outstanding Bonds;
- (ii) Reduce the rate of interest borne by outstanding Bonds;
- (iii) Reduce the amount of the principal payable on outstanding Bonds;
- (iv) Modify the terms of payment of principal of or interest on the outstanding Bonds, or impose any conditions with respect to such payment;
- (v) Affect the rights of the owners of less than all Bonds then outstanding; or
- (vi) Change the minimum percentage of the outstanding principal amount of Bonds necessary for consent to such amendment.

(c) **Notice.** If at any time the City shall desire to amend this Ordinance or the Pricing Certificate other than pursuant to subsection (a) of this Section, the City shall cause written notice of the proposed amendment to be given by certified mail to each registered owner of the Bonds affected at the address shown on the Register. Such notice shall briefly set forth the nature of the proposed amendment and shall state that a copy thereof is on file with the City Clerk or Alternate City Clerk for inspection by all owners of Bonds.

(d) **Consent Irrevocable.** Any consent given by any owner of Bonds pursuant to the provisions of this Section shall be irrevocable for a period of eighteen (18) months from the date of mailing of the notice provided for in this Section, and shall be conclusive and binding upon all future owners of the same Bonds during such period. Such consent may be revoked at any time after eighteen (18) months from the date of mailing by the owner who gave such consent, or by a successor in title, by filing notice thereof with the Paying Agent/Registrar and the City, but such revocation shall not be effective if the owners of a majority in outstanding principal amount of Bonds, prior to the attempted revocation, consented to and approved the amendment.

(e) **Ownership.** For the purpose of this Section, the ownership and other matters relating to all Bonds registered as to ownership shall be determined from the registration books kept by the Paying Agent/Registrar therefor. The Paying Agent/Registrar may conclusively assume that such ownership continues until written notice to the contrary is served upon the Paying Agent/Registrar.

Section 17.02 Further Procedures. The Mayor, Mayor Pro Tem, the City Clerk, the Alternate City Clerk, the City Manager of the City, the President/Chief Executive Officer of the EPWU, the Vice President of Strategic, Financial and Management Services of the EPWU, and/or the Chief Financial Officer of the EPWU and all other officers, employees and agents of the City, and each of them, shall be and they are hereby expressly authorized, empowered and directed from time to time and at any time to do and perform all such acts and things and to execute, acknowledge and deliver in the name and under the seal of the City and on behalf of the City all agreements, instruments, or such other documents, whether mentioned herein or not, as may be necessary or desirable in order to carry out the terms and provisions of this Ordinance, the initial sale and

delivery of the Bonds, and the Paying Agent/Registrar Agreement. In addition, prior to the initial delivery of the Bonds, the Mayor, Mayor Pro Tem, the City Clerk, the Alternate City Clerk, the City Manager of the City, the President/Chief Executive Officer of the EPWU, the Vice President of Strategic, Financial and Management Services of the EPWU or the Chief Financial Officer of the EPWU and the City's Bond Counsel are hereby authorized and directed to approve any technical changes or corrections to this Ordinance or to any of the instruments authorized and approved by this Ordinance: (i) in order to cure any technical ambiguity, formal defect, or omission in the Ordinance or such other document; or (ii) as requested by the Attorney General or his representative to obtain the approval of the Bonds by the Attorney General and if such officer or counsel determines that such ministerial changes are consistent with the intent and purpose of the Ordinance, which determination shall be final. In the event that any officer of the City whose signature shall appear on any document shall cease to be such officer before the delivery of such document, such signature nevertheless shall be valid and sufficient for all purposes the same as if such officer had remained in office until such delivery.

Additionally, the Mayor, Mayor Pro Tem, the City Clerk, the Alternate City Clerk, the City Manager of the City, the Chief Financial Officer of the City or the Pricing Officer may execute, authenticate, certify, or endorse or authorize to be executed, authenticated, certified, or endorsed with such officer's facsimile signature instead of the officer's manual signature any written agreement, including a contract, purchase order or surety bond, and any related document, including an application, certificate, or approval. For purposes of this Ordinance, "facsimile signature" means a reproduction of the manual signature of an authorized officer that is made by any method.

Section 17.03 Municipal Bond Insurance. The Bonds may be sold with the principal of and interest thereon being insured by a municipal bond insurance provider authorized to transact business in the State of Texas. The Pricing Officer is hereby authorized to make the selection of municipal bond insurance (if any) for the Bonds and make the determination of the provisions of any commitment therefor.

Section 17.04 Inconsistent Provisions. All ordinances, orders or resolutions, or parts thereof, which are in conflict or inconsistent with any provision of this Ordinance are hereby repealed to the extent of such conflict, and the provisions of this Ordinance shall be and remain controlling as to the matters contained herein.

Section 17.05 Governing Law. This Ordinance shall be construed and enforced in accordance with the laws of the State of Texas and the United States of America.

Section 17.06 Effectiveness. This Ordinance shall take effect and be in force from and after its passage and approval.

*[The remainder of this page intentionally left blank.]*

APPROVED AND ADOPTED this \_\_\_\_\_ day of \_\_\_\_\_, 2022.

\_\_\_\_\_  
Oscar Leeser  
Mayor, City of El Paso, Texas


ATTEST:

\_\_\_\_\_  
Laura D. Prine  
City Clerk, City of El Paso, Texas


(SEAL)

APPROVED AS TO FORM:

  
\_\_\_\_\_  
Paul A. Braden  
Bond Counsel

  
\_\_\_\_\_  
Karla Nieman  
City Attorney  
City of El Paso, Texas

APPROVED AS TO CONTENT:

  
\_\_\_\_\_  
Marcela Navarrete  
Vice President, Strategic, Financial  
and Management Services  
El Paso Water Utilities

**EXHIBIT A**  
**PAYING AGENT/REGISTRAR AGREEMENT**

## PAYING AGENT/REGISTRAR AGREEMENT

THIS AGREEMENT is entered into as of \_\_\_\_\_ (this "Agreement"), by and between \_\_\_\_\_, a national banking association duly organized and existing under the laws of the United States of America, or its successors (the "Bank") and the City of El Paso, Texas (the "Issuer").

### RECITALS

WHEREAS, the Issuer has duly authorized and provided for the issuance of its "City of El Paso, Texas, Municipal Drainage Utility System Revenue Refunding Bonds, Series 2023 (the "Securities")", dated \_\_\_\_\_, such Securities scheduled to be delivered to the initial purchasers thereof on or about \_\_\_\_\_; and

WHEREAS, the Issuer has selected the Bank to serve as Paying Agent/Registrar in connection with the payment of the principal of, premium, if any, and interest on said Securities and with respect to the registration, transfer and exchange thereof by the registered owners thereof; and

WHEREAS, the Bank has agreed to serve in such capacities for and on behalf of the Issuer and has full power and authority to perform and serve as Paying Agent/Registrar for the Securities;

NOW, THEREFORE, it is mutually agreed as follows:

### ARTICLE ONE APPOINTMENT OF BANK AS PAYING AGENT AND REGISTRAR

**Section 1.01 Appointment.** The Issuer hereby appoints the Bank to serve as Paying Agent with respect to the Securities, and, as Paying Agent for the Securities, the Bank shall be responsible for paying on behalf of the Issuer the principal, premium (if any), and interest on the Securities as the same become due and payable to the registered owners thereof; all in accordance with this Agreement and the "Authorizing Document" (hereinafter defined). The Issuer hereby appoints the Bank as Registrar with respect to the Securities and, as Registrar for the Securities, the Bank shall keep and maintain for and on behalf of the Issuer books and records as to the ownership of said Securities and with respect to the transfer and exchange thereof as provided herein and in the Authorizing Document.

The Bank hereby accepts its appointment, and agrees to serve as the Paying Agent and Registrar for the Securities.

**Section 1.02 Compensation.** As compensation for the Bank's services as Paying Agent/Registrar, the Issuer hereby agrees to pay the Bank the fees and amounts set forth in **Annex A** attached hereto; provided, however, notwithstanding anything herein or in Annex A to the contrary, the aggregate value of this agreement shall not exceed the dollar limitation set forth in Section 2271.002(a)(2) of the Texas Government Code, as amended, or Section 2274.002(a)(2) of the Texas Government Code, as amended.

In addition, the Issuer agrees to reimburse the Bank upon its request for all reasonable expenses, disbursements and advances incurred or made by the Bank in accordance with any of

the provisions hereof (including the reasonable compensation and the expenses and disbursements of its agents and counsel).

## **ARTICLE TWO DEFINITIONS**

**Section 2.01 Definitions.** For all purposes of this Agreement, except as otherwise expressly provided or unless the context otherwise requires:

“Acceleration Date” on any Security means the date, if any, on and after which the principal or any or all installments of interest, or both, are due and payable on any Security which has become accelerated pursuant to the terms of the Security.

“Authorizing Document” means the resolution, order, or ordinance of the governing body of the Issuer pursuant to which the Securities are issued, as the same may be amended or modified, including any pricing certificate related thereto, certified by the secretary or any other officer of the Issuer and delivered to the Bank.

“Bank Office” means the designated office of the Bank at the address shown in Section 3.01 hereof. The Bank will notify the Issuer in writing of any change in location of the Bank Office.

“Holder” and “Security Holder” each means the Person in whose name a Security is registered in the Security Register.

“Person” means any individual, corporation, partnership, joint venture, association, joint stock company, trust, unincorporated organization or government or any agency or political subdivision of a government.

“Predecessor Securities” of any particular Security means every previous Security evidencing all or a portion of the same obligation as that evidenced by such particular Security (and, for the purposes of this definition, any mutilated, lost, destroyed, or stolen Security for which a replacement Security has been registered and delivered in lieu thereof pursuant to Section 4.06 hereof and the Authorizing Document).

“Redemption Date”, when used with respect to any Security to be redeemed, means the date fixed for such redemption pursuant to the terms of the Authorizing Document.

“Responsible Officer”, when used with respect to the Bank, means the Chairman or Vice-Chairman of the Board of Directors, the Chairman or Vice-Chairman of the Executive Committee of the Board of Directors, the President, any Vice President, the Secretary, any Assistant Secretary, the Treasurer, any Assistant Treasurer, the Cashier, any Assistant Cashier, any Trust Officer or Assistant Trust Officer, or any other officer of the Bank customarily performing functions similar to those performed by any of the above designated officers and also means, with respect to a particular corporate trust matter, any



other officer to whom such matter is referred because of his knowledge of and familiarity with the particular subject.

“Security Register” means a register maintained by the Bank on behalf of the Issuer providing for the registration and transfers of Securities.

“Stated Maturity” means the date specified in the Authorizing Document the principal of a Security is scheduled to be due and payable.

**Section 2.02 Other Definitions.** The terms “Bank,” “Issuer,” and “Securities (Security)” have the meanings assigned to them in the recital paragraphs of this Agreement.

The term “Paying Agent/Registrar” refers to the Bank in the performance of the duties and functions of this Agreement.

### ARTICLE THREE PAYING AGENT

**Section 3.01 Duties of Paying Agent.** As Paying Agent, the Bank shall pay, provided adequate collected funds have been provided to it for such purpose by or on behalf of the Issuer, on behalf of the Issuer the principal of each Security at its Stated Maturity, Redemption Date or Acceleration Date, to the Holder upon surrender of the Security to the Bank at the following address:

By Registered or Certified Mail

\_\_\_\_\_  
\_\_\_\_\_  
\_\_\_\_\_

By Hand or Overnight Mail

\_\_\_\_\_  
\_\_\_\_\_  
\_\_\_\_\_

As Paying Agent, the Bank shall, provided adequate collected funds have been provided to it for such purpose by or on behalf of the Issuer, pay on behalf of the Issuer the interest on each Security when due, by computing the amount of interest to be paid each Holder and making payment thereof to the Holders of the Securities (or their Predecessor Securities) on the Record Date (as defined in the Authorizing Document). All payments of principal and/or interest on the Securities to the registered owners shall be accomplished (1) by the issuance of checks, payable to the registered owners, drawn on the paying agent account provided in Section 5.05 hereof, sent by United States mail, first class postage prepaid, to the address appearing on the Security Register or (2) by such other method, acceptable to the Bank, requested in writing by the Holder at the Holder’s risk and expense.

**Section 3.02 Payment Dates.** The Issuer hereby instructs the Bank to pay the principal of and interest on the Securities on the dates specified in the Authorizing Document.

### ARTICLE FOUR REGISTRAR

**Section 4.01 Security Register - Transfers and Exchanges.** The Bank agrees to keep and maintain for and on behalf of the Issuer at the Bank Office books and records (herein sometimes referred to as the “Security Register”) for recording the names and addresses of the Holders of the Securities, the transfer, exchange and replacement of the Securities and the payment of the principal of and interest on the Securities to the Holders and containing such other

information as may be reasonably required by the Issuer and subject to such reasonable regulations as the Issuer and the Bank may prescribe. All transfers, exchanges and replacements of Securities shall be noted in the Security Register.

Every Security surrendered for transfer or exchange shall be duly endorsed or be accompanied by a written instrument of transfer, the signature on which has been guaranteed by an officer of a federal or state bank or a member of the Financial Industry Regulatory Authority, such written instrument to be in a form satisfactory to the Bank and duly executed by the Holder thereof or his agent duly authorized in writing.

The Bank may request any supporting documentation it feels necessary to effect a re-registration, transfer or exchange of the Securities.

To the extent possible and under reasonable circumstances, the Bank agrees that, in relation to an exchange or transfer of Securities, the exchange or transfer by the Holders thereof will be completed and new Securities delivered to the Holder or the assignee of the Holder in not more than three (3) business days after the receipt of the Securities to be cancelled in an exchange or transfer and the written instrument of transfer or request for exchange duly executed by the Holder, or his duly authorized agent, in form and manner satisfactory to the Paying Agent/Registrar.

**Section 4.02 Securities.** The Issuer shall provide additional Securities when needed to facilitate transfers or exchanges thereof. The Bank covenants that such additional Securities, if and when provided, will be kept in safekeeping pending their use and reasonable care will be exercised by the Bank in maintaining such Securities in safekeeping, which shall be not less than the care maintained by the Bank for debt securities of other governments or corporations for which it serves as registrar, or that is maintained for its own securities.

**Section 4.03 Form of Security Register.** The Bank, as Registrar, will maintain the Security Register relating to the registration, payment, transfer and exchange of the Securities in accordance with the Bank's general practices and procedures in effect from time to time. The Bank shall not be obligated to maintain such Security Register in any form other than those which the Bank has currently available and currently utilizes at the time.

The Security Register may be maintained in written form or in any other form capable of being converted into written form within a reasonable time.

**Section 4.04 List of Security Holders.** The Bank will provide the Issuer at any time requested by the Issuer, upon payment of the required fee, a copy of the information contained in the Security Register. The Issuer may also inspect the information contained in the Security Register at any time the Bank is customarily open for business, provided that reasonable time is allowed the Bank to provide an up-to-date listing or to convert the information into written form.

The Bank will not release or disclose the contents of the Security Register to any person other than to, or at the written request of, an authorized officer or employee of the Issuer, except upon receipt of a court order or as otherwise required by law. Upon receipt of a court order and prior to the release or disclosure of the contents of the Security Register, the Bank will notify the Issuer so that the Issuer may contest the court order or such release or disclosure of the contents of the Security Register.

**Section 4.05 Return of Cancelled Securities.** The Bank will, at such reasonable intervals as it determines, surrender to the Issuer, all Securities in lieu of which or in exchange for which other Securities have been issued, or which have been paid.

**Section 4.06 Mutilated, Destroyed, Lost or Stolen Securities.** The Issuer hereby instructs the Bank, subject to the provisions of the Authorizing Document, to deliver and issue Securities in exchange for or in lieu of mutilated, destroyed, lost, or stolen Securities as long as the same does not result in an overissuance.

In case any Security shall be mutilated, destroyed, lost or stolen, the Bank may execute and deliver a replacement Security of like form and tenor, and in the same denomination and bearing a number not contemporaneously outstanding, in exchange and substitution for such mutilated Security, or in lieu of and in substitution for such mutilated, destroyed, lost or stolen Security, only upon the approval of the Issuer and after (i) the filing by the Holder thereof with the Bank of evidence satisfactory to the Bank of the destruction, loss or theft of such Security, and of the authenticity of the ownership thereof and (ii) the furnishing to the Bank of indemnification in an amount satisfactory to hold the Issuer and the Bank harmless. All expenses and charges associated with such indemnity and with the preparation, execution and delivery of a replacement Security shall be borne by the Holder of the Security mutilated, destroyed, lost or stolen.

**Section 4.07 Transaction Information to Issuer.** The Bank will, within a reasonable time after receipt of written request from the Issuer, furnish the Issuer information as to the Securities it has paid pursuant to Section 3.01, Securities it has delivered upon the transfer or exchange of any Securities pursuant to Section 4.01, and Securities it has delivered in exchange for or in lieu of mutilated, destroyed, lost, or stolen Securities pursuant to Section 4.06.

## **ARTICLE FIVE THE BANK**

**Section 5.01 Duties of Bank.** The Bank undertakes to perform the duties set forth herein and agrees to use reasonable care in the performance thereof.

**Section 5.02 Reliance on Documents, Etc.**

(a) The Bank may conclusively rely, as to the truth of the statements and correctness of the opinions expressed therein, on certificates or opinions furnished to the Bank.

(b) The Bank shall not be liable for any error of judgment made in good faith by a Responsible Officer, unless it shall be proved that the Bank was negligent in ascertaining the pertinent facts.

(c) No provisions of this Agreement shall require the Bank to expend or risk its own funds or otherwise incur any financial liability for performance of any of its duties hereunder, or in the exercise of any of its rights or powers, if it shall have reasonable grounds for believing that repayment of such funds or adequate indemnity satisfactory to it against such risks or liability is not assured to it.

(d) The Bank may rely and shall be protected in acting or refraining from acting upon any resolution, certificate, statement, instrument, opinion, report, notice, request, direction, consent, order, bond, note, security or other paper or document believed by it to be genuine and to have been signed or presented by the proper party or parties. Without limiting the generality

of the foregoing statement, the Bank need not examine the ownership of any Securities, but is protected in acting upon receipt of Securities containing an endorsement or instruction of transfer or power of transfer which appears on its face to be signed by the Holder or an agent of the Holder. The Bank shall not be bound to make any investigation into the facts or matters stated in a resolution, certificate, statement, instrument, opinion, report, notice, request, direction, consent, order, bond, note, security or other paper or document supplied by the Issuer.

(e) The Bank may consult with counsel, and the written advice of such counsel or any opinion of counsel shall be full and complete authorization and protection with respect to any action taken, suffered, or omitted by it hereunder in good faith and in reliance thereon.

(f) The Bank may exercise any of the powers hereunder and perform any duties hereunder either directly or by or through agents or attorneys of the Bank.

(g) The Bank is also authorized to transfer funds relating to the closing and initial delivery of the Securities in the manner disclosed in the closing memorandum or letter as prepared by the Issuer, Issuer's financial advisor or other agent. The Bank may act on a facsimile or e-mail transmission of the closing memorandum or letter acknowledged by the Issuer, the Issuer's financial advisor or other agent as the final closing memorandum or letter. The Bank shall not be liable for any losses, costs or expenses arising directly or indirectly from the Bank's reliance upon and compliance with such instructions.

**Section 5.03 Recitals of Issuer.** The recitals contained herein with respect to the Issuer and in the Securities shall be taken as the statements of the Issuer, and the Bank assumes no responsibility for their correctness.

The Bank shall in no event be liable to the Issuer, any Holder or Holders of any Security, or any other Person for any amount due on any Security from its own funds.

**Section 5.04 May Hold Securities.** The Bank, in its individual or any other capacity, may become the owner or pledgee of Securities and may otherwise deal with the Issuer with the same rights it would have if it were not the Paying Agent/Registrar, or any other agent.

**Section 5.05 Moneys Held by Bank - Paying Agent Account/Collateralization.** A paying agent account shall at all times be kept and maintained by the Bank for the receipt, safekeeping, and disbursement of moneys received from the Issuer under this Agreement for the payment of the Securities, and money deposited to the credit of such account until paid to the Holders of the Securities shall be continuously collateralized by securities or obligations which qualify and are eligible under both the laws of the State of Texas and the laws of the United States of America to secure and be pledged as collateral for paying agent accounts to the extent such money is not insured by the Federal Deposit Insurance Corporation. Payments made from such paying agent account shall be made by check drawn on such account unless the owner of the Securities shall, at its own expense and risk, request an alternative method of payment.

Subject to the applicable unclaimed property laws of the State of Texas, any money deposited with the Bank for the payment of the principal of, premium (if any), or interest on any Security and remaining unclaimed for three years after final maturity of the Security has become due and payable will be held by the Bank and disposed of only in accordance with Title 6 of the Texas Property Code, as amended. The Bank shall have no liability by virtue of actions taken in compliance with this provision.

The Bank is not obligated to pay interest on any money received by it under this Agreement.

This Agreement relates solely to money deposited for the purposes described herein, and the parties agree that the Bank may serve as depository for other funds of the Issuer, act as trustee under indentures authorizing other bond transactions of the Issuer, or act in any other capacity not in conflict with its duties hereunder.

**Section 5.06 Indemnification.** To the extent permitted by law, the Issuer agrees to indemnify the Bank for, and hold it harmless against, any loss, liability, or expense incurred without negligence or bad faith on its part, arising out of or in connection with its acceptance or administration of its duties hereunder, including the cost and expense against any claim or liability in connection with the exercise or performance of any of its powers or duties under this Agreement.

**Section 5.07 Interpleader.** The Issuer and the Bank agree that the Bank may seek adjudication of any adverse claim, demand, or controversy over its person as well as funds on deposit, in either a Federal or State District Court located in the state and county where the administrative office of the Issuer is located, and agree that service of process by certified or registered mail, return receipt requested, to the address referred to in Section 6.03 of this Agreement shall constitute adequate service. The Issuer and the Bank further agree that the Bank has the right to file a Bill of Interpleader in any court of competent jurisdiction in the State of Texas to determine the rights of any Person claiming any interest herein.

**Section 5.08 DTC Services.** It is hereby represented and warranted that, in the event the Securities are otherwise qualified and accepted for “Depository Trust Company” services or equivalent depository trust services by other organizations, the Bank has the capability and, to the extent within its control, will comply with the “Operational Arrangements”, which establishes requirements for securities to be eligible for such type depository trust services, including, but not limited to, requirements for the timeliness of payments and funds availability, transfer turnaround time, and notification of redemptions and calls.

## **ARTICLE SIX MISCELLANEOUS PROVISIONS**

**Section 6.01 Amendment.** This Agreement may be amended only by an agreement in writing signed by both of the parties hereto.

**Section 6.02 Assignment.** This Agreement may not be assigned by either party without the prior written consent of the other.

**Section 6.03 Notices.** Any request, demand, authorization, direction, notice, consent, waiver, or other document provided or permitted hereby to be given or furnished to the Issuer or the Bank shall be mailed or delivered to the Issuer or the Bank, respectively, at the addresses shown on the signature page hereof.

**Section 6.04 Effect of Headings.** The Article and Section headings herein are for convenience of reference only and shall not affect the construction hereof.

**Section 6.05 Successors and Assigns.** All covenants and agreements herein by the Issuer shall bind its successors and assigns, whether so expressed or not.

**Section 6.06 Severability.** In case any provision herein shall be invalid, illegal, or unenforceable, the validity, legality, and enforceability of the remaining provisions shall not in any way be affected or impaired thereby.

**Section 6.07 Merger, Conversion, Consolidation, or Succession.** Any corporation or association into which the Bank may be merged or converted or with which it may be consolidated, or any corporation or association resulting from any merger, conversion, or consolidation to which the Bank shall be a party, or any corporation or association succeeding to all or substantially all of the corporate trust business of the Bank shall be the successor of the Bank as Paying Agent under this Agreement without the execution or filing of any paper or any further act on the part of either parties hereto.

**Section 6.08 Benefits of Agreement.** Nothing herein, express or implied, shall give to any Person, other than the parties hereto and their successors hereunder, any benefit or any legal or equitable right, remedy, or claim hereunder.

**Section 6.09 Entire Agreement.** This Agreement and the Authorizing Document constitute the entire agreement between the parties hereto relative to the Bank acting as Paying Agent/Registrar and if any conflict exists between this Agreement and the Authorizing Document, the Authorizing Document shall govern.

**Section 6.10 Counterparts.** This Agreement may be executed in any number of counterparts, each of which shall be deemed an original and all of which shall constitute one and the same Agreement.

**Section 6.11 Termination.** This Agreement will terminate (i) on the date of final payment of the principal of and interest on the Securities to the Holders thereof or (ii) may be earlier terminated by either party upon sixty (60) days written notice; provided, however, an early termination of this Agreement by either party shall not be effective until (a) a successor Paying Agent/Registrar has been appointed by the Issuer and such appointment accepted and (b) notice has been given to the Holders of the Securities of the appointment of a successor Paying Agent/Registrar. However, if the Issuer fails to appoint a successor Paying Agent/Registrar within a reasonable time, the Bank may petition a court of competent jurisdiction within the State of Texas to appoint a successor. Furthermore, the Bank and the Issuer mutually agree that the effective date of an early termination of this Agreement shall not occur at any time which would disrupt, delay or otherwise adversely affect the payment of the Securities.

Upon an early termination of this Agreement, the Bank agrees to promptly transfer and deliver the Security Register (or a copy thereof), together with the other pertinent books and records relating to the Securities, to the successor Paying Agent/Registrar designated and appointed by the Issuer.

The provisions of Section 1.02 and of Article Five shall survive and remain in full force and effect following the termination of this Agreement.

**Section 6.12 Iran, Sudan or Foreign Terrorist Organizations.** The Bank represents that neither it nor any of its parent company, wholly- or majority-owned subsidiaries, and other affiliates is a company identified on a list prepared and maintained by the Texas Comptroller of Public Accounts under Section 2252.153 or Section 2270.0201, Texas Government Code, and posted on any of the following pages of such officer's internet website:

<https://comptroller.texas.gov/purchasing/docs/sudan-list.pdf>,  
<https://comptroller.texas.gov/purchasing/docs/iran-list.pdf>, or  
<https://comptroller.texas.gov/purchasing/docs/fto-list.pdf>.

The foregoing representation is made solely to comply with Section 2252.152, Texas Government Code, and to the extent such Section does not contravene applicable Federal law and excludes the Bank and each of its parent company, wholly- or majority-owned subsidiaries, and other affiliates, if any, that the United States government has affirmatively declared to be excluded from its federal sanctions regime relating to Sudan or Iran or any federal sanctions regime relating to a foreign terrorist organization. The Bank understands “affiliate” to mean any entity that controls, is controlled by, or is under common control with the Bank and exists to make a profit.

**Section 6.13 Governing Law.** This Agreement shall be construed in accordance with and governed by the laws of the State of Texas.

*[Remainder of page left blank intentionally.]*

IN WITNESS WHEREOF, the parties hereto have executed this Agreement as of the day and year first above written.

\_\_\_\_\_

By: \_\_\_\_\_

Title: \_\_\_\_\_

Attest:

Address: \_\_\_\_\_

\_\_\_\_\_

\_\_\_\_\_

\_\_\_\_\_

\_\_\_\_\_

Title: \_\_\_\_\_



CITY OF EL PASO, TEXAS

By: \_\_\_\_\_  
Pricing Officer

Address: El Paso Water Utilities  
1154 Hawkins Blvd.  
El Paso, Texas 79925

## ANNEX A

**EXHIBIT B**

(a) Form of Bond.

REGISTERED  
No. \_\_\_\_\_

REGISTERED  
\$ \_\_\_\_\_

UNITED STATES OF AMERICA  
STATE OF TEXAS  
COUNTY OF EL PASO  
CITY OF EL PASO, TEXAS,  
MUNICIPAL DRAINAGE UTILITY SYSTEM  
REVENUE REFUNDING BONDS, SERIES 2023

INTEREST RATE:      MATURITY DATE:      INITIAL DATE:      CUSIP NO.:  
\_\_\_\_\_ %      March 1, 20\_\_      \_\_\_\_\_, 20\_\_      \_\_\_\_\_

The City of El Paso (the "City"), in the County of El Paso, State of Texas, for value received, hereby promises to pay to

\_\_\_\_\_

or registered assigns, but solely from the sources and in the manner hereinafter provided, on the Maturity Date specified above, the sum of

\_\_\_\_\_ DOLLARS

unless this Bond shall have been sooner called for prior redemption and the payment of the principal hereof shall have been paid or provided for, and to pay interest on such principal amount from the later of the date of delivery or the most recent interest payment date to which interest has been paid or provided for until payment of such principal amount has been paid or provided for, at the per annum rate of interest specified above, computed on the basis of a 360-day year of twelve 30-day months, such interest to be paid semiannually on March 1 and September 1 of each year, commencing \_\_\_\_\_ 1, 20\_\_\_. The principal of this Bond shall be payable without exchange or collection charges in lawful money of the United States of America upon presentation and surrender of this Bond at the designated payment/transfer office in Minneapolis, Minnesota (the "Designated Payment/Transfer Office") of Computershare Trust Company, N.A., Paying Agent/Registrar, or at the Designated Payment/Transfer Office of any successor thereto. Interest on this Bond is payable by check, dated as of the interest payment date, mailed by the Paying Agent/Registrar to the registered owner at the address shown on the registration books kept by the Paying Agent/Registrar or by such other customary banking arrangements acceptable to the Paying Agent/Registrar and the person to whom interest is paid; provided, however, that such person shall bear all risk and expense of such other customary banking arrangements. For the purpose of the payment of interest on this Bond, the registered owner shall be the person in whose name this Bond is registered at the close of business on the "Record Date," which shall be the fifteenth day of the month next preceding such interest payment date. In the event of a nonpayment of interest on a scheduled payment date, and for thirty days thereafter, a new record date for such interest payment (a "Special Record Date") will be established by the Paying Agent/Registrar, if and when funds

for the payment of such interest have been received from the City. Notice of the Special Record Date and of the scheduled payment date of the past due interest (which date shall be fifteen days after the Special Record Date) shall be sent at least five business days prior to the Special Record Date by United States mail, first class, postage prepaid, to the address of each owner of a Bond appearing on the books of the Paying Agent/Registrar at the close of business on the last business day next preceding the date of mailing of such notice.

If the date for the payment of the principal of or interest on this Bond shall be a Saturday, Sunday, legal holiday, or day on which banking institutions in the city where the Designated Payment/Transfer Office is located are required or authorized by law or executive order to close, the date for such payment shall be the next succeeding day which is not a Saturday, Sunday, legal holiday, or day on which banking institutions are required or authorized to close, and payment on such date shall for all purposes be deemed to have been made on the original date payment was due.

This Bond is one of a series of fully registered bonds specified in the title hereof, dated as of \_\_\_\_\_, 20\_\_, issued in the aggregate principal amount of \$\_\_\_\_\_ (herein referred to as the "Bonds"), and issued pursuant to the authority provided by Texas Government Code, Chapters 1207 and 1371, as amended, and a certain ordinance of the City (the "Ordinance"), for the purposes of (i) refunding the Refunded Revolving Notes and (ii) paying the costs of issuing the Bonds as described in the Ordinance. Capitalized terms used herein and not otherwise defined shall have the meaning assigned thereto in the Ordinance.

The Bonds are special obligations of the City, payable solely from and, together with the Previously Issued Bonds (identified and defined in the Ordinance), equally and ratably secured by a first lien on and pledge of the Net Revenues (as defined in the Ordinance) of the City's Municipal Drainage Utility System (as defined in the Ordinance and hereinafter referred to as the "System"). The Bonds do not constitute a legal or equitable pledge, charge, lien or encumbrance upon any property of the City or the System, except with respect to the Net Revenues. The Owner hereof shall never have the right to demand payment of this obligation out of any funds raised or to be raised by taxation.

Subject to satisfying the terms and conditions prescribed therefor, the City has reserved the right to issue additional revenue obligations payable from and equally and ratably secured by a parity lien on and pledge of the Net Revenues of the System, in the same manner and to the same extent as the Bonds.

The City reserves the option to redeem Bonds maturing on or after March 1, 20\_\_\_, in whole or in part, in principal amounts of \$5,000 or any integral multiple thereof, before their respective scheduled maturity dates, on \_\_\_\_\_, 20\_\_ or on any date thereafter, at a price equal to the principal amount of the Bonds so called for redemption plus accrued interest to the redemption date. If less than all of the Bonds are to be redeemed, the City shall determine the maturity or maturities and the amounts thereof to be redeemed and shall direct the Paying Agent/Registrar to call by lot the Bonds, or portions thereof, within such maturity and in such principal amounts, for redemption.

A portion of a single Bond of a denomination greater than \$5,000 may be redeemed, but only in a principal amount equal to \$5,000 or any integral multiple thereof. If such a Bond is to be partially redeemed, the Paying Agent/Registrar shall assign a separate number for each \$5,000 portion of the Bonds and select the portion or portions of the Bond to be redeemed by lot or by any other customary method that results in a random selection.

[The Bonds stated to mature on March 1, 20\_\_ and March 1, 20\_\_ (the “Term Bonds”) are subject to scheduled mandatory redemption and will be redeemed by the City, in part at a price equal to the principal amount thereof, without premium, plus accrued interest to the redemption date, out of moneys available for such purpose in the Interest and Sinking Fund, on the dates and in the respective principal amounts as set forth in the following schedule:

Term Bonds Maturing March 1, 20__	
<u>Redemption Date</u>	<u>Principal Amount</u>
March 1, 20__	\$ ,000
March 1, 20__ (maturity)	\$ ,000

Term Bonds Maturing March 1, 20__	
<u>Redemption Date</u>	<u>Principal Amount</u>
March 1, 20__	\$ ,000
March 1, 20__	\$ ,000
March 1, 20__	\$ ,000
March 1, 20__ (maturity)	\$ ,000

The Paying Agent/Registrar will select by lot or by any other customary method that results in a random selection the specific Term Bonds (or with respect to Term Bonds having a denomination in excess of \$5,000, each \$5,000 portion thereof) to be redeemed by mandatory redemption. The principal amount of Term Bonds required to be redeemed on any redemption date pursuant to the foregoing mandatory sinking fund redemption provisions hereof shall be reduced, at the option of the City, by the principal amount of any Term Bonds which, at least 45 days prior to the mandatory sinking fund redemption date (i) shall have been acquired by the City at a price not exceeding the principal amount of such Term Bonds plus accrued interest to the date of purchase thereof, and delivered to the Paying Agent/Registrar for cancellation, or (ii) shall have been redeemed pursuant to the optional redemption provisions hereof and not previously credited to a mandatory sinking fund redemption.]

Notice of such redemption or redemptions shall be given by United States mail, first-class, postage prepaid, not less than 30 days before the date fixed for redemption, to the registered owner of each of the Bonds to be redeemed in whole or in part. Notice having been so given, the Bonds or portions thereof designated for redemption shall become due and payable on the redemption date specified in such notice, and from and after such date, notwithstanding that any of the Bonds or portions thereof so called for redemption shall not have been surrendered for payment, interest on such Bonds or portions thereof shall cease to accrue.

As provided in the Ordinance and subject to certain limitations therein set forth, this Bond is transferable upon surrender of this Bond for transfer at the Designated Payment/Transfer Office of the Paying Agent/Registrar with such endorsement or other evidence of transfer as is acceptable

to the Paying Agent/Registrar, and, thereupon, one or more new fully registered Bonds of the same stated maturity, of authorized denominations, bearing the same rate of interest, and for the same aggregate principal amount will be issued to the designated transferee or transferees.

Neither the City nor the Paying Agent/Registrar shall be required to issue, transfer or exchange any Bond called for redemption when such redemption is to occur within 45 calendar days after the transfer or exchange date. However, such limitations of transfer shall not be applicable to an exchange by the Owner of the unredeemed balance of a Bond called for redemption in part.

With respect to any optional redemption of the Bonds, unless certain prerequisites to such redemption required by the Ordinance have been met and moneys sufficient to pay the principal of and premium, if any, and interest on the Bonds to be redeemed shall have been received by the Paying Agent/Registrar prior to the giving of such notice of redemption, such notice shall state that such redemption may, at the option of the City, be conditional upon the satisfaction of such prerequisites and receipt of such moneys by the Paying Agent/Registrar on or prior to the date fixed for such redemption, or upon any prerequisite set forth in such notice of redemption. If a conditional notice of redemption is given and such prerequisites to the redemption and sufficient moneys are not received, such notice shall be of no force and effect, the City shall not redeem such Bonds and the Paying Agent/Registrar shall give notice, in the manner in which the notice of redemption was given, to the effect that the Bonds have not been redeemed.

The City, the Paying Agent/Registrar, and any other person may treat the person in whose name this Bond is registered as the owner hereof for the purpose of receiving payment as herein provided (except interest shall be paid to the person in whose name this Bond is registered on the Record Date) and for all other purposes, whether or not this Bond be overdue, and neither the City, the Paying Agent/Registrar, nor any such agent shall be affected by notice to the contrary.

IT IS HEREBY CERTIFIED AND RECITED that this Bond has been duly and validly issued and delivered; that all acts, conditions, and things required or proper to be performed, exist, and be done precedent to or in the issuance and delivery of this Bond have been performed, existed, and been done in accordance with law; and that the interest on and principal of this Bond and the series of which it is a part, together with the Previously Issued Bonds, are secured by and payable from an irrevocable first lien on and pledge of the Net Revenues of the System, as provided in Ordinance, and not from any other revenues, funds or assets of the City.

This Bond shall not be deemed to constitute a debt of the City or a pledge of its faith and credit; nor shall the Owners hereof ever have the right to demand payment of this Bond out of any funds raised or to be raised by taxation.

IN WITNESS WHEREOF, the City has caused this Bond to be executed in its name by the manual or facsimile signature of the Mayor of the City and countersigned by the manual or facsimile signature of the City Clerk or Alternate City Clerk, and the official seal of the City has been duly impressed or placed in facsimile on this Bond.

\_\_\_\_\_  
City Clerk  
City of El Paso, Texas

\_\_\_\_\_  
Mayor  
City of El Paso, Texas

(SEAL)

(b) Form of Comptroller’s Registration Certificate.

[to be printed on Initial Bond only]

OFFICE OF THE COMPTROLLER §  
OF PUBLIC ACCOUNTS § REGISTER NO. \_\_\_\_\_  
OF THE STATE OF TEXAS §

I hereby certify that there is on file and of record in my office a certificate of the Attorney General of the State of Texas to the effect that this Bond has been examined by him as required by law, that he finds that it has been issued in conformity with the Constitution and laws of the State of Texas, and that it is a valid and binding special obligation of the City of El Paso, Texas, payable from the revenues pledged to its payment by and in the ordinance authorizing same and that such Bond has this day been registered by me.

Witness my hand and seal of office at Austin, Texas, on this date: \_\_\_\_\_.

\_\_\_\_\_  
Comptroller of Public Accounts  
of the State of Texas

(SEAL)

(c) Form of Certificate of Paying Agent/Registrar.

CERTIFICATE OF PAYING AGENT/REGISTRAR

This Bond has been duly issued and registered under the provisions of the within-mentioned Ordinance; the bond or bonds of the above entitled and designated series originally delivered having been approved by the Attorney General of the State of Texas and registered by the Comptroller of Public Accounts, as shown by the records of the Paying Agent/Registrar.

The designated office of the Paying Agent/Registrar in Minneapolis, Minnesota, is the Designated Payment/Transfer Office for this Bond.

COMPUTERSHARE TRUST COMPANY,  
N.A., as Paying Agent/Registrar

Dated: \_\_\_\_\_

By: \_\_\_\_\_

Authorized Signature

(d) Form of Assignment.

ASSIGNMENT

FOR VALUE RECEIVED, the undersigned hereby sells, assigns, and transfers unto (print or typewrite name, address and Zip Code of transferee):  
\_\_\_\_\_  
\_\_\_\_\_

(Social Security or other identifying number: \_\_\_\_\_) the within Bond and all rights hereunder and hereby irrevocably constitutes and appoints \_\_\_\_\_ attorney to transfer the within Bond on the books kept for registration hereof, with full power of substitution in the premises.

Dated: \_\_\_\_\_

Signature Guaranteed By:

NOTICE: The signature on this Assignment must correspond with the name of the registered owner as it appears on the face of the within Bond in every particular and must be guaranteed in a manner acceptable to the Paying Agent/Registrar.

\_\_\_\_\_  
Authorized Signatory

(e) The Initial Bond shall be in the form set forth in subsection (a) of this Exhibit, except for the following alterations:

(i) Immediately under the name of the Bond, the headings "Interest Rate" and "Maturity Date" shall be completed with the words "As Shown Below," and the heading "CUSIP No." shall be deleted.



(ii) in the first paragraph of the Bond the words “on the Maturity Date specified above, the sum of \_\_\_\_\_ DOLLARS” shall be deleted and the following will be inserted: “on March 1 in each of the years, in the principal amounts and bearing interest at the per annum rates set forth in the following schedule:

<u>Year</u>	<u>Principal Amount</u>	<u>Interest Rate</u>
-------------	-------------------------	----------------------

(Information to be inserted from the Pricing Certificate)

(iii) the Initial Bond shall be numbered T-1.

(f) The Comptroller’s Registration Certificate may be deleted from the definitive Bonds if such Certificate on the Initial Bond is fully executed.

(g) The Certificate of the Paying Agent/Registrar may be deleted from the Initial Bond if the Comptroller’s Registration Certificate appears thereon.



---

File #: 22-754, Version: 1

---

**CITY OF EL PASO, TEXAS  
LEGISTAR AGENDA ITEM SUMMARY FORM**

**DISTRICT, DEPARTMENT, CONTACT INFORMATION:**

*Please choose District and Department from drop down menu. Please post exactly as example below.  
No Title's, No emails. Please use ARIAL 10 Font.*

**District 1**

Planning and Inspections, Philip F. Etiwe, (915) 212-1553  
Planning and Inspections, Andrew Salloum, (915) 212-1603

**AGENDA LANGUAGE:**

*This is the language that will be posted to the agenda. Please use ARIAL 11 Font.*

An Ordinance changing the zoning of a portion of Tract 9A1, 9B1, Laura E. Mundy Survey 238 and a portion of Nellie D. Mundy Survey No. 244, City of El Paso, El Paso County, Texas from R-5/c (Residential/conditions) to C-2/c (Commercial/conditions) and from R-5/sp (Residential/special permit) to C-2 (Commercial) and imposing conditions. The penalty is as provided for in Chapter 20.24 of the El Paso City Code.

The proposed rezoning meets the intent of the Future Land Use designation for the property and is in accordance with Plan El Paso, the City's Comprehensive Plan.

Subject Property: Generally North of Transmountain Road and East of Interstate 10  
Applicant: EP Transmountain Residential, LLC. PZRZ22-00009  
[POSTPONED FROM 07-19-2022]

**CITY OF EL PASO, TEXAS  
AGENDA ITEM  
DEPARTMENT HEAD'S SUMMARY FORM**

**AGENDA DATE:** June 22, 2022

**PUBLIC HEARING DATE:** July 19, 2022

**CONTACT PERSON(S) NAME AND PHONE NUMBER:** Philip F. Etiwe, (915) 212-1553  
Andrew Salloum, (915) 212-1603

**DISTRICT(S) AFFECTED:** District 1

**STRATEGIC GOAL:** #3 Promote the Visual Image of El Paso

**SUBGOAL:** 3.2 Set one standard for infrastructure across the city

**SUBJECT:**

An Ordinance changing the zoning of a portion of Tract 9A1, 9B1, Laura E. Mundy Survey 238 and a portion of Nellie D. Mundy Survey No. 244, City of El Paso, El Paso County, Texas from R-5/c (Residential/conditions) to C-2/c (Commercial/conditions) and from R-5/sp (Residential/special permit) to C-2 (Commercial) and imposing conditions. The penalty is as provided for in Chapter 20.24 of the El Paso City Code.

The proposed rezoning meets the intent of the Future Land Use designation for the property and is in accordance with *Plan El Paso*, the City's Comprehensive Plan.

Subject Property: Generally North of Transmountain Road and East of Interstate 10

Applicant: EP Transmountain Residential, LLC. PZRZ22-00009

**BACKGROUND / DISCUSSION:**

The applicant is requesting to rezone from R-5/c (Residential/conditions) to C-2/c (Commercial/conditions) and R-5/sp (Residential/special permit) to C-2 (Commercial) to allow for commercial development. City Plan Commission recommended 7-0 to approve the proposed rezoning with three conditions on May 5, 2022. As of June 13, 2022, the Planning Division did not receive any communications in support or opposition to the request from the public. See attached staff report for additional information.

**PRIOR COUNCIL ACTION:**

N/A

**AMOUNT AND SOURCE OF FUNDING:**

N/A

**HAVE ALL AFFECTED DEPARTMENTS BEEN NOTIFIED?**  YES  NO

**PRIMARY DEPARTMENT:** Planning & Inspections, Planning Division

**SECONDARY DEPARTMENT:** N/A

---

\*\*\*\*\*REQUIRED AUTHORIZATION\*\*\*\*\*

**DEPARTMENT HEAD:**

---

*Philip Etiwe*

ORDINANCE NO. \_\_\_\_\_

**AN ORDINANCE CHANGING THE ZONING OF A PORTION OF TRACT 9A1, 9B1, LAURA E. MUNDY SURVEY 238 AND A PORTION OF NELLIE D. MUNDY SURVEY NO. 244, CITY OF EL PASO, EL PASO COUNTY, TEXAS FROM R-5/C (RESIDENTIAL/CONDITIONS) TO C-2/C (COMMERCIAL/CONDITIONS) AND FROM R-5/SP (RESIDENTIAL/SPECIAL PERMIT) TO C-2 (COMMERCIAL) AND IMPOSING CONDITIONS. THE PENALTY IS AS PROVIDED FOR IN CHAPTER 20.24 OF THE EL PASO CITY CODE.**

**NOW THEREFORE, BE IT ORDAINED BY THE CITY COUNCIL OF THE CITY OF EL PASO:**

Pursuant to Section 20.04.360 of the El Paso City Code, that the zoning of A portion of Tract 9A1, 9B1, Laura E. Mundy Survey 238 and a portion of Nellie D. Mundy Survey No. 244, *located in the City of El Paso, El Paso County, Texas*, and as more particularly described by metes and bounds on the attached Exhibit "A", incorporated by reference, be changed from **R-5/c (Residential/conditions)** to **C-2/c (Commercial/conditions)** and **R-5/sp (Residential/special permit)** to **C-2 (Commercial)**, as defined in Section 20.06.020, and that the zoning map of the City of El Paso be revised accordingly, and that the special permit designation be rescinded

Further, that the property described above be subject to the following conditions which are necessitated by and attributable to the change in intensity generated by the change of zoning in order to protect the health, safety and welfare of the adjacent property owners and the residents of this City:

1. That a ten-foot (10') landscaped buffer with high-profile native or naturalized trees of at least two-inch (2") caliper and ten feet (10') in height shall be placed at twenty feet (20') on center along the property lines adjacent to residential zone districts or uses. The landscaped buffer shall be irrigated and maintained by the property owner at all times and shall be installed prior to the issuance of any certificates of occupancy.
  - a. This condition shall not apply where the existing arroyo will serve as a natural buffer between the subject properties and residential zone districts or uses.
  - b. The landscaping required under this condition will count towards the landscaping required under Title 18.
2. That a detailed site development plan shall be reviewed and approved per the El Paso City Code prior to the issuance of building permits.
3. That a minimum 500-foot distance be required between any establishments meeting both of the following criteria:
  - a. Establishment deriving 51% or more of their income from the sale of alcoholic beverages for on-premise consumption; and
  - b. Providing outdoor amplified sound.

The penalties for violating the standards imposed through this rezoning ordinance are found in Section 20.24 of the El Paso City Code.

*(Signatures on following page)*

ORDINANCE NO. \_\_\_\_\_

Zoning Case No: PZRZ22-00009

ADOPTED this \_\_\_\_\_ day of \_\_\_\_\_, 20\_\_.

**THE CITY OF EL PASO:**

\_\_\_\_\_  
Oscar Leeser  
Mayor

**ATTEST:**

\_\_\_\_\_  
Laura D. Prine  
City Clerk

**APPROVED AS TO FORM:**

*Wendi N. Vineyard*  
\_\_\_\_\_  
Wendi N. Vineyard  
Assistant City Attorney

**APPROVED AS TO CONTENT:**

*Philip F. Etiwe*  
\_\_\_\_\_  
Philip F. Etiwe, Director  
Planning & Inspections Department

**ORDINANCE NO.** \_\_\_\_\_

**Zoning Case No: PZRZ22-00009**

**METES AND BOUNDS DESCRIPTION**

Description of a parcel of land being a portion of Nellie D. Mundy Survey No. 244, and being more particularly described by metes and bounds as follows:

Commencing for reference at a ½" rebar with cap marked TX 5152 at the centerline intersection of Hunter Foster Dr. and Resler Dr., as shown on plat of Enchanted Hills Unit Five recorded in Clerks File No. 20210037543, Real Property Records of El Paso County, Texas, from which a ½" rebar with cap marked TX 5152 at the centerline intersection Hunter Foster Dr. and Northwestern Dr. bears, North 85°38'42" West a distance of 1369.92 feet; Thence North 34°43'51" East a distance of 96.55 feet to a set ½" rebar on the easterly right of way line of Resler Dr. for THE "TRUE POINT OF BEGINNING";

Thence, North 00°43'19" East a distance of 65.88 feet to a set ½" rebar with cap marked TX 5152 on the easterly right of way line of Resler Dr.;

Thence, along said right of way line, 103.03 feet along the arc of a curve to the right, which has a radius of 2946.00 feet, a central angle of 02°00'14", a chord which bears North 01°43'26" East a distance of 103.03 feet to a set ½" rebar with cap marked TX 5152;

Thence, continuing along said right of way, North 02°43'33" East a distance of 337.90 feet to a set ½" rebar with cap marked TX 5152;

Thence, leaving said right of way line, South 86°47'10" East a distance of 202.49 feet to a set ½" rebar with cap marked TX 5152;

Thence, North 85°28'03" East a distance 176.12 feet to a set ½" rebar with a cap marked TX 5152 on the westerly line of Block 38, Enchanted Hills Unit Five as recorded in Clerks File No. 20210037543;

Thence, along said line, South 17°19'19" West a distance of 331.54 feet to a set ½" rebar with a cap marked TX 5152;

Thence, along said line, South 03°12'50" West a distance of 252.20 feet to a set 1/2 "rebar on the northerly right of way line of Hunter Foster Dr.;

Thence along said right of way line North 86°47'10" West a distance of 246.59 feet to a set ½" rebar for a point of curve;

Thence 19.98 feet along the arc of a curve to the right, which has a radius of 20.00 feet, a central angle of 57°13'44", a chord which bears North 58°10'18" West a distance of 19.16 feet to a set ½" rebar with cap marked TX 5152 for a point of reverse curve;

Thence, 26.35 feet along the arc of a curve to the left, which has a radius of 89.00 feet, a central angle of 16°57'47", a chord which bears North 38°02'20" West a distance of 26.25 feet to a set ½" rebar with cap marked TX 5152 for a point of reverse curve;

Thence, 16.49 feet along the arc of a curve to the right, which has a radius of 20.00 feet, a central angle of 47°14'32", a chord which bears North 22°53'57" West a distance of 16.03 feet to the "TRUE POINT OF BEGINNING" and containing 173,706 square feet or 3.9877 acres of land more or less.

NOTE: A drawings of even date accompanies this description.



Ron R. Conde  
R.P.L.S. No. 5152  
Job# 122-21



CONDE, INC.  
ENGINEERING / LAND SURVEYING / PLANNING  
6080 SURETY DRIVE SUITE 100 / EL PASO, TEXAS 79936 / (915) 592-0283 FAX (915) 592-0286  
FIRM NO. 10078100

Prepared for: Southwest Land Development Services Inc.  
March 14, 2022  
(Parcel II)

### METES AND BOUNDS DESCRIPTION

Description of a parcel of land being a portion of Nellie D. Mundy Survey 244 and being more particularly described by metes and bounds as follows:

Commencing for reference at a ½” rebar with cap marked TX 5152 for the centerline intersection of Hunter Foster Dr. and Resler Dr., as shown on plat of Enchanted Hills Unit Five recorded in Clerks File No. 20210037543, Real Property Records of El Paso County, Texas, from which a ½” rebar with cap marked TX 5152 at the centerline intersection Hunter Foster Dr. and Northwestern Dr. bears, North 85°38’42” West a distance of 1369.92 feet; Thence South 63°44’07” East a distance of 99.60 feet to a point on the southerly right of way line of Hunter Foster Dr. for THE “TRUE POINT OF BEGINNING”;

Thence along said right of way line, South 86°47’10” East a distance of 419.61 feet to a set ½” rebar with cap marked TX 5152;

Thence along said right of way line, 93.45 feet along the arc of a curve to the right, which has a radius of 2961.00 feet, a central angle of 01°48’30”, a chord which bears South 85°52’55” East a distance of 93.44 feet to a set ½” rebar with cap marked TX 5152;

Thence leaving said right of way line, South 05°01’20” West a distance of 331.91 feet to a set ½” rebar with cap marked TX 5152 on the northerly line of Block 36, Enchanted Hills Unit Five recorded in Clerks File No. 20210037543, Real Property Records of El Paso County, Texas;

Thence along said right of way line, 323.57 feet along the arc of a curve to the left, which has a radius of 841.00 feet, a central angle of 22°02’38”, a chord which bears North 78°15’22” West a distance of 321.57 feet to a set ½” rebar with cap marked TX 5152;

Thence along said line, North 89°16’41” West a distance of 207.83 feet to a set ½” rebar on the easterly right of way line of Resler Dr. (Enchanted Hills Unit Five recorded in Clerks File No. 20210037543, Real Property Records of El Paso County, Texas);

Thence along said right of way line, North 00°43’19” East a distance of 256.19 feet to a set ½” rebar with cap marked TX 5152;

Thence along said right of way line, 16.49 feet along the arc of a curve to the right, which has a radius of 20.00 feet, a central angle of 47°14’32”, a chord which bears North 24°20’35” East a distance of 16.03 feet to a set ½” rebar with cap marked TX 5152 for a point of reverse curve;



Thence, 18.61 feet along the arc of a curve to the left, which has a radius of 89.00 feet, a central angle of  $11^{\circ}58'45''$ , a chord which bears North  $41^{\circ}58'29''$  East a distance of 18.57 feet to a set  $\frac{1}{2}$ " rebar with a cap marked TX. 5152 for a point of reverse curve;

Thence, 19.98 feet along the arc of a curve to the right, which has a radius of 20.00 feet, a central angle of  $57^{\circ}13'44''$ , a chord which bears North  $64^{\circ}35'58''$  East a distance of 19.16 feet to the "TRUE POINT OF BEGINNING" and containing 158,431 square feet or 3.6371 acres of land more or less.

NOTE: A drawings of even date accompanies this description.

  
Ron R. Conde  
R.P.L.S. No. 5152  
Job# 122-21



**CONDE, INC.**  
**ENGINEERING / LAND SURVEYING / PLANNING**  
**6080 SURETY DRIVE SUITE 100 / EL PASO, TEXAS 79936 / (915) 592-0283 FAX (915) 592-0286**  
**FIRM NO. 10078100**

Prepared for: Southwest Land development Services Inc.  
March 14, 2022  
(Parcel III)

### METES AND BOUNDS DESCRIPTION

Description of a parcel of land being a portion of Tracts 9A1, 9B1, Laura E. Mundy Survey 238, and a portion of Nellie D. Mundy Survey No. 244 and being more particularly described by metes and bounds as follows:

Commencing for reference at a ½” rebar with cap marked TX 5152 at the centerline intersection of Hunter Foster Dr. and Resler Dr., as shown on plat of Enchanted Hills Unit Five recorded in Clerks File No. 20210037543, Real Property Records of El Paso County, Texas, from which an ½” rebar with cap marked TX 5152 at the centerline intersection of Hunter Foster Dr. and Northwestern Dr. bears, North 85°38’42” West a distance of 1369.92 feet; Thence South 33°22’01” West a distance of 100.11 feet to a set ½” rebar on the westerly right of way line of Resler Dr. as shown on plat of Enchanted Hills Unit Five recorded in Clerks File No. 20210037543, Real Property Records of El Paso County, Texas, for THE “TRUE POINT OF BEGINNING”;

Thence along said right of way line, South 00°43’19” West a distance of 251.93 feet to a set ½” rebar with cap marked TX 5152 on the northerly line of Block 30, Enchanted Hills Unit Five recorded in Clerks File No. 20210037543, Real Property Records of El Paso County, Texas;

Thence along said line, North 89°16’41” West a distance of 175.97 feet to a set ½” rebar with cap marked TX 5152;

Thence along said line, North 80°36’35” West a distance of 231.44 feet to a set ½” rebar with cap marked TX 5152;

Thence along said line, North 86°47’10” West a distance 692.63 feet to a set ½” rebar with a cap marked TX 5152;

Thence along said line, North 80°10’33” West a distance of 115.37 feet to a set ½” rebar with a cap marked TX 5152;

Thence along said line, North 86°47’10” West a distance of 170.23 feet to a set ½” rebar with a cap marked TX 5152 on the easterly right of way line of Northwestern Drive as shown on plat of Enchanted Hills Unit Five as recorded in Clerks File No. 20210037543 Real Property Records of El Paso County, Texas;

Thence along said right of way line, North 17°43’53” East a distance of 95.54 feet to a set 1/2 “rebar with a cap marked TX. 5152 for a point of curve;

Thence along said right of way line 116.65 feet along the arc of a curve to the right, which has a radius of 500.00 feet, a central angle of 13°22’00”, a chord which bears North 24°24’53” East a distance of 116.38 feet to a set ½” rebar with cap marked TX 5152;

Thence along said right of way line, North 31°05’53” East a distance of 59.09 feet to a set 1/2“rebar with a cap marked TX. 5152 for a point of curve;

**CONDE, INC.**  
**ENGINEERING / LAND SURVEYING / PLANNING**  
**6080 SURETY DRIVE SUITE 100 / EL PASO, TEXAS 79936 / (915) 592-0283 FAX (915) 592-0286**  
**FIRM NO. 10078100**

Thence along said right of way line, 14.18 feet along the arc of a curve to the right, which has a radius of 30.00 feet, a central angle of  $27^{\circ}05'07''$ , a chord which bears North  $44^{\circ}38'26''$  East a distance of 14.05 feet to a set  $\frac{1}{2}$ " rebar with cap marked TX 5152 for a point of reverse curve;

Thence, 10.97 feet along the arc of a curve to the left, which has a radius of 87.00 feet, a central angle of  $7^{\circ}13'28''$ , a chord which bears North  $54^{\circ}34'15''$  East a distance of 10.96 feet to a set  $\frac{1}{2}$ " rebar with cap marked TX 5152 for a point of reverse curve;

Thence, 29.50 feet along the arc of a curve to the right, which has a radius of 40.00 feet, a central angle of  $42^{\circ}15'19''$ , a chord which bears North  $72^{\circ}05'11''$  East a distance of 28.84 feet to a set  $\frac{1}{2}$ " rebar with cap marked TX 5152 on the southerly right of way line of Hunter Foster Dr. as shown on plat of Enchanted Hills Unit Five as recorded in Clerks File No. 20210037543 Real Property Records of El Paso County, Texas;

Thence along said right of way line South  $86^{\circ}47'10''$  East a distance of 474.94 feet to a set  $\frac{1}{2}$ " rebar with cap marked TX 5152 for a point of curve;

Thence along said right of way line, 281.04 feet along the arc of a curve to the right, which has a radius of 2946.00 feet, a central angle of  $05^{\circ}27'57''$ , a chord which bears South  $84^{\circ}03'12''$  East a distance of 280.93 feet to a set  $\frac{1}{2}$ " rebar with cap marked TX 5152 for a point of reverse curve;

Thence along said right of way line, 291.34 feet along the arc of a curve to the left, which has a radius of 3054.00 feet, a central angle of  $5^{\circ}27'57''$ , a chord which bears South  $84^{\circ}03'12''$  East a distance of 291.23 feet to a set  $\frac{1}{2}$ " rebar with cap marked TX 5152;

Thence along said right of way line, South  $86^{\circ}47'10''$  East a distance of 157.78 feet to a set  $\frac{1}{2}$ " rebar with cap marked TX 5152 for a point of curve;

Thence, 16.49 feet along the arc of a curve to the right, which has a radius of 20.00 feet, a central angle of  $47^{\circ}14'32''$ , a chord which bears South  $63^{\circ}09'54''$  East a distance of 16.03 feet to a set  $\frac{1}{2}$ " rebar with cap marked TX 5152 for a point of reverse curve;

Thence, 7.51 feet along the arc of a curve to the left, which has a radius of 89.00 feet, a central angle of  $4^{\circ}50'00''$ , a chord which bears South  $41^{\circ}57'38''$  East a distance of 7.51 feet to a set  $\frac{1}{2}$ " rebar with cap marked TX 5152 for a point of reverse curve;

Thence, 23.61 feet along the arc of a curve to the right, which has a radius of 30.00 feet, a central angle of  $45^{\circ}05'57''$ , a chord which bears South  $21^{\circ}49'40''$  East a distance of 23.01 feet to the "TRUE POINT OF BEGINNING" and containing 382,484 square feet or 8.78 acres of land more or less.

NOTE: A drawings of even date accompanies this description.

  
Ron R. Conde  
R.P.L.S. No. 5152  
Job# 122-21



**ENGINEERING / LAND SURVEYING / PLANNING**  
**6080 SURETY DRIVE SUITE 100 / EL PASO, TEXAS 79936 / (915) 592-0283 FAX (915) 592-0286**  
**FIRM NO. 10078100**

Prepared for: Southwest land Development Services Inc.  
March 14, 2022  
(Parcel IV)

### METES AND BOUNDS DESCRIPTION

Description of a parcel of land being a portion of Tract 9B1, Laura E. Mundy Survey 238, and a portion of Nellie D. Mundy Survey No. 244 and being more particularly described by metes and bounds as follows:

Commencing for reference at a ½” rebar with cap marked TX 5152 at the centerline intersection of Hunter Foster Dr. and Resler Dr., as shown on plat of Enchanted Hills Unit Five recorded in Clerks File No. 20210037543, Real Property Records of El Paso County, Texas, from which a ½” rebar with cap marked TX 5152 at the centerline intersection of Hunter Foster Dr. and Northwestern Dr. bears, North 85°38’42” West a distance of 1369.92 feet; Thence North 52°46’38” West a distance of 96.55 feet to a set ½” rebar on the northerly right of way line of Hunter Foster Dr. for THE “TRUE POINT OF BEGINNING”;

Thence along said right of way line, North 86°47’10” East a distance of 157.78 feet to a set ½” rebar with cap marked TX 5152 on the northerly right of way line of Hunter Foster Dr., Enchanted Hills Unit Five as recorded in Clerks File No. 20210037543;

Thence, along said right of way line, 281.04 feet along the arc of a curve to the right, which has a radius of 2946.00 feet, a central angle of 05°27’57”, a chord which bears North 84°03’12” West a distance of 280.93 feet to a set ½” rebar with cap marked TX 5152 to a point of reverse curve;

Thence along said right of way line, 291.34 feet along the arc of a curve to the left, which has a radius of 3054.00 feet, a central angle of 05°27’57”, a chord which bears North 84°03’12” West a distance of 291.23 feet to a set ½” rebar with cap marked TX 5152;

Thence, North 86°47’10” West a distance of 472.77 feet to a set ½” rebar with a cap marked TX. 5152 for a point of curve;

Thence along said right of way line, 49.92 feet along the arc of a curve to the right, which has a radius of 30.00 feet, a central angle of 95°20’23”, a chord which bears North 39°06’59” West a distance of 44.36 feet to a set ½” rebar with cap marked TX 5152 on the easterly right of way line of Northwestern Dr. as shown in plat of Enchanted Hills Unit Five as recorded in Clerks File No. 20210037543;

Thence along said right of way line, 171.25 feet along the arc of a curve to the left, which has a radius of 1010.00 feet, a central angle of 9°42’52”, a chord which bears North 3°41’46” East a distance of 171.04 feet to a set ½” rebar with cap marked TX 5152 for a point of reverse curve;

Thence along said right of way line, 31.69 feet along the arc of a curve to the right, which has a radius of 990.00 feet, a central angle of 01°50’03”, a chord which bears North 00°14’38” West a distance of 31.69 feet to a set ½” rebar with cap marked TX 5152 for a point of reverse curve;

Thence along said right of way line, 151.29 feet along the arc of a curve to the left, which has a radius of 1132.00 feet, a central angle of 7°39’26”, a chord which bears North 3°09’20” West a distance of 151.17 feet to a set ½” rebar with cap marked TX 5152;

**CONDE, INC.**  
**ENGINEERING / LAND SURVEYING / PLANNING**  
**6080 SURETY DRIVE SUITE 100 / EL PASO, TEXAS 79936 / (915) 592-0283 FAX (915) 592-0286**  
**FIRM NO. 10078100**

Thence, leaving said right of way line, North 65°34'38" East a distance of 361.49 feet to a set ½" rebar with cap marked TX 5152;

Thence, North 87°32'06" East a distance of 171.38 feet to a set ½" rebar with cap marked TX 5152;

Thence, North 51°23'54" East a distance of 92.85 feet to a set ½" rebar with cap marked TX 5152;

Thence, South 86°47'10" East a distance of 117.58 feet to a set ½" rebar with cap marked TX 5152;

Thence, South 73°40'11" East a distance of 191.19 feet to a set ½" rebar with cap marked TX 5152;

Thence, South 87°50'51" East a distance of 206.98 feet to a set ½" rebar with cap marked TX 5152;

Thence, North 70°47'02" East a distance of 206.77 feet to a set ½" rebar with cap marked TX 5152 on the easterly right of way line of Resler Dr;

Thence along said right of way line South 02°43'33" East a distance of 502.70 feet to a set ½" rebar with cap marked TX 5152;

Thence along said right of way line, 106.81 feet along the arc of a curve to the left, which has a radius of 3054.00 feet, a central angle of 2°00'14", a chord which bears South 1°43'26" West a distance of 106.80 feet to a set ½" rebar with cap marked TX 5152;

Thence along said right of way line South 00°43'19" West a distance of 65.88 feet to a set ½" rebar with cap marked TX 5152 to a point of curve;

Thence along said right of way line, 16.49 feet along the arc of a curve to the right, which has a radius of 20.00 feet, a central angle of 47°14'32", a chord which bears South 24°20'35" West a distance of 16.03 feet to a set ½" rebar with cap marked TX 5152 for a point of reverse curve;

Thence along said right of way line, 3.10 feet along the arc of a curve to the left, which has a radius of 89.00 feet, a central angle of 1°59'34", a chord which bears South 46°58'04" West a distance of 3.10 feet to a set ½" rebar with cap marked TX 5152 for a point of reverse curve;

Thence along said right of way line, 16.49 feet along the arc of a curve to the right, which has a radius of 20.00 feet, a central angle of 47°14'32", a chord which bears South 69°35'34" West a distance of 16.03 feet to the "TRUE POINT OF BEGINNING" and containing 727,992.13 square feet or 16.71 acres of land more or less.

NOTE: A drawings of even date accompanies this description.

  
Ron R. Conde  
R.P.L.S. No. 5152  
Job# 122-21



CONDE, INC.  
ENGINEERING / LAND SURVEYING / PLANNING  
6080 SURETY DRIVE SUITE 100 / EL PASO, TEXAS 79936 / (915) 592-0283 FAX (915) 592-0286  
FIRM NO. 10078100

Prepared for: Southwest Land Development Services Inc.  
March 14, 2022  
(Parcel V)

### METES AND BOUNDS DESCRIPTION

Description of a parcel of land being a portion of Tract 9B1, Laura E. Mundy Survey No. 238 and being more particularly described by metes and bounds as follows:

Commencing for reference at a found ½” rebar with cap marked TX 5152 at the centerline intersection of Hunter Foster Dr. and Northwestern Dr as shown on plat of Enchanted Hills Unit Five recorded in Clerks File No. 20210037543, Real Property Records of El Paso County, Texas, from which an existing ½” rebar with cap marked TX 5152 at the centerline intersection of Hunter Foster Dr. and Resler Dr. bears South 85°38’42” East a distance of 1369.92 feet; Thence North 47°56’18” West a distance of 91.34 feet to a set ½” rebar with cap marked TX 5152 on the northerly right of way line of Hunter Foster Dr. for THE “TRUE POINT OF BEGINNING”;

Thence along said right of way line 10.39 feet along the arc of a curve to the right, which has a radius of 30.00 feet, a central angle of 19°51’05”, a chord which bears South 86°58’57” West a distance of 10.34 feet to a set ½” rebar with cap marked TX 5152;

Thence along said right of way line, 214.72 feet along the arc of a curve to the right, which has a radius of 1046.00 feet, a central angle of 11°45’42”, a chord which bears North 77°12’40” West a distance of 214.35 feet to a set ½” rebar with cap marked TX 5152;

Thence along the right of way line, North 71°19’49” West a distance of 333.30 feet to a set ½” rebar with cap marked TX 5152 for a point of curve;

Thence along said right of way line, 242.28 feet along the arc of a curve to the right, which has a radius of 1500.00 feet, a central angle of 9°15’16”, a chord which bears North 66°42’10” West a distance of 242.02 feet to a set ½” rebar with cap marked TX 5152;

Thence along said right of way line, North 62°04’32” West a distance of 236.62 feet to a set ½” rebar marked TX. 5152 for a point of curve;

Thence along said right of way line, 754.42 feet along the arc of a curve to the left, which has a radius of 1400.00 feet, a central angle of 30°52’30”, a chord which bears North 77°30’47” West a distance of 745.33 feet to a set ½” rebar with a cap marked TX. 5152 for a point of reverse curve;

Thence along said right of way line, 540.65 feet along the arc of a curve to the right, which has a radius of 1250.00 feet, a central angle of 24°46’53”, a chord which bears North 80°33’36” West a distance of 536.44 feet to a set ½” rebar with cap marked TX 5152;

Thence, 25.86 feet along the arc of a curve to the right, which has a radius of 20.00 feet, a central angle of  $74^{\circ}04'33''$ , a chord which bears North  $31^{\circ}07'53''$  West a distance of 24.09 feet to a set  $\frac{1}{2}$ " rebar with cap marked TX 5152 for a point of reverse curve on the proposed easterly right of way line of Enchanted Pass Dr.;

Thence along said right of way line, 24.75 feet along the arc of a curve to the left, which has a radius of 532.00 feet, a central angle of  $02^{\circ}39'57''$ , a chord which bears North  $04^{\circ}34'25''$  East a distance of 24.75 feet to a set  $\frac{1}{2}$ " rebar with a cap marked TX. 5152;

Thence along said line, North  $03^{\circ}14'26''$  East a distance of 162.10 feet to a set  $\frac{1}{2}$ " rebar with cap marked TX 5152 on the proposed southerly line of Block 45, Enchanted Hills Unit Six;

Thence along said line, South  $71^{\circ}31'47''$  East a distance 234.67 feet to a set  $\frac{1}{2}$ " rebar with cap marked TX 5152;

Thence along said line, North  $82^{\circ}03'08''$  East a distance of 39.00 feet set  $\frac{1}{2}$ " rebar with cap marked TX 5152;

Thence along said line, North  $23^{\circ}54'34''$  East a distance of 33.50 feet set  $\frac{1}{2}$ " rebar with cap marked TX 5152;

Thence along said line; South  $66^{\circ}41'48''$  East a distance of 242.72 feet set  $\frac{1}{2}$ " rebar with cap marked TX 5152;

Thence along said line, North  $79^{\circ}02'54''$  East a distance of 133.59 feet set  $\frac{1}{2}$ " rebar with cap marked TX 5152;

Thence along said line, South  $84^{\circ}41'38''$  East a distance of 116.47 feet set  $\frac{1}{2}$ " rebar with cap marked TX 5152;

Thence along said line, South  $79^{\circ}01'29''$  East a distance of 809.44 feet set  $\frac{1}{2}$ " rebar with cap marked TX 5152;

Thence along said line, South  $87^{\circ}57'04''$  East a distance of 182.04 feet set  $\frac{1}{2}$ " rebar with cap marked TX 5152;

Thence along said line, North  $83^{\circ}14'23''$  East a distance of 521.82 feet set  $\frac{1}{2}$ " rebar with cap marked TX 5152 on the proposed westerly right of way line of Northwestern Dr. out of Enchanted Hills Unit Six.


Thence along said right of way line, 351.08 feet along the arc of a curve to the right, which has a radius of 1068.00 feet, a central angle of  $18^{\circ}50'05''$ , a chord which bears South  $10^{\circ}15'27''$  East a distance of 349.50 feet to a set  $\frac{1}{2}$ " rebar with cap marked TX 5152;

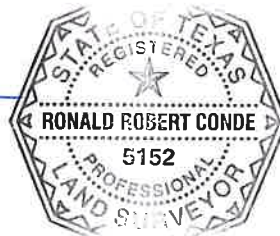
Thence along said right of way line, 192.02 feet along the arc of a curve to the right, which has a radius of 590.00 feet, a central angle of 18°38'51", a chord which bears South 08°29'01" West a distance of 191.18 feet to a set ½" rebar with cap marked TX 5152;

Thence along said right of way line, South 17°48'27" West a distance of 29.09 feet to a set ½" rebar with cap marked TX 5152 for a point of curve.

Thence, 56.88 feet along the arc of a curve to the right, which has a radius of 55.00 feet, a central angle of 59°14'58", a chord which bears South 47°25'56" West a distance of 54.38 feet to the "TRUE POINT OF BEGINNING" and containing 679,808 square feet or 15.61 acres of land more or less.

NOTE: A drawings of even date accompanies this description.

  
Ron R. Conde  
R.P.L.S. No. 5152  
Job# 122-21



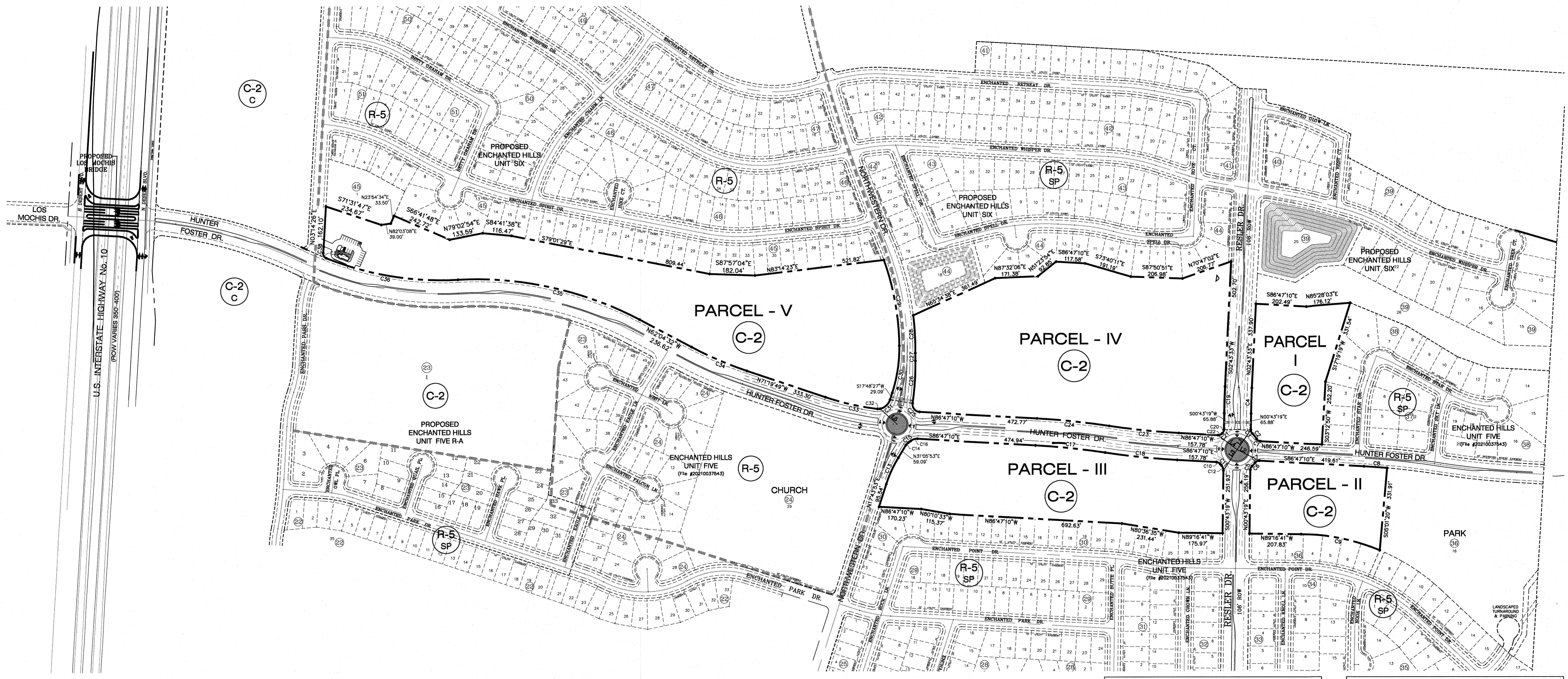
**CONDE, INC.**  
**ENGINEERING / LAND SURVEYING / PLANNING**  
**6080 SURETY DRIVE SUITE 100 / EL PASO, TEXAS 79936 / (915) 592-0283 FAX (915) 592-0286**  
**FIRM NO. 10078100**



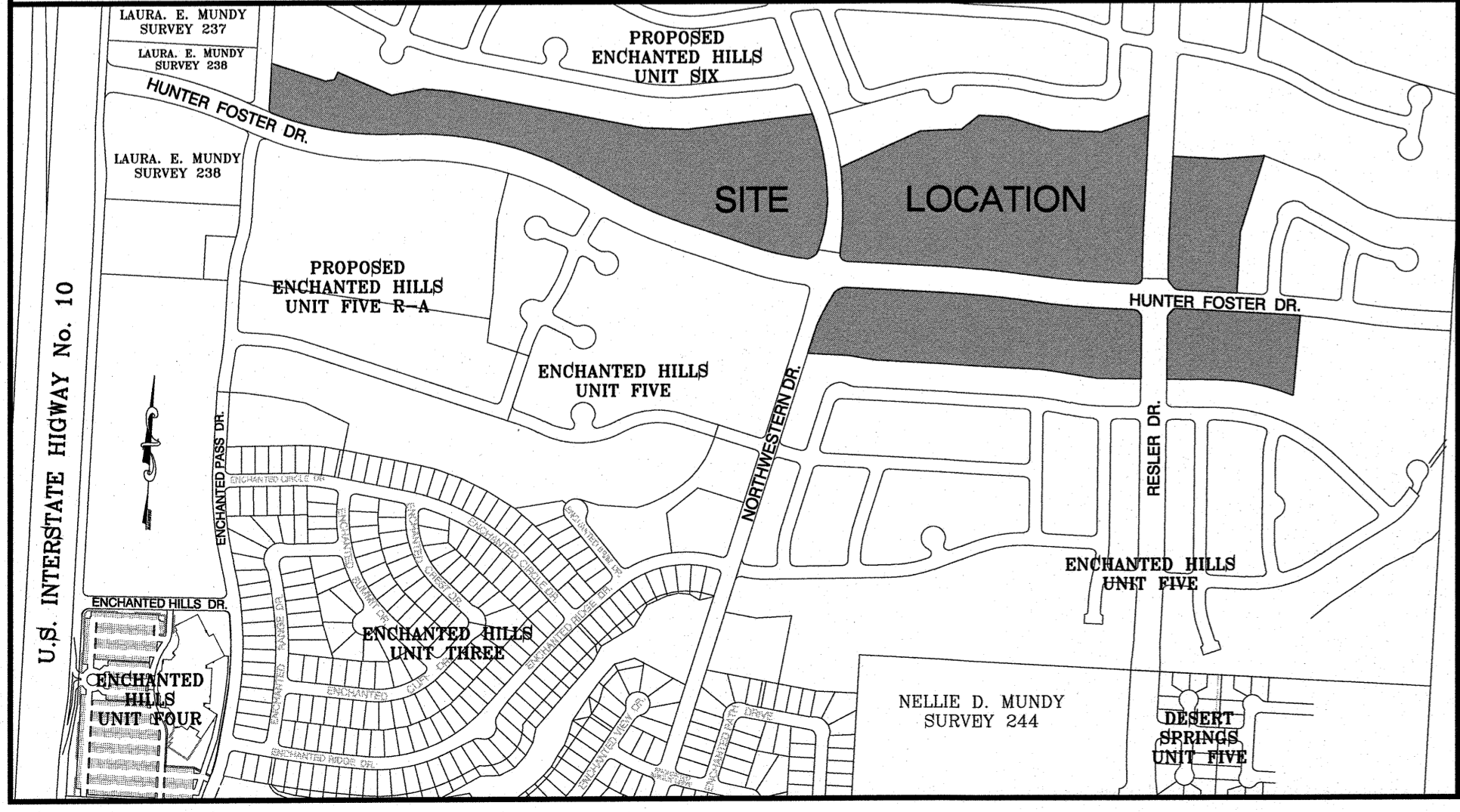
# REZONING PLAN

BEING A PORTION OF TRACTS 9A1, AND 9B1, LAURA E. MUNDY SURVEY 238, AND PORTION OF NELLIE D. MUNDY SURVEY 244, CITY OF EL PASO, EL PASO COUNTY, TEXAS

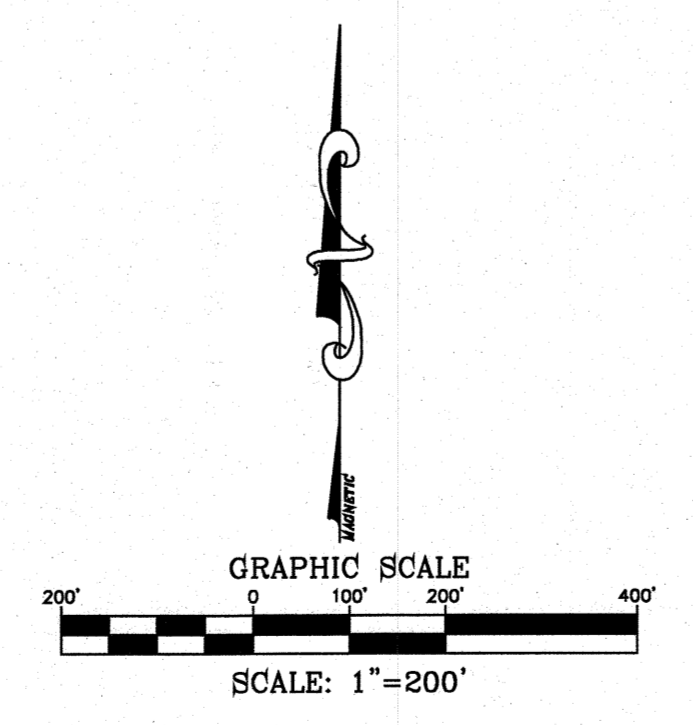
NOTES:  
 1. SET 1" REBAR WITH CAPS MARKED TX 6162 ON ALL CORNERS UNLESS OTHERWISE NOTED.  
 2. A METES AND BOUNDS DESCRIPTION OF EVEN DATE ACCOMPANIES THIS DRAWING.



LOCATION MAP SCALE: 1" = 600'



- RESIDENTIAL
- COMMERCIAL
- APPARTEMNT
- OPEN SPACE/PARKS/PONDS



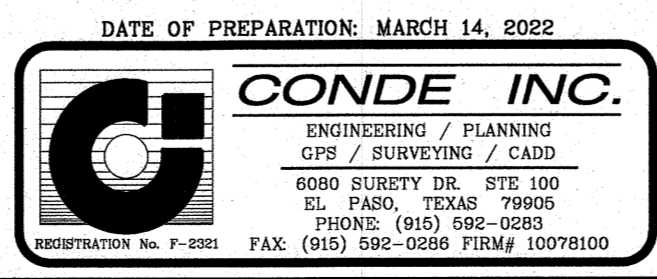
CURVE TABLE						
CURVE	RADIUS	LENGTH	TANGENT	CHORD	BEARING	DELTA
C1	20.00'	19.98'	10.91'	19.16'	N58°0'16"W	57°13'44"
C2	89.00'	26.35'	13.27'	26.25'	N38°02'20"W	16°57'47"
C3	20.00'	16.49'	8.75'	16.03'	N22°53'57"W	47°14'32"
C4	2946.00'	103.03'	51.52'	103.03'	N1°43'26"E	2°00'14"
C5	20.00'	16.49'	8.75'	16.03'	N24°20'35"E	47°14'32"
C6	89.00'	18.61'	9.34'	18.57'	N41°58'29"E	11°58'45"
C7	20.00'	19.98'	10.91'	19.16'	N64°35'58"E	57°13'44"
C8	2961.00'	93.45'	46.73'	93.44'	S85°52'55"E	1°48'30"
C9	841.00'	323.57'	163.81'	321.57'	N78°15'22"W	22°02'38"
C10	20.00'	16.49'	8.75'	16.03'	S63°09'54"E	47°14'32"
C11	89.00'	7.51'	3.76'	7.51'	S41°57'38"E	4°50'00"
C12	30.00'	23.61'	12.46'	23.01'	S21°49'40"E	45°05'57"
C13	500.00'	116.65'	58.59'	116.38'	N24°24'53"E	13°22'00"
C14	30.00'	14.18'	7.23'	14.05'	N44°38'26"E	27°05'07"
C15	87.00'	10.97'	5.49'	10.96'	N54°34'16"E	7°13'28"
C16	40.00'	29.50'	15.46'	28.84'	N72°05'11"E	42°15'19"
C17	2946.00'	281.04'	140.62'	280.93'	S84°03'12"E	52°7'57"
C18	3054.00'	291.34'	145.78'	291.23'	S84°03'12"E	52°7'57"
C19	3054.00'	106.81'	53.41'	106.80'	S1°43'26"W	2°00'14"

CURVE TABLE						
CURVE	RADIUS	LENGTH	TANGENT	CHORD	BEARING	DELTA
C20	20.00'	16.49'	8.75'	16.03'	S24°20'35"W	47°14'32"
C21	89.00'	3.10'	1.55'	3.10'	S46°58'04"W	1°59'34"
C22	20.00'	16.49'	8.75'	16.03'	S69°35'34"W	47°14'32"
C23	2946.00'	281.04'	140.62'	280.93'	N84°03'12"E	52°7'57"
C24	3054.00'	291.34'	145.78'	291.23'	N84°03'12"E	52°7'57"
C25	30.00'	49.82'	32.93'	44.36'	N39°06'59"W	95°20'23"
C26	1010.00'	171.25'	85.83'	171.04'	N3°41'46"E	9°42'52"
C27	990.00'	31.69'	15.85'	31.69'	N01°43'38"W	1°50'03"
C28	1132.00'	151.29'	75.76'	151.17'	N3°09'20"W	7°39'26"
C29	1068.00'	351.08'	177.14'	349.50'	N10°15'27"W	18°50'05"
C30	590.00'	192.02'	96.87'	191.17'	N8°29'01"E	18°38'51"
C31	55.00'	56.88'	31.28'	54.37'	N47°25'56"E	59°14'58"
C32	30.00'	10.39'	5.25'	10.34'	N66°58'57"E	19°51'05"
C33	1046.00'	214.72'	107.74'	214.35'	S77°12'40"E	11°45'42"
C34	1500.00'	242.28'	121.41'	242.02'	S66°42'10"E	9°15'16"
C35	1400.00'	794.42'	386.61'	745.33'	N77°30'47"W	30°52'30"
C36	1250.00'	540.65'	274.62'	536.44'	S80°33'36"E	24°46'53"
C37	20.00'	25.86'	15.09'	24.09'	S31°07'53"E	74°04'33"
C38	532.00'	24.75'	12.38'	24.75'	N4°34'26"E	2°39'57"

LINE TABLE		
LINE	LENGTH	BEARING
L1	96.55'	N34°43'51"E
L2	99.60'	S63°44'07"E
L3	100.11'	S33°22'01"W
L4	96.55'	N52°46'38"W
L5	91.34'	N47°56'18"W

PARCEL	ACRES	PROPOSED ZONING	EXISTING ZONING
I	3.9877	C-2	R-5 SP
II	3.6371	C-2	R-5 SP
III	8.78	C-2	R-5 SP
IV	16.70	C-2	R-5 SP
V	16.61	C-2	R-5

DATE OF PREPARATION: MARCH 14, 2022




CERTIFICATION  
 THIS PLAT REPRESENTS A SURVEY MADE ON THE GROUND BY ME OR UNDER MY SUPERVISION AND IS TRUE AND CORRECT TO THE BEST OF MY KNOWLEDGE AND BELIEF BASED ON THE FACTS EXISTING AT THE TIME OF THIS SURVEY.

RON R. CONDE  
 REGISTERED PROFESSIONAL LAND SURVEYOR  
 TEXAS LICENSE NO. 5162



# Northwestern Drive, Resler Drive, Hunter Foster Avenue

City Plan Commission — May 5, 2022 **(REVISED)**



<b>CASE NUMBER:</b>	<b>PZR22-00009</b>
<b>CASE MANAGER:</b>	Andrew Salloum, (915) 212-1603, <a href="mailto:SalloumAM@elpasotexas.gov">SalloumAM@elpasotexas.gov</a>
<b>PROPERTY OWNER:</b>	EP Transmountain Residential, LLC
<b>REPRESENTATIVE:</b>	Conde, Inc.
<b>LOCATION:</b>	Generally North of Transmountain Rd. and East of Interstate 10 (District 1)
<b>PROPERTY AREA:</b>	48.71 acres
<b>REQUEST:</b>	Rezone from R-5/c (Residential/conditions) to C-2/c (Commercial/conditions) and R-5/sp (Residential/special permit) to C-2 (Commercial)
<b>RELATED APPLICATIONS:</b>	None
<b>PUBLIC INPUT:</b>	None received as of April 28, 2022

**SUMMARY OF REQUEST:** The applicant is requesting to rezone the subject property from R-5/c (Residential/conditions) to C-2/c (Commercial/conditions) and R-5/sp (Residential/special permit) to C-2 (Commercial) for commercial development.

**SUMMARY OF STAFF'S RECOMMENDATION:** Staff recommends **APPROVAL WITH CONDITIONS** of the rezoning request as the proposed rezoning is in keeping with the policies of the G-4 Suburban (walkable) Land Use Designation of *Plan El Paso*, the City's adopted Comprehensive Plan. The conditions are the following:

1. That a ten-foot (10') landscaped buffer with high-profile native or naturalized trees of at least two-inch (2") caliper and ten feet (10') in height shall be placed at twenty feet (20') on center along the property lines adjacent to residential zone districts or uses. The landscaped buffer shall be irrigated and maintained by the property owner at all times and shall be installed prior to the issuance of any certificates of occupancy.
  - a. This condition shall not apply where the existing arroyo will serve as a natural buffer between the subject properties and residential zone districts or uses.
  - b. The landscaping required under this condition will count towards the landscaping required under Title 18.
2. That a detailed site development plan shall be reviewed and approved per the El Paso City Code prior to the issuance of building permits.
3. That a minimum 500-foot distance be required between any establishments meeting both of the following criteria:
  - a. Establishment deriving 51% or more of their income from the sale of alcoholic beverages for on-premise consumption; and
  - b. Providing outdoor amplified sound.

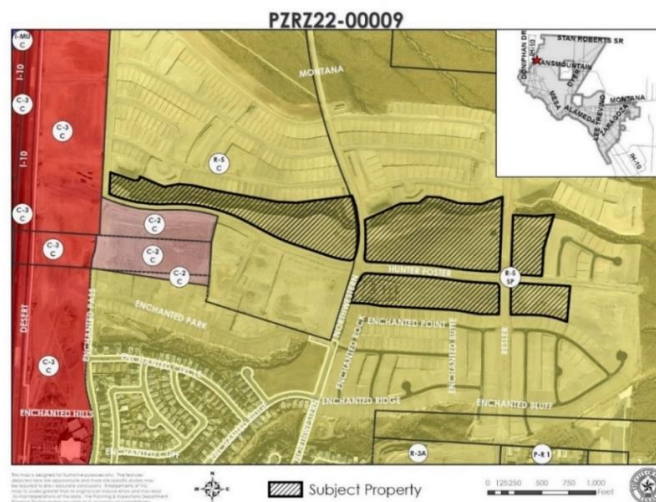


Figure A. Subject Property & Immediate Surroundings

**DESCRIPTION OF REQUEST:** The applicant is requesting to rezone the subject property from R-5/c (Residential/conditions) to C-2/c (Commercial/conditions) and R-5/sp (Residential/special permit) to C-2 (Commercial) for commercial development. The property consists of 48.71 acres. Although the arroyo is part of the rezoning request, the arroyo areas will remain undeveloped. The subject property is located in the Hillside Development Area. This rezoning request is to satisfy Condition No. 4 of Ordinance No. 19286.

**PREVIOUS CASE HISTORY:** On April 20, 1982, City Council made a motion to approve the Special Permit No. 81-18 to allow for the borrow pit (see Attachment no. 5). The existing special permit designation will be repealed once the new rezoning designation request is approved.

Ordinance No. 16948 approved by City Council on July 29, 2008, rezoned portions of the subject property into C-3 (Commercial), R-5/sp (Residential/special permit), and R-MU (Residential Mixed Use). Additionally, a Master Zoning Plan was approved for the R-MU (Residential Mixed Use) properties and conditions were imposed for the C-3 (Commercial) zoned properties (see Attachment no. 6). The conditions are the following:

- *A detailed site development plan shall be reviewed approved per the El Paso City Code prior to the issuance of building permits.*
- *A ten (10) foot landscaped buffer be placed abutting all residential uses.*

Additionally, the Enchanted Hills Land Study (SUB08-00038) was approved by City Plan Commission on June 5, 2008. The approved Land Study proposed to develop the area into multiple commercial and residential developments with a portion of subject property not having been part of the study.

Ordinance No. 19286 approved by City Council on February 1, 2022, rezoned portions of the subject property into three (3) different zoning districts: Parcel 1 – from R-MU (Residential Mixed Use) to R-5 (Residential) for proposed residential development; Parcel 2 - from R-3 (Residential), R-5 (Residential), and R-MU (Residential Mixed Use) to C-2 (Commercial) for proposed commercial development; and Parcel 3 - from R-3 (Residential) to C-3 (Commercial) for proposed commercial development (see Attachment no. 7). The conditions are the following:

1. *On Parcel 2, a ten-foot (10') landscaped buffer with high-profile native or naturalized trees of at least two-inch (2") caliper and ten feet (10') in height shall be placed at fifteen feet (15') on center along the property lines adjacent to residential zone districts or uses. The landscaped buffer shall be irrigated and maintained by the property owner at all times and shall be installed prior to the issuance of any certificates of occupancy.*
2. *That a detailed site development plan shall be reviewed and approved per the El Paso City Code prior to the issuance of building permits for Parcel 2.*
3. *That a detailed site development plan shall be reviewed and approved per the El Paso City Code prior to the issuance of building permits for Parcel 3.*
4. *That prior to the issuance of certificates of occupancy for Parcel 1, 2, and 3, the rezonings for the properties identified as "future commercial" on Exhibit B be submitted and processed by the City.*

Note: Condition No. 4 is being satisfied by this rezoning request.

**COMPATIBILITY WITH NEIGHBORHOOD CHARACTER:** The subject property is proposed to be developed into residential and commercial developments. Surrounding properties are undeveloped with abutting properties to the north and east zoned R-5 (Residential). Properties to the south are zoned R-5 (Residential) and C-2 (Commercial) along I-10. Properties to the west are zoned C-3 (Commercial). Proposed commercial developments will have access to the existing and proposed extension of Northwestern Drive and Resler Drive, which are designated and proposed to continue as a collector and major arterial, respectively as per El Paso's Major Thoroughfare Plan (MTP). Also, proposed commercial developments will have access to the proposed Hunter Foster Drive, which is designated as a collector as per El Paso's MTP. The classification of these roads are appropriate for the proposed developments.

<b>COMPLIANCE WITH PLAN EL PASO/REZONING POLICY – When evaluating whether a proposed rezoning is in accordance with <i>Plan El Paso</i>, consider the following factors:</b>	
<b>Criteria</b>	<b>Does the Request Comply?</b>
<p><b>Future Land Use Map:</b> Proposed zone change is compatible with the Future Land Use designation for the property:</p> <p><b>G-4, Suburban (Walkable):</b> This sector applies to modern single-use residential subdivisions and office parks, large schools and parks, and suburban shopping centers. This sector is generally stable but would benefit from strategic suburban retrofits to supplement the limited housing stock and add missing civic and commercial uses.</p>	<p><b>Yes.</b> The subject property is proposed to be developed into residential and commercial developments, which are in character with the future land use designation of <i>Plan El Paso</i>.</p>
<p><b>Compatibility with Surroundings:</b> The proposed zoning district is compatible with those surrounding the site:</p> <p><b>C-2 (Commercial):</b> The purpose of these districts is to accommodate establishments providing goods or rendering services which are used in support of the community's trade and service establishments and serving multi-neighborhoods within a planning area of the city. The regulations of the districts will permit intensities designed to be compatible with each other and to provide for a wide range of types of commercial activity, including light automobile related uses.</p>	<p><b>Yes.</b> The proposed C-2 (Commercial) zoning district is the same as the adjacent zoning district to the southwest. The proposed C-2 (Commercial) zoning district will be adjacent to C-3 (Commercial) to the west and be of lower intensity as it will abut residential. The proposed commercial developments have the potential to provide goods and render services to the nearby area and in character with the spirit of the R-5 (Residential) and C-2 (Commercial) zone districts.</p>
<p><b>Preferred Development Locations:</b> Located along an arterial (or greater street classification) or the intersection of two collectors (or greater street classification). The site for proposed rezoning is not located mid-block, resulting in it being the only property on the block with an alternative zoning district, density, use and/or land use.</p>	<p><b>Yes.</b> Proposed commercial developments will have access to the existing and proposed extension of Northwestern Drive and Resler Drive, which are designated and proposed to continue as a collector and major arterial, respectively as per El Paso's MTP. Also, proposed commercial developments will have access to the proposed Hunter Foster Drive, which is designated as a collector as per El Paso's MTP. The classification of these roads are appropriate for the proposed developments.</p>
<b>THE PROPOSED ZONING DISTRICT'S EFFECT ON THE PROPERTY AND SURROUNDING PROPERTY, AFTER EVALUATING THE FOLLOWING FACTORS:</b>	
<p><b>Historic District or Special Designations &amp; Study Area Plans:</b> Any historic district or other special designations that may be applicable. Any adopted small areas plans, including land-use maps in those plans.</p>	<p>The property lies within the Hillside Development Area. The Open Space Advisory Board (OSAB) recommendation is pending with the hearing scheduled for May 11, 2022.</p>
<p><b>Potential Adverse Effects:</b> Potential adverse effects that might be caused by approval or denial of the requested rezoning.</p>	<p>No adverse effects are anticipated by the rezoning of the subject property.</p>
<p><b>Natural Environment:</b> Anticipated effects on the natural environment.</p>	<p>The subject property lies within the Hillside Development Area. There are no anticipated effects on the natural environment. Furthermore, the Open Space Advisory Board (OSAB) meeting is scheduled for May 11, 2022 for the board's recommendation.</p>
<p><b>Stability:</b> Whether the area is stable or in transition.</p>	<p>The area is in transition as is currently under development. It is expected to be developed into a residential and commercial subdivisions along Northwestern Drive and as commercial developments along Interstate 10.</p>

**COMPLIANCE WITH *PLAN EL PASO*/REZONING POLICY – When evaluating whether a proposed rezoning is in accordance with *Plan El Paso*, consider the following factors:**

<b>Socioeconomic &amp; Physical Conditions:</b> Any changed social, economic, or physical conditions that make the existing zoning no longer suitable for the property.	None.
-------------------------------------------------------------------------------------------------------------------------------------------------------------------------	-------

**ADEQUACY OF PUBLIC FACILITIES, SERVICES AND INFRASTRUCTURE:** Proposed commercial developments will have access to the existing and proposed extension of Northwestern Drive and Resler Drive, which are designated and proposed to continue as a collector and major arterial, respectively as per El Paso’s MTP. Also, proposed commercial developments will have access to the proposed Hunter Foster Drive, which is designated as a collector as per El Paso’s MTP. The classification of these roads are appropriate for the proposed developments. Additionally, the subject property will need to provide adequate infrastructure at the time of platting and prior to development.

**SUMMARY OF DEPARTMENTAL REVIEW COMMENTS:** No adverse comments from reviewing departments.

**PUBLIC COMMENT:** The property does not lie within any neighborhood associations. As required, public notices were mailed to property owners within 300 feet on April 21, 2022. As of April 28, 2022, the Planning Division did not receive any communication in support or opposition to the request from the public.

**RELATED APPLICATIONS:** None.

**CITY PLAN COMMISSION OPTIONS:**

The purpose of the Zoning Ordinance is to promote the health, safety, morals and general welfare of the City. The City Plan Commission (CPC) has the authority to advise City Council on Zoning matters. In evaluating the request, the CPC may take any of the following actions:

1. **Recommend Approval** of the rezoning request, finding that the request is in conformance with the review criteria of *Plan El Paso* as reflected in the Staff Report, or that the request is in conformance with other criteria that the CPC identifies from the Comprehensive Plan.
2. **Recommend Approval of the rezoning request With Modifications** to bring the request into conformance with the review criteria of *Plan El Paso* as reflected in the Staff Report, or other criteria that the CPC identifies from the Comprehensive Plan. **(Staff Recommendation)**
3. **Recommend Denial** of the rezoning request, finding that the request does not conform to the review criteria of *Plan El Paso* as reflected in the Staff Report, or other criteria that the CPC identifies from the Comprehensive Plan.

**ATTACHMENTS:**

1. Future Land Use Map
2. Neighborhood Notification Boundary Map
3. Generalized Plot Plan
4. Department Comments
5. Special Permit SP-81-18
6. Ordinance No. 16948
7. Ordinance No. 19286







# ATTACHMENT 2

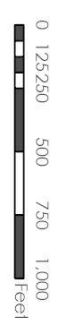
PZR22-00009



This map is designed for illustrative purposes only. The features depicted here are approximate and more site-specific studies may be required to draw accurate conclusions. Engagements of this map to scales greater than 1:50,000 can induce errors and may lead to misinterpretations of the data. The Planning & Inspection Department Planning Division makes no claim to its accuracy or completeness.



 Subject Property







# **ATTACHMENT 4**

## **Planning and Inspections Department - Planning Division**

Staff recommend approval with the following conditions:

1. That a ten-foot (10') landscaped buffer with high-profile native or naturalized trees of at least two-inch (2") caliper and ten feet (10') in height shall be placed at twenty feet (20') on center along the property lines adjacent to residential zone districts or uses. The landscaped buffer shall be irrigated and maintained by the property owner at all times and shall be installed prior to the issuance of any certificates of occupancy.
  - a. This condition shall not apply where the existing arroyo will serve as a natural buffer between the subject properties and residential zone districts or uses.
  - b. The landscaping required under this condition will count towards the landscaping required under Title 18.
2. That a detailed site development plan shall be reviewed and approved per the El Paso City Code prior to the issuance of building permits.
3. That a minimum 500-foot distance be required between any establishments meeting both of the following criteria:
  - a. Establishment deriving 51% or more of their income from the sale of alcoholic beverages for on-premise consumption; and
  - b. Providing outdoor amplified sound.

## **Planning and Inspections Department – Plan Review & Landscaping Division**

No objections to proposed rezoning.

Note: At the time of submittal for building permit, the project will need to comply with all applicable provisions of the ICC, TAS and Municipal Code.

## **Planning and Inspections Department – Land Development**

No objections to proposed rezoning.

Note: Stormwater drainage has been verified. Rainwater harvesting is recommended at time of development.

## **Fire Department**

Recommend approval. No adverse comments.

## **Police Department**

No comments received.

## **Environment Services**

No adverse comments.

## **Streets and Maintenance Department**

No TIA updated required.

## **Texas Department of Transportation**

No comments received.

**Sun Metro**

No comments received.

**El Paso Water**

No comments received.

**El Paso Water – Stormwater Engineering**

- The parcels north of Hunter Foster Dr. are accommodated in the Drainage Plans for Enchanted Hills Unit 6 and the parcels on the south are accommodated in the Drainage Plans for Enchanted Hills Unit 5.
- EPWater-SW recommends using principles of low impact development (such as recessed landscaping, rainwater harvesting, and porous pavement) to reduce the amount of developed stormwater runoff.

**El Paso County 911 District**

The 911 District has no comments or concerns regarding this zoning.

**El Paso County Water Improvement District #1**

Not within the boundaries of EPCWID1.

# ATTACHMENT 5

## MOTION

April 20, 1982

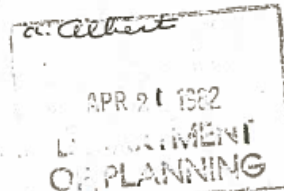
Motion made, seconded and carried that the Land Reclamation Plan for Special Permit #SP-81-18 (in connection with the Borrow Pit, 24.12+/- Acres, Tract 8 Laura E. Mundy Survey #238) be approved as submitted by the applicant, to include the restoration of native plants and topsoil necessary for the growth of said plants, and the vote was as follows:

Ayes: Council Members Scherr, Wagner, Haggerty and Escobar.

Nays: Council Members Fonseca and Divis.

W. L. Rieger, City Clerk

cc: City Engineer  
City Planning Department  
City Attorney



# ATTACHMENT 6

Doc# 20080063082

10G  
15/14

CITY CLERK DEPT.

08 JUL 30 AM 8:50

ORDINANCE NO. 016948

AN ORDINANCE CHANGING THE ZONING OF THE FOLLOWING REAL PROPERTY DESCRIBED AS:

**PARCEL 1:** A PORTION OF TRACTS 8, 9A, 9B1 AND 9C, LAURA E. MUNDY SURVEY NO. 238, CITY OF EL PASO, EL PASO COUNTY, TEXAS, BE CHANGED FROM R-3 (RESIDENTIAL) TO C-3 (COMMERCIAL) AND IMPOSING CONDITIONS; AND,

**PARCEL 2:** A PORTION OF TRACTS 8, 9A, 9B1 AND 9C, LAURA E. MUNDY SURVEY NO. 238, AND A PORTION OF TRACTS 5A, 5B AND 6, LAURA E. MUNDY SURVEY NO. 237 AND A PORTION OF NELLIE D. MUNDY SURVEY NO. 244, CITY OF EL PASO, EL PASO COUNTY, TEXAS, BE CHANGED FROM R-3 (RESIDENTIAL) TO R-5 (RESIDENTIAL) AND FROM R-3/SP (RESIDENTIAL/SPECIAL PERMIT) TO R-5/SP (RESIDENTIAL/SPECIAL PERMIT); AND,

**PARCEL 3:** A PORTION OF TRACTS 9A, 9B1 AND 9B, LAURA E. MUNDY SURVEY NO. 238 AND A PORTION OF TRACT 4B, 4B1, 5A, 5B AN 6, LAURA E. MUNDY SURVEY NO. 237, CITY OF EL PASO, EL PASO COUNTY, TEXAS, BE CHANGED FROM R-3 (RESIDENTIAL) TO R-MU (RESIDENTIAL MIXED USE) AND APPROVING A MASTER ZONING PLAN; AND,

**PARCEL 4:** A PORTION OF TRACTS 9B, LAURA E. MUNDY SURVEY NO. 238, AND A PORTION OF TRACTS 4A, 4B, 4B1, AND 6, LAURA E. MUNDY SURVEY NO. 237 CITY OF EL PASO, EL PASO COUNTY, TEXAS, BE CHANGED FROM R-3 (RESIDENTIAL) TO C-3 (COMMERCIAL) AND IMPOSING CONDITIONS. THE PENALTY IS AS PROVIDED FOR IN CHAPTER 20.24 OF THE EL PASO CITY CODE.

**NOW THEREFORE, BE IT ORDAINED BY THE CITY COUNCIL OF THE CITY OF EL PASO:**

That the zoning of the following property be changed as described below within the meaning of the zoning ordinance and that the zoning map of the City of El Paso be revised accordingly:

**Parcel 1:** *A portion of Tracts 8, 9A, 9B1 and 9C, Laura E. Mundy Survey No. 238, El Paso County, Texas, and more particularly described by metes and bounds on the attached Exhibit "A", incorporated by reference, be changed from R-3 (Residential) to C-3 (Commercial) and imposing conditions; and,*

Doc #40071v2./Planning/Ord/ZON08-00016 (Rezoning w/conditions)/LCUE

ORDINANCE NO. 016948

Zoning Case No: ZON08-00016

**Parcel 2:** A portion of Tracts 8, 9A, 9B1 and 9C, Laura E. Mundy Survey No. 238, and a portion of Tracts 5A, 5B and 6, Laura E. Mundy Survey No. 237 and a portion of Nellie D. Mundy Survey No. 244, City of El Paso, El Paso County, Texas, and more particularly described by metes and bounds on the attached Exhibit "B", incorporated by reference, be changed from **R-3 (Residential)** to **R-5 (Residential)** and from **R-3/sp (Residential/special permit)** to **R-5/sp (Residential/special permit)**; and,

**Parcel 3:** A portion of Tracts 9A, 9B1, and 9B, Laura E. Mundy Survey No. 238, and a portion of Tracts 4B, 4B1, 5A, 5B, and 6, Laura E. Mundy Survey No. 237, City of El Paso, El Paso County, Texas, and more particularly described by metes and bounds on the attached Exhibit "C", incorporated by reference, be changed from **R-3 (Residential)** to **R-MU (Residential Mixed Use)** and approving a Master Zoning Plan, included as Exhibit "E" to this Ordinance; and,

**Parcel 4:** A portion of Tracts 9B, Laura E. Mundy Survey No. 238, and a portion of Tracts 4A, 4B, 4B1, and 6, Laura E. Mundy Survey No. 237, City of El Paso, El Paso County, Texas, and more particularly described by metes and bounds on the attached Exhibit "D", incorporated by reference, be changed from **R-3 (Residential)** to **C-3 (Commercial)** and imposing conditions.

Further, that the property described above be subject to the following conditions which are necessitated by and attributable to the increased density of use generated by the change of zoning in order to protect the health, safety and welfare of the adjacent property owners and the residents of this City:

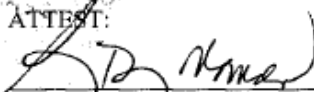
Parcels 1 and 4

A detailed site development plan shall be reviewed approved per the El Paso City Code prior to the issuance of building permits.


A ten (10) foot landscaped buffer be placed abutting all residential uses.

**PASSED AND APPROVED** this 29<sup>th</sup> day of July, 2008.

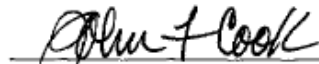
ATTEST:

  
Richarda Duffy Momsen  
City Clerk

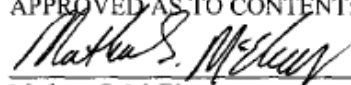
APPROVED AS TO FORM:

  
Lupe Cuellar  
Assistant City Attorney

THE CITY OF EL PASO

  
John F. Cook  
Mayor

APPROVED AS TO CONTENT:

  
Mathew S. McElroy  
Deputy Director - Planning  
Development Services Department

CITY CLERK DEPT  
08 JUL 30 AM 8:50

Doc #40071v2./Planning/Ord/ZON08-00016 (Rezoning w/conditions)/LCUE

**ORDINANCE NO. 016948**

**Zoning Case No: ZON08-00016**

**Exhibit "A"**

**Parcel 1 (C-4)**

Being a **42.11 acre** portion of Tracts 8, 9A, 9B1, and 9C,  
Laura E. Mundy Survey #238,  
City of El Paso, El Paso County, Texas,  
February 15, 2008

**METES AND BOUNDS DESCRIPTION**

Description of a parcel of land being a **42.11 acre** portion of Tracts 8, 9A, 9B1, and 9C, Laura E. Mundy Survey #238, City of El Paso, El Paso County, Texas, and being more particularly described by metes and bounds as follows:

Commencing for reference at a found 2" pipe held for the southeast corner of Laura E. Mundy Survey #238 and the northeast corner of Nellie D. Mundy Survey #239, from which a found 1" pipe held for the southeast corner of Nellie D. Mundy Survey #239 bears South 00°00'02" West a distance of 4,100.21 feet, a found 1" pipe held for the northeast corner of Laura E. Mundy Survey #238 bears North 00°00'02" East a distance of 4,047.02 feet, and a found 1" pipe held for the northwest corner of Nellie D. Mundy Survey #244 bears North 00°00'02" East a distance of 4,790.13 feet; Thence with the common line of Surveys #239 and #238, North 89°59'58" West a distance of 2,654.05 feet to the "TRUE POINT OF BEGINNING".

Thence continuing along said line, **North 89°59'58" West** a distance of **599.59** feet to a point at the westerly right of way line of U.S. Highway No. 10;

Thence with said right of way, **North 00°01'47" East** a distance of **1,091.00** feet to a point of inverse;

Thence with said right of way, **North 07°09'17" East** a distance of **201.56** feet to a point of inverse;

Thence with said right of way, **North 00°01'47" East** a distance of **1,789.53** feet to a point the southwest corner of Tract 9B2;

Thence along a line common to said Tract 9B2 and Tract 9B1, **North 89°59'55" East** a distance of **559.44** feet to a point;

Thence leaving said common line, **South 00°01'37" West** a distance of **960.78** feet to a point of curvature;

Thence, **243.55** feet along the arc of a curve to the left which has a radius of **750.00** feet, a central angle of **18°36'21"**, a tangent of 122.86 feet, and a chord which bears South 09°16'33" East a distance of 242.48 feet to a point of tangency;

Thence, **South 18°34'44" East** a distance of **34.63** feet to a point of curvature;

2022 MAY 5 10 59 AM  
COUNTY CLERK  
EL PASO COUNTY, TEXAS

**Exhibit "A"**

Thence, **567.48** feet along the arc of a curve to the right which has a radius of **1,000.00** feet, a central angle of **32°30'51"**, a tangent of 291.61 feet, and a chord which bears South 02°19'18" East a distance of 559.90 feet to a point of tangency;

Thence, **South 13°56'07" West** a distance of **120.12** feet to a point of curvature;


Thence, **242.75** feet along the arc of a curve to the left which has a radius of **1,000.00** feet, a central angle of **13°54'31"**, a tangent of 121.98 feet, and a chord which bears South 06°58'52" West a distance of 242.16 feet to a point of tangency;

Thence, **South 00°01'36" West** a distance of **931.24** feet to "**TRUE POINT OF BEGINNING**" and containing in all **1,834,203** square feet or **42.11** acres of land more or less.

A Zoning Map dated February 15, 2008 accompanies this metes and bounds description.

016948  
R.R. CONDE  
2/15/08



  
Ron R. Conde  
R.P.L.S. No. 5152

job 1207-76

**CONDE, INC.**  
**ENGINEERING / LAND SURVEYING / PLANNING**  
**1790 LEE TREVINO SUITE 400 / EL PASO, TEXAS 79936 / (915) 592-0283**

**016948**

**Exhibit "B"**

**Parcel 2 (R-5)**

Being a portion of Tracts 8, 9A, 9B1, and 9C,  
Laura E. Mundy Survey #238, and  
A portion of Tracts 5A, 5B, and 6,  
Laura E. Mundy Survey #237, and  
A portion of Nellie D. Mundy Survey #244,  
City of El Paso, El Paso County, Texas,  
February 15, 2008

CITY OF EL PASO  
COUNTY CLERK  
OFFICE

**METES AND BOUNDS DESCRIPTION**

Description of a parcel of land being a portion of Tracts 8, 9A, 9B1, and 9C, Laura E. Mundy Survey #238, and a portion of Tracts 5A, 5B, and 6, Laura E. Mundy Survey #237, and a portion of Nellie D. Mundy Survey #244, City of El Paso, El Paso County, Texas, and being more particularly described by metes and bounds as follows:

The **"TRUE POINT OF BEGINNING"** being a found 2" pipe held for the southeast corner of Laura E. Mundy Survey #238 and the northeast corner of Nellie D. Mundy Survey #239, from which a found 1" pipe held for the southeast corner of Nellie D. Mundy Survey #239 bears South 00°00'02" West a distance of 4,100.21 feet, a found 1" pipe held for the northeast corner of Laura E. Mundy Survey #238 bears North 00°00'02" East a distance of 4,047.02 feet, and a found 1" pipe held for the northwest corner of Nellie D. Mundy Survey #244 bears North 00°00'02" East a distance of 4,790.13 feet;

Thence with the common line of Surveys #239 and 238, **North 89°59'58" West** a distance of **2,654.05** feet to a point;

Thence leaving said line, **North 00°01'36" East** a distance of **931.24** feet to a point of curvature;

Thence, **242.75** feet along the arc of a curve to the right which has a radius of **1,000.00** feet, a central angle of **13°54'31"**, a tangent of 121.98 feet, and a chord which bears North 06°58'52" East a distance of 242.16 feet to a point of tangency;

Thence, **North 13°56'07" East** a distance of **120.12** feet to a point of curvature;

Thence, **567.48** feet along the arc of a curve to the left which has a radius of **1,000.00** feet, a central angle of **32°30'51"**, a tangent of 291.61 feet, and a chord which bears North 02°19'18" West a distance of 559.90 feet to a point of tangency;

Thence, **North 18°34'44" West** a distance of **34.63** feet to a point of curvature;

Thence, **243.55** feet along the arc of a curve to the right which has a radius of **750.00** feet, a central angle of **18°36'21"**, a tangent of 122.86 feet, and a chord which bears North 09°16'33" West a distance of 242.48 feet to a point of tangency;

Thence, **North 00°01'37" East** a distance of **960.78** feet to a point at the south line of Tract 9B2;

Thence along a line common to said Tract 9B2 and Tract 9B1, **North 89°59'55" East** a distance of **1,065.94** feet to a point at the southeast corner of Tract 9B2;

Thence leaving said line, **South 00°00'05" East** a distance of **242.13** feet to a point;

Thence, **South 75°28'56" East** a distance of **1,226.61** feet to a point;

Thence, **North 14°31'04" East** a distance of **621.01** feet to a point of curvature;



**Exhibit "B"**

Thence, **878.36** feet along the arc of a curve to the left which has a radius of **1,250.00** feet, a central angle of **40°15'39"**, a tangent of 458.18 feet, and a chord which bears North 05°36'46" West a distance of 860.39 feet to a point of reverse curvature;

Thence, **3239.16** feet along the arc of a curve to the right which has a radius of **5,250.00** feet, a central angle of **35°21'02"**, a tangent of 1672.99 feet, and a chord which bears North 08°04'04" West a distance of 3188.03 feet to a point;

Thence, **South 89°59'59" East** a distance of **790.09** feet to a point at a line common to Laura E. Mundy Survey #237 and Nellie D. Mundy Survey #245;

Thence with said common line, **South 00°00'05" East** a distance of **2,354.76** feet to a found 1" pipe held for the northwest corner of Nellie D. Mundy Survey #244 and the southwest corner of Nellie D. Mundy Survey #245;

Thence with the common line of said Surveys #244 and #245, **North 89°59'36" East** a distance of **2,371.12** feet to a found 1 1/2" pipe held for the northeast corner of Nellie D. Mundy Survey #244;

Thence with the east line of said Survey #244, **South 00°00'19" West** a distance of **3,122.87** feet to a found 1" pipe held for the southeast corner of the northerly 170 acres of Nellie D. Mundy Survey #244 as referenced by that parcel described in Book 2354, Page 1678, recorded with the El Paso County Real Property Records;

Thence with the south line said parcel, **South 89°59'35" West** a distance of **2,370.86** feet to a point at a line common to Nellie D. Mundy Survey #244 and Laura E. Mundy Survey #238, from which a found 1 1/2" pipe bears North 89°59'35" East a distance of 0.23 feet;

Thence with said common line, **South 00°00'02" West** a distance of **1,667.24** feet to **"TRUE POINT OF BEGINNING"** and containing in all **17,578,546 square feet** or **403.55 acres** of land more or less.

A Zoning Map dated February 15, 2008 accompanies this metes and bounds description.

06 APR 03 AM 10:06  
1776 W. W. W. W. W.



job 1207-76

Ron R. Conde  
R.P.L.S. No. 5152

**CONDE, INC.**  
**ENGINEERING / LAND SURVEYING / PLANNING**  
**1790 LEE TREVINO SUITE 400 / EL PASO, TEXAS 79936 / (915) 592-0283**

**Exhibit "C"**

**Parcel 3 (RMU)**

Being a portion of Tracts 9A, 9B1, and 9B,  
Laura E. Mundy Survey #238, and  
a portion of Tracts 4B, 4B1, 5A, 5B, and 6,  
Laura E. Mundy Survey #237,  
City of El Paso, El Paso County, Texas,  
February 15, 2008

90-2013-00137-05  
LAW OFFICE OF JEFFREY T. HARRIS

**METES AND BOUNDS DESCRIPTION**

Description of a parcel of land being a portion of Tracts 9A, 9B1, and 9B, Laura E. Mundy Survey #238, and a portion of Tracts 4B, 4B1, 5A, 5B, and 6, Laura E. Mundy Survey #237, City of El Paso, El Paso County, Texas, and being more particularly described by metes and bounds as follows:

The "TRUE POINT OF BEGINNING" being a found ½" rebar with cap "TX 4869" at the northeast corner of Laura E. Mundy Survey #237 and the southeast corner of Laura E. Mundy Survey #234, from which a found 1" pipe held for the northwest corner of Nellie D. Mundy Survey #244 bears North 00°00'02" East a distance of 4,790.13 feet;

Thence with the east line of said Survey #237, **South 00°00'05" East** a distance of **875.00** feet to a point;

Thence leaving said survey line, **North 89°59'59" West** a distance of **790.09** feet to a point on a curve;

Thence, **3,239.16** feet along the arc of a curve to the left which has a radius of **5,250.00** feet, a central angle of **35°21'02"**, a tangent of 1672.99 feet, and a chord which bears South 08°04'04" East a distance of 3188.03 feet to a point of reverse curvature;

Thence, **878.36** feet along the arc of a curve to the right which has a radius of **1,250.00** feet, a central angle of **40°15'39"**, a tangent of 458.18 feet, and a chord which bears South 05°36'46" East a distance of 860.39 feet to a point of tangency;

Thence, **South 14°31'04" West** a distance of **621.01** feet to a point;

Thence, **North 75°28'56" West** a distance of **1,226.61** feet to a found ½" rebar with cap "TX 2027" at the northeast corner of Tract 9B2 and the southeast corner of Tract 9B;

Thence along a line common to said Tracts 9B2 and Tract 9B, **North 00°00'05" West** a distance of **552.81** feet to a point;

**Exhibit "C"**

Thence leaving said line, **South 89°59'55" West** a distance of **1,000.78** feet to a point;

Thence, **North 00°01'37" East** a distance of **3,092.86** feet to a point;

Thence, **North 16°42'09" East** a distance of **348.49** feet to a point;

Thence, **North 00°01'37" East** a distance of **1,201.94** feet to a point at a line common to Laura E. Mundy Survey #237 and Laura E. Mundy Survey #234;

Thence with said common line, **North 89°59'55" East** a distance of **2,500.24** feet to **"TRUE POINT OF BEGINNING"** and containing in all **10,366,445** square feet or **237.98** acres of land more or less.

A Zoning Map dated February 15, 2008 accompanies this metes and bounds description.

902141 1000000  
1100 2000 3000



*R R Conde*  
Ron R. Conde  
R.P.L.S. No. 5152  
2/28/25

job 1207-76

**CONDE, INC.**  
**ENGINEERING / LAND SURVEYING / PLANNING**  
**1790 LEE TREVINO SUITE 400 / EL PASO, TEXAS 79936 / (915) 592-0283**

**016948**

**Exhibit "D"**

**Parcel 4 (C-4)**

Being a portion of Tracts 9B,  
Laura E. Mundy Survey #238, and  
a portion of Tracts 4A, 4B, 4B1, and 6,  
Laura E. Mundy Survey #237,  
City of El Paso, El Paso County, Texas,  
February 15, 2008

**METES AND BOUNDS DESCRIPTION**

Description of a parcel of land being a portion of Tracts 9B, Laura E. Mundy Survey #238, and a portion of Tracts 4A, 4B, 4B1, and 6, Laura E. Mundy Survey #237, City of El Paso, El Paso County, Texas, and being more particularly described by metes and bounds as follows:

Commencing for reference at a found  $\frac{3}{4}$ " rebar with cap "TX 4869" at the northeast corner of Laura E. Mundy Survey #237 and the southeast corner of Laura E. Mundy Survey #234, from which a found 1" pipe held for the northwest corner of Nellie D. Mundy Survey #244 bears North 00°00'02" East a distance of 4,790.13 feet; Thence along a line common to Laura E. Mundy Survey #237 and Laura E. Mundy Survey #234, South 89°59'55" West a distance of 2,500.24 feet to the "TRUE POINT OF BEGINNING".

Thence leaving said line, South 00°01'37" West a distance of 1,201.94 feet to a point;

Thence, South 16°42'09" West a distance of 348.49 feet to a point;

Thence, South 00°01'37" West a distance of 3,092.86 feet to a point at a line common to Tracts 9B2 and Tract 9B;

Thence with said common line, South 89°59'55" West a distance of 624.42 feet to a point at the westerly right of way line of U.S. Highway No. 10;

Thence with said right of way, North 00°01'47" East a distance of 100.41 feet to a point;

Thence with said right of way, North 07°05'43" West a distance of 201.56 feet to a point;

Thence with said right of way, North 00°01'47" East a distance of 3,025.86 feet to a point;

Thence with said right of way, North 45°01'47" East a distance of 141.42 feet to a found 4"x 4" concrete TX.D.O.T right of way marker;

**Exhibit "D"**

Thence with said right of way, **South 89°58'13" East** a distance of **375.00** feet to a found 4"x 4" concrete TX.D.O.T right of way marker;

Thence with said right of way, **North 00°01'47" East** a distance of **550.15** feet to a found 4"x 4" concrete TX.D.O.T right of way marker;

Thence with said right of way, **North 89°58'13" West** a distance of **375.00** feet to a found 4"x 4" concrete TX.D.O.T right of way marker;

Thence with said right of way, **North 44°58'13" West** a distance of **141.42** feet to a found 4"x 4" concrete TX.D.O.T right of way marker;

Thence with said right of way, **North 00°01'47" East** a distance of **552.15** feet to a point at the intersection of said right of way line with the common line of Laura E. Mundy Survey #237 and Laura E. Mundy Survey #234;

Thence with said common line, **North 89°59'55" East** a distance of **749.20** feet to "**TRUE POINT OF BEGINNING**" and containing in all **2,865,943** square feet or **65.79** acres of land more or less.

A Zoning Map dated revised February 15, 2008 accompanies this metes and bounds description.

50-2114 09 JAN 09  
1:20:00 PM  
2-28-08



job 1207-76

R R Conde  
Ron R. Conde  
R.P.L.S. No. 5152

**CONDE, INC.**  
**ENGINEERING / LAND SURVEYING / PLANNING**  
**1790 LEE TREVINO SUITE 400 / EL PASO, TEXAS 79936 / (915) 592-0283**

**016948**

ENCHANTED HILLS  
MASTER ZONING PLAN

Date: February 18, 2008

To encourage the following: mixture of housing types and densities, preserve open space areas, provide multi-modal form of transportation (pedestrian friendly), mixed use (residential, office, commercial), and to provide form and continuity of building and street scopes.

The 2025 El Paso Comprehensive Plan designates this area as Mixed-Use and a portion as Industrial. The proposed Enchanted Hills Master Plan does Relationship to Comprehensive Plan designates the I-10 Frontage as Heavy Commercial / Industrial, then the Mixed Use area, transitioned to and Single Family as we move toward the Franklin Plan: Mountains.

Proposed Land Use	Permitted Developments	Setbacks	Lot Coverage	Building Height	Building Footprint	Phase	Timing
1.00 Agricultural	n/a	n/a	50%	10' Front / 10' Side	25 Maximum	Landscape Only	10 10 years
Veterinary Treatment (Small)	n/a	1/2 Acre Minimum	50%	10' Front / 10' Side	25 Maximum	Landscape Only	10 10 years
2.00 Commercial Storage:	n/a	1/2 Acre Minimum	75%	n/a	25 Maximum	Landscape Only	10 10 years
Self Storage	n/a	1/2 Acre Minimum	75%	n/a	25 Maximum	Landscape Only	10 10 years
3.00 Educational:	1%	n/a	75%	n/a	45 Maximum	n/a	10 10 years
Art Gallery	n/a	n/a	75%	n/a	45 Maximum	n/a	10 10 years
Child Care Facility	n/a	1/2 Acre Minimum	50%	n/a	25 Maximum	n/a	5 5 years
Church	n/a	1 Acre Minimum	50%	20' Front / 10' Side / 20' Rear	45 Maximum	Landscape Only	10 10 years
Community Recreational Center	n/a	1 Acre Minimum	50%	n/a	45 Maximum	Landscape Only	10 10 years
Library / Museum	n/a	1/2 Acre Minimum	75%	n/a	45 Maximum	n/a	10 10 years
School	n/a	5 Acre Minimum	50%	20' Front / 10' Side / 20' Rear	45 Maximum	Landscape Only	10 10 years
4.00 Office	3%	n/a	75%	20' Rear	25 Maximum	Landscape Only	5 5 years
Bank / ATM	n/a	1/2 Acre Minimum	75%	20' Rear	25 Maximum	Landscape Only	5 5 years
Offices (Business, Medical, Professional)	n/a	n/a	75%	n/a	45 Maximum	n/a	5 5 years
Studio (Dance/Music/Photography)	n/a	n/a	75%	n/a	45 Maximum	n/a	5 5 years
5.00 Medical	2%	n/a	75%	n/a	25 Maximum	Landscape Only	10 10 years
Clinic	n/a	n/a	75%	n/a	25 Maximum	Landscape Only	10 10 years
Drug Store/Pharmacy	n/a	n/a	75%	n/a	25 Maximum	Landscape Only	5 5 years

POOR QUALITY ORIGINAL  
BEST AVAILABLE IMAGE

LO:24114 05/26/09  
3:33:00 PM

Exhibit "E"

ENCHANTED HILLS  
MASTER ZONING PLAN

Date: February 18, 2008

Use	Percent of Development	Density	Lot Size	Lot Coverage	Yard Setbacks	Building Height	Setbacks	Phase	Trimming
Hospital		n/a	1 Acre Minimum	50%	20' Front / 10' Side / 20' Rear	45' Maximum	Landscape Only	10	10 years
Assisted Living (Elderly Care)			1 Acre Minimum	50%	n/a	25' Maximum	Landscape Only	5	5 years
Personal Services	2%		n/a						
Berger Shop/Beauty Salon		n/a	n/a	75%	n/a	25' Maximum	n/a	5	5 years
Dry Cleaning		n/a	2,500 Sq. Ft.	75%	n/a	25' Maximum	n/a	5	5 years
Laundromat		n/a	n/a	75%	n/a	25' Maximum	n/a	5	5 years
Shoe Shop/Repair		n/a	n/a	75%	n/a	25' Maximum	n/a	5	5 years
Recreational	25%								
Athletic Facility		n/a	n/a	50%	n/a	45' Maximum	Landscape Only	5	5 years
Open Space		n/a	n/a	50%	n/a	n/a	n/a	1	1 years
Park		n/a	n/a		n/a	n/a	n/a	3	3 years
Racquetball Club		n/a	1 Acre Maximum	75%	n/a	45' Maximum	Landscape Only	10	10 years
Swimming Pool		n/a	2 Acre Maximum	75%	10' Front / 10' Side / 20' Rear	45' Maximum	Landscape Only	10	10 years
Tennis Club		n/a	4 Acre Maximum	75%	10' Front / 10' Side / 20' Rear	25' Maximum	Landscape Only	10	10 years
Residential	60%								
Apartment	(10%)	14 / Acres	n/a	75%	n/a	45' Maximum	n/a	1	1 year
Duplex	(6%)	6 / Acres	6,000 Sq. Ft. Minimum	50%	10' Front / 15' Rear	25' Maximum	n/a	1	1 year
Quadraplex	(2%)	10 / Acres	8,000 Sq. Ft. Minimum	50%	10' Front / 15' Rear	25' Maximum	n/a	1	1 year
Single Family (Attached/Detached)	(40%)	14 / Acres	5,000 Sq. Ft. / 4,000 Sq. Ft. Minimum	50%	10' Front / 15' Rear	25' Maximum	n/a	1	1 year
Triplex	(2%)	8 / Acres	7,000 Sq. Ft. Minimum	50%	10' Front / 15' Rear	25' Maximum	n/a	1	1 year
Sales	7%								
Bakery		n/a	n/a	75%	n/a	25' Maximum	n/a	5	5 years
Book Store		n/a	n/a	75%	n/a	25' Maximum	n/a	5	5 years
Bedroom		n/a	n/a	75%	n/a	25' Maximum	n/a	5	5 years
Convenience Store w/ Gas Pump		n/a	1/4 Acre Minimum	50%	10' Front / 10' Side / 20' Rear	25' Maximum	n/a	5	5 years
Delicatessen		n/a	n/a	75%	n/a	25' Maximum	n/a	5	5 years

POOR QUALITY ORIGINAL  
BEST AVAILABLE IMAGE

1:250 (Scale)

ENCHANTED HILLS  
MASTER ZONING PLAN

Date: February 18, 2008

Proposed Land Use	Percentage of Development	Density	Lot Size	Lot Coverage	Yard Setbacks	Building Height	Buffers	Phase	Timing
Flower Shop	n/a	n/a	n/a	75%	n/a	25' Maximum	n/a	5	5 years
Grocery	n/a	n/a	n/a	75%	n/a	25' Maximum	n/a	5	5 years
Ice Cream Parlor	n/a	n/a	n/a	75%	n/a	25' Maximum	n/a	5	5 years
Misc Store	n/a	n/a	n/a	75%	n/a	25' Maximum	n/a	5	5 years
Nursery (Green House)	n/a	n/a	1/2 Acre Minimum	25%	10' Front / 10' Side / 20' Rear	25' Maximum	n/a	5	5 years
Office Retail (Low Volume)	n/a	n/a	n/a	75%	n/a	25' Maximum	n/a	5	5 years
Package Liquor Store	n/a	n/a	n/a	50%	10' Front / 10' Side / 20' Rear	25' Maximum	n/a	5	5 years
Shopping Center Community	n/a	n/a	8 Acre Minimum			25' Maximum	Landscape Only	5	5 years
<b>17.00</b> Towers Personal Services Wireless Facility (17.02-17.05)		n/a	n/a	n/a	n/a	n/a	Landscape Only	5	5 years
<b>19.00</b> Utility & Miscellaneous Government Use Building Major Utility Facility		n/a	n/a	75%	n/a	25' Maximum	Landscape Only	5	5 years
Proposed mix of uses:		n/a	n/a	75%	n/a	25' Maximum	Landscape Only	5	5 years

A. Residential/ Office/Retail: to include 13.0 (Single Family, Duplex and Triplex); 4.0 (Business office); 14.0 (other retail low volume, convenience store)

B. Multi-Family/ Office/ Commercial: to include 1.0; 2.0; 4.0; 6.0; 10.0; 13.0 (Apartment, and Quadplex); 14.0; 17.0; and 19.0

C. Educational/ Recreational/ Office/ Retail: to include 3.0; 11.0; 4.0 (Studio); 14.0 (book store, delicatessen, Ice Cream Parlor)

POOR QUALITY ORIGINAL  
BEST AVAILABLE IMAGE

016948

LO-ENTR 06/08/08  
LAW OFFICE



# ATTACHMENT 7

47

019286

ORDINANCE NO. \_\_\_\_\_

AN ORDINANCE CHANGING THE ZONING OF THE FOLLOWING REAL PROPERTY KNOWN AS:

**PARCEL 1: A PORTION OF TRACTS 4B, 4B1, 5A, 5A1, AND 6, LAURA E. MUNDY SURVEY 237; TRACTS 9B AND 9B1, LAURA E. MUNDY SURVEY NO. 238; AND PORTION OF ENCHANTED HILLS UNIT FIVE, CITY OF EL PASO, EL PASO COUNTY, TEXAS, FROM R-MU (RESIDENTIAL MIXED USE) TO R-5 (RESIDENTIAL) AND,**

**PARCEL 2: A PORTION OF TRACTS 9B, 9B1, AND 9B2, LAURA E. MUNDY SURVEY NO. 238; AND PORTION OF LOTS 2 THRU 5, 9 THRU 12, AND 21 THRU 24, BLOCK 23, ENCHANTED HILLS 5, CITY OF EL PASO, EL PASO COUNTY, TEXAS, FROM R-3 (RESIDENTIAL), R-5/SP (RESIDENTIAL/SPECIAL PERMIT), AND R-MU (RESIDENTIAL MIXED USE) TO C-2 (COMMERCIAL); AND,**

**PARCEL 3: A PORTION OF TRACT 9B2, LAURA E. MUNDY SURVEY NO. 238, CITY OF EL PASO, EL PASO COUNTY, TEXAS, FROM R-3 (RESIDENTIAL) TO C-3 (COMMERCIAL), AND IMPOSING CONDITIONS.**

THE PENALTY IS AS PROVIDED FOR IN CHAPTER 20.24 OF THE EL PASO CITY CODE.

**NOW THEREFORE, BE IT ORDAINED BY THE CITY COUNCIL OF THE CITY OF EL PASO:**

Pursuant to Section 20.04.360 of the El Paso City Code, that the zoning of *Parcel 1: a portion of Tracts 4B, 4B1, 5A, 5A1, and 6, Laura E. Mundy Survey 237; Tracts 9B and 9B1, Laura E. Mundy Survey No. 238; and portion of Enchanted Hills Unit Five*, located in the City of El Paso, El Paso County, Texas, and as more particularly described by metes and bounds on the attached **Exhibit "A"**, incorporated by reference; and, *Parcel 2: a portion of Tracts 9B, 9B1, and 9B2, Laura E. Mundy Survey No. 238; and portion of Lots 2 thru 5, 9 thru 12, and 21 thru 24, Block 23, Enchanted Hills 5*, located in the City of El Paso, El Paso County, Texas, and as more particularly described by metes and bounds on the attached **Exhibit "A"**, incorporated by reference; and, *Parcel 3: a portion of Tract 9B2, Laura E. Mundy Survey No. 238*, located in the City of El Paso, El Paso County, Texas, and as more particularly described by metes and bounds on the attached **Exhibit "A"**, incorporated by reference; be changed as listed for **PARCEL 1: FROM R-MU (RESIDENTIAL MIXED USE) TO R-5 (RESIDENTIAL); PARCEL 2: FROM R-3 (RESIDENTIAL), R-5/SP (RESIDENTIAL/SPECIAL PERMIT), AND R-MU (RESIDENTIAL MIXED USE) TO C-2 (COMMERCIAL); and PARCEL 3: FROM R-3 (RESIDENTIAL) TO C-3 (COMMERCIAL)**, as defined in Section 20.06.020, and that the zoning map of the City of El Paso be revised accordingly.

Further, that the property described above be subject to the following conditions which are necessitated by and attributable to the increase of use intensity generated by the change of zoning in order to protect the health, safety and welfare of the residents of the City:

ORDINANCE NO. **019286**

Zoning Case No: PZRZ21-00024

Rezoning Ordinance | PZRZ21-00024 | Northwestern | Hunter Foster | Enchanted Pass  
21-1007-2823 | 1133725 | EAS

1. On Parcel 2, a ten-foot (10') landscaped buffer with high-profile native or naturalized trees of at least two-inch (2") caliper and ten feet (10') in height shall be placed at thirty feet (30') on center along the property lines adjacent to residential zone districts or uses. The landscaped buffer shall be irrigated and maintained by the property owner at all times and shall be installed prior to the issuance of any certificates of occupancy.
2. That a detailed site development plan shall be reviewed and approved per the El Paso City Code prior to the issuance of building permits for Parcel 2.
3. That a detailed site development plan shall be reviewed and approved per the El Paso City Code prior to the issuance of building permits for Parcel 3.
4. That prior to the issuance of certificates of occupancy for Parcel 1, 2, and 3, the rezonings for the properties identified as "future commercial" on Exhibit B be submitted and processed by the City.

The penalties for violating the standards imposed through this rezoning ordinance are found in Section 20.24 of the El Paso City Code.

ADOPTED this 1st day of February, 2022.



THE CITY OF EL PASO:  
Oscar Leeser  
 Oscar Leeser  
 Mayor

APPROVED AS TO FORM:

Evy A. Sotelo  
 Evy A. Sotelo  
 Assistant City Attorney

APPROVED AS TO CONTENT:

Philip F. Etiwe  
 Philip F. Etiwe, Director  
 Planning & Inspections Department

**019286**

ORDINANCE NO. \_\_\_\_\_ Zoning Case No: **PZRZ21-00024**  
 Rezoning Ordinance | PZRZ21-00024 | Northwestern | Hunter Foster | Enchanted Pass  
 21-1007-2823 | 1133725 | EAS

EXHIBIT "A"

Prepared for: Southwest Land Development Services  
August 9, 2021. (Parcel I)

METES AND BOUNDS DESCRIPTION

Description of a parcel of land being a portion of Tracts 4B, 4B1, 5A, 5A1, and 6, Laura E. Mundy Survey 237; Tracts 9B and 9B1, Laura E. Mundy Survey No. 238; and portion of Enchanted Hills Unit Five as recorded in Clerks File No. 20210037543, Real Property Records of El Paso County, Texas, and being more particularly described by metes and bounds as follows:

Commencing for reference at a City of El Paso brass disk monument at the centerline intersection of Enchanted Path Drive and Enchanted Circle Dr., as shown on plat of Enchanted Hills Unit Three recorded in Clerks File No. 20210037543, Real Property Records of El Paso County, Texas, from which an existing brass disk City monument at the centerline intersection of Enchanted Pass Drive and Enchanted Park Drive bears, North 04°47'05" East a distance of 595.27 feet; Thence North 64°48'49" East a distance of 1241.03 feet to a point for THE "TRUE POINT OF BEGINNING";

Thence, North 03°12'44" East a distance of 242.18 feet to a set ½" rebar with cap marked TX 5152 on the westerly boundary line of Block 23 out of Enchanted Hills 5 recorded in Clerks File No. 20210037543, Real Property Records of El Paso County, Texas;

Thence along said boundary line, North 03°12'50" East a distance of 310.68 feet to a set ½" rebar with cap marked TX 5152;

Thence along said boundary line, North 14°04'05" East a distance of 195.56 feet to a set ½" rebar with cap marked TX 5152 on the southerly right of way line of Hunter Foster Drive;

Thence along said right of way line, 450.82 feet along the arc of a curve to the left, which has a radius of 1292.00 feet, a central angle of 19°59'33", a chord which bears North 82°57'16" West a distance of 448.54 feet to a set ½" rebar with cap marked TX 5152;

Thence along said right of way line, 598.55 feet along the arc of a curve to the right, which has a radius of 1358.00 feet, a central angle of 25°15'13", a chord which bears North 80°19'26" West a distance of 593.72 feet to a set ½" rebar with cap marked TX 5152;

Thence leaving said right of way, North 03°14'26" East a distance of 2803.92 feet to a set ½" rebar with cap marked TX 5152 point;

Thence, North 19°54'58" East a distance of 348.49 feet to a set ½" rebar with cap marked TX 5152;

Thence, North 03°14'26" East a distance of 1202.02 feet to a set ½" rebar with cap marked TX 5152 on the common line of Laura E. Mundy Surveys No. 234 and 237;

Thence along said line, South 86°47'10" East a distance of 2500.24 feet to a set ½" rebar with cap marked TX 5152 on the common line of Laura E. Mundy Surveys No. 234 and 245;

Thence along said line, South 03°12'50" West a distance of 875.00 feet to a set ½" rebar with cap marked TX 5152;

CONDE, INC.  
ENGINEERING / LAND SURVEYING / PLANNING  
6080 SURETY DRIVE SUITE 100 / EL PASO, TEXAS 79936 / (915) 592-0283 FAX (915) 592-0286  
FIRM NO. 10078100



Thence leaving said line, North  $86^{\circ}47'10''$  West a distance of 790.06 feet to a set  $\frac{1}{2}$ " rebar with cap marked TX 5152 for a point of curve;

Thence, 3239.16 feet along the arc of a curve to the left, which has a radius of 5250.00 feet, a central angle of  $35^{\circ}21'02''$ , a chord which bears South  $04^{\circ}51'15''$  East a distance of 3188.03 feet to a set  $\frac{1}{2}$ " rebar with cap marked TX 5152 for a point of reverse curve;

Thence, 878.35 feet along the arc of a curve to the right, which has a radius of 1250.00 feet, a central angle of  $40^{\circ}15'38''$ , a chord which bears South  $02^{\circ}23'56''$  East a distance of 860.39 feet to a set  $\frac{1}{2}$ " rebar with cap marked TX 5152;

Thence, South  $17^{\circ}43'53''$  West a distance of 621.01 feet to a set  $\frac{1}{2}$ " rebar with cap marked TX 5152;

Thence, North  $72^{\circ}16'07''$  West a distance of 1226.61 feet to the "TRUE POINT OF BEGINNING" and containing 10,133,777 square feet or 232.64 acres of land more or less.

NOTE: A drawings of even date accompanies this description.

  
Ron R. Conde  
R.P.L.S. No. 5152  
Job# 621-10



CONDE, INC.  
ENGINEERING / LAND SURVEYING / PLANNING  
6080 SURETY DRIVE SUITE 100 / EL PASO, TEXAS 79936 / (915) 592-0283 FAX (915) 592-0286  
FIRM NO. 10078100

Prepared for: Southwest Land Development Services  
August 9, 2021. (Parcel II)

#### METES AND BOUNDS DESCRIPTION

Description of a parcel of land being a portion of Tracts 9B, 9B1, and 9B2, Laura E. Mundy Survey No. 238; and portion of lots 2 thru 5, 9 thru 12, and 21 thru 24, block 23, Enchanted Hills 5 as described in deed recorded in Clerks File No. 20210037543, Real property records of El Paso County, Texas, and being more particularly described by metes and bounds as follows:

Commencing for reference at a City of El Paso brass disk monument at the centerline intersection of Enchanted Path Drive and Enchanted Circle Dr., as shown on plat of Enchanted Hills Unit Three recorded in Clerks File No. 20210037543, Real Property Records of El Paso County, Texas, from which an existing brass disk City monument at the centerline intersection of Enchanted Pass Drive and Enchanted Park Drive bears, North 04°47'05" East a distance of 595.27 feet; Thence North 04°22'16" East a distance of 832.62 feet to a set ½" rebar with cap marked TX 5152 for THE "TRUE POINT OF BEGINNING";

Thence, North 03°12'50" East a distance of 15.00 feet to a set ½" rebar with cap marked TX 5152 for a point of curve;

Thence 139.90 feet along the arc of a curve to the right, which has a radius of 500.00 feet, a central angle of 16°01'53", a chord which bears North 11°13'46" East a distance of 139.44 feet to a set ½" rebar with cap marked TX 5152;

Thence 111.92 feet along the arc of a curve to the left, which has a radius of 400.00 feet, a central angle of 16°01'53", a chord which bears North 11°13'46" East a distance of 111.55 feet to a set ½" rebar with cap marked TX 5152;

Thence, North 03°12'50" East a distance of 216.72 feet to a set ½" rebar with cap marked TX 5152;

Thence 118.57 feet along the arc of a curve to the right, which has a radius of 400.00 feet, a central angle of 16°59'02", a chord which bears North 11°42'21" East a distance of 118.14 feet to a set ½" rebar with cap marked TX 5152;

Thence 9.57 feet along the arc of a curve to the left, which has a radius of 500.00 feet, a central angle of 01°05'48", a chord which bears North 19°38'58" East a distance of 9.57 feet to a point on the southerly right of way line on Hunter Foster Dr. as referenced on plat of Enchanted Hills Five recorded in Clerks File No. 20210037543, Real property records of El Paso County, Texas;

Thence along said right of way line the following 3 courses:

20.19 feet along the arc of a curve to the left, which has a radius of 1358.00 feet, a central angle of 00°51'07", a chord which bears South 67°16'16" East a distance of 20.16 feet to a set ½" rebar with cap marked TX 5152;

**CONDE, INC.**  
**ENGINEERING / LAND SURVEYING / PLANNING**  
**6080 SURETY DRIVE SUITE 100 / EL PASO, TEXAS 79936 / (915) 592-0283 FAX (915) 592-0286**  
**FIRM NO. 10078100**

598.55 feet along the arc of a curve to the left, which has a radius of 1358.00 feet, a central angle of  $25^{\circ}15'13''$ , a chord which bears South  $80^{\circ}19'26''$  East a distance of 593.72 feet to a set  $\frac{1}{2}$ " rebar with cap marked TX 5152;

450.82 feet along the arc of a curve to the right, which has a radius of 1292.00 feet, a central angle of  $19^{\circ}59'33''$ , a chord which bears South  $82^{\circ}57'16''$  East a distance of 448.54 feet to a set  $\frac{1}{2}$ " rebar with cap marked TX 5152;

Thence leaving said right of way line and along the westerly line of Block 23, Enchanted Hills Unit Five, South  $14^{\circ}04'05''$  West a distance of 195.56 feet to a set  $\frac{1}{2}$ " rebar with cap marked TX 5152;

Thence along said line, South  $03^{\circ}12'50''$  West a distance of 310.68 feet to a set  $\frac{1}{2}$ " rebar with cap marked TX 5152;

Thence along said line, South  $06^{\circ}33'45''$  West a distance of 103.69 feet to a set  $\frac{1}{2}$ " rebar with cap marked TX 5152;

Thence leaving said line, North  $81^{\circ}07'01''$  West a distance of 1047.91 feet to a point;

Thence, North  $86^{\circ}47'10''$  West a distance of 26.00 feet to the "TRUE POINT OF BEGINNING" and containing 625,722.06 square feet or 14.365 acres of land more or less.

NOTE: A drawings of even date accompanies this description.

  
Ron R. Conde  
R.P.L.S. No. 5152  
Job# 621-10



CONDE, INC.  
ENGINEERING / LAND SURVEYING / PLANNING  
6080 SURETY DRIVE SUITE 100 / EL PASO, TEXAS 79936 / (915) 592-0283 FAX (915) 592-0286  
FIRM NO. 10078100



Prepared for: Southwest Land Development Services  
August 9, 2021. (Parcel III)

### METES AND BOUNDS DESCRIPTION

Description of a parcel of land being a portion of Tract 9B2, Laura E. Mundy Survey No. 238, City of El Paso, el Paso County, Texas, and being more particularly described by metes and bounds as follows:

Commencing for reference at a City of El Paso brass disk monument at the centerline intersection of Enchanted Path Drive and Enchanted Circle Dr., as shown on plat of Enchanted Hills Unit Three recorded in Clerks File No. 20210037543, Real Property Records of El Paso County, Texas, from which an existing brass disk City monument at the centerline intersection of Enchanted Pass Drive and Enchanted Park Drive bears, North 04°47'05" East a distance of 595.27 feet; Thence North 04°22'16" East a distance of 832.62 feet to a set ½" rebar with cap marked TX 5152 for THE "TRUE POINT OF BEGINNING";

Thence, North 86°47'10" West a distance of 551.09 feet to a point on the westerly right of way line of U.S. Interstate Highway No. 10;

Thence along said right of way line, North 03°14'26" East a distance of 310.68 feet to a point;

Thence leaving said right of way line, South 86°47'10" East a distance of 585.95 feet to a set ½" rebar with cap marked TX 5152;

Thence, South 03°12'50" West a distance of 47.13 feet to a set ½" rebar with cap marked TX 5152 for a point of curve;

Thence 111.92 feet along the arc of a curve to the right, which has a radius of 400.00 feet, a central angle of 16°01'53", a chord which bears South 11°13'46" West a distance of 111.55 feet to a set ½" rebar with cap marked TX 5152;

Thence 139.90 feet along the arc of a curve to the left, which has a radius of 500.00 feet, a central angle of 16°01'53", a chord which bears South 11°13'46" West a distance of 139.44 feet to a set ½" rebar with cap marked TX 5152;

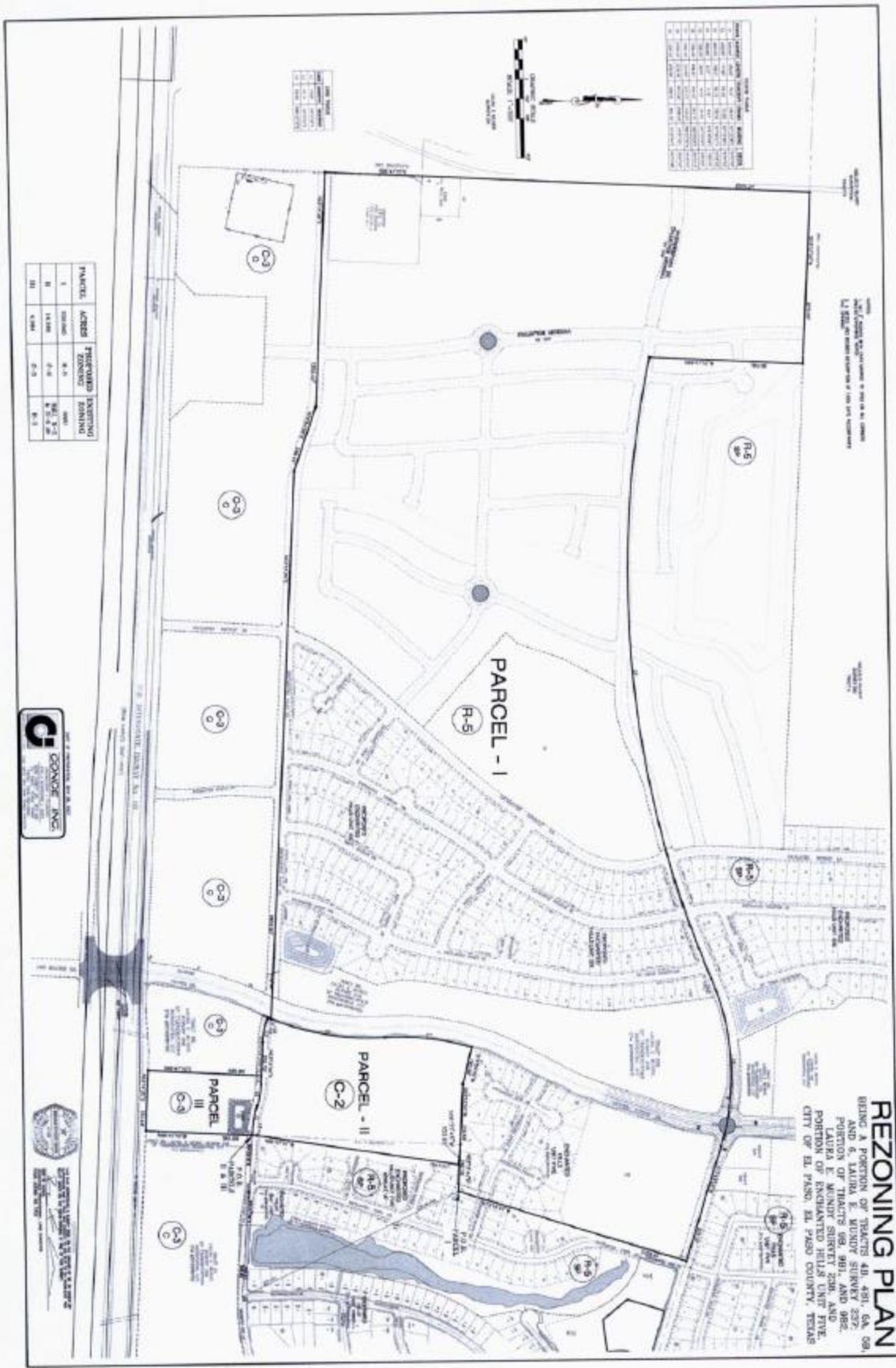
Thence, South 03°12'50" West a distance of 15.00 feet to the "TRUE POINT OF BEGINNING" and containing 177,026.93 square feet or 4.064 acres of land more or less.

NOTE: A drawings of even date accompanies this description.

  
Ron R. Conde  
R.P.L.S. No. 5152  
Job# 621-10



**CONDE, INC.**  
ENGINEERING / LAND SURVEYING / PLANNING  
6080 SURETY DRIVE SUITE 100 / EL PASO, TEXAS 79936 / (915) 592-0283 FAX (915) 592-0286  
FIRM NO. 10078100



**REZONING PLAN**  
 BEING A PORTION OF TRACTS 411, 451, 61A, 68,  
 AND 6, LAJUNIA E. ROUND STREET, 329,  
 PORTION OF TRACTS 58, 59, 60, AND 61,  
 AND A PORTION OF ENCHANTED HILLS UNIT FIVE,  
 CITY OF EL PASO, EL PASO COUNTY, TEXAS

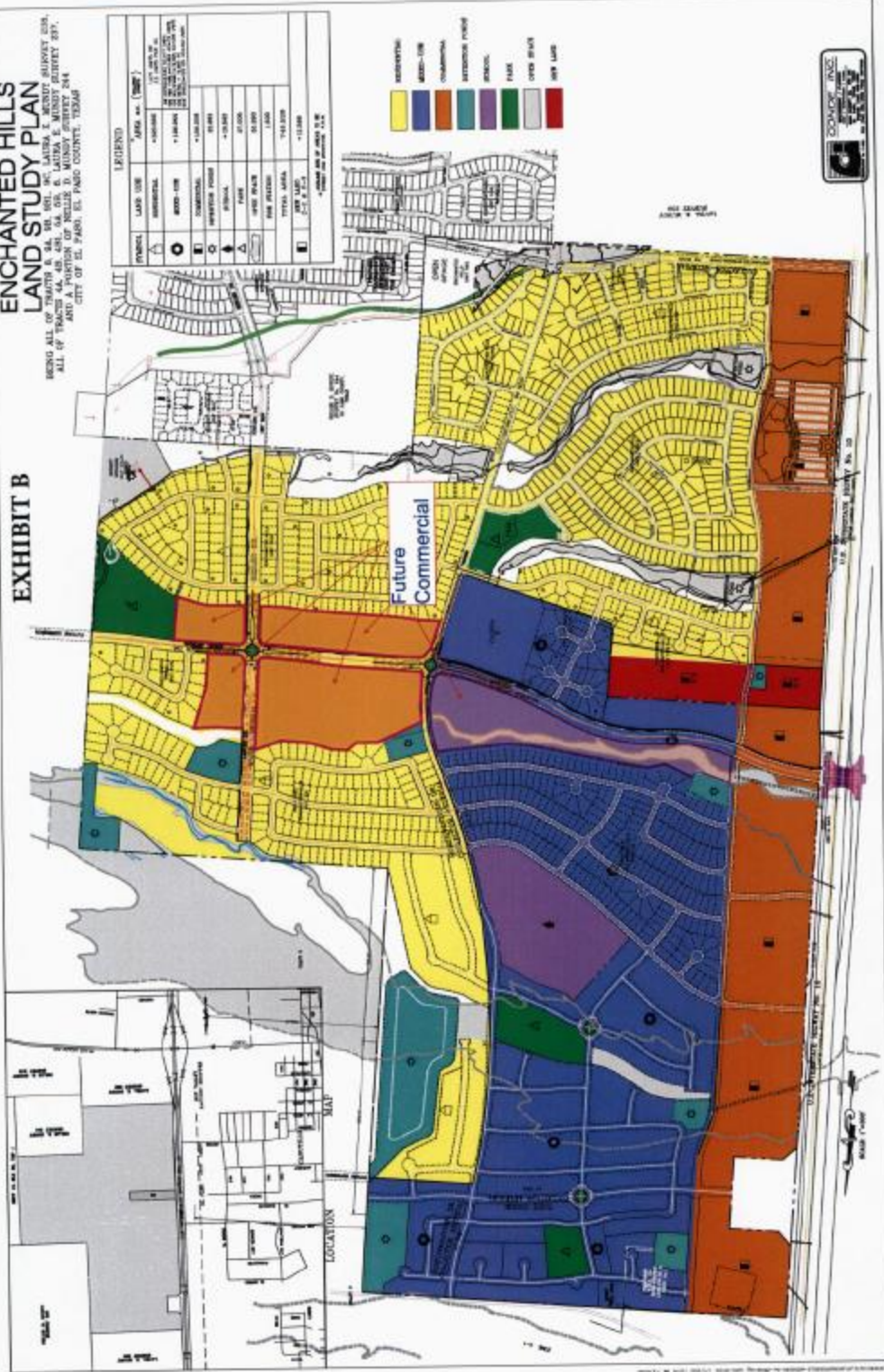




# ENCHANTED HILLS LAND STUDY PLAN

BEING ALL OF TRACTS 8, 9A, 9B, 9C, 9D, 9E, 9F, 9G, 9H, 9I, 9J, 9K, 9L, 9M, 9N, 9O, 9P, 9Q, 9R, 9S, 9T, 9U, 9V, 9W, 9X, 9Y, 9Z, 10A, 10B, 10C, 10D, 10E, 10F, 10G, 10H, 10I, 10J, 10K, 10L, 10M, 10N, 10O, 10P, 10Q, 10R, 10S, 10T, 10U, 10V, 10W, 10X, 10Y, 10Z, 11A, 11B, 11C, 11D, 11E, 11F, 11G, 11H, 11I, 11J, 11K, 11L, 11M, 11N, 11O, 11P, 11Q, 11R, 11S, 11T, 11U, 11V, 11W, 11X, 11Y, 11Z, 12A, 12B, 12C, 12D, 12E, 12F, 12G, 12H, 12I, 12J, 12K, 12L, 12M, 12N, 12O, 12P, 12Q, 12R, 12S, 12T, 12U, 12V, 12W, 12X, 12Y, 12Z, 13A, 13B, 13C, 13D, 13E, 13F, 13G, 13H, 13I, 13J, 13K, 13L, 13M, 13N, 13O, 13P, 13Q, 13R, 13S, 13T, 13U, 13V, 13W, 13X, 13Y, 13Z, 14A, 14B, 14C, 14D, 14E, 14F, 14G, 14H, 14I, 14J, 14K, 14L, 14M, 14N, 14O, 14P, 14Q, 14R, 14S, 14T, 14U, 14V, 14W, 14X, 14Y, 14Z, 15A, 15B, 15C, 15D, 15E, 15F, 15G, 15H, 15I, 15J, 15K, 15L, 15M, 15N, 15O, 15P, 15Q, 15R, 15S, 15T, 15U, 15V, 15W, 15X, 15Y, 15Z, 16A, 16B, 16C, 16D, 16E, 16F, 16G, 16H, 16I, 16J, 16K, 16L, 16M, 16N, 16O, 16P, 16Q, 16R, 16S, 16T, 16U, 16V, 16W, 16X, 16Y, 16Z, 17A, 17B, 17C, 17D, 17E, 17F, 17G, 17H, 17I, 17J, 17K, 17L, 17M, 17N, 17O, 17P, 17Q, 17R, 17S, 17T, 17U, 17V, 17W, 17X, 17Y, 17Z, 18A, 18B, 18C, 18D, 18E, 18F, 18G, 18H, 18I, 18J, 18K, 18L, 18M, 18N, 18O, 18P, 18Q, 18R, 18S, 18T, 18U, 18V, 18W, 18X, 18Y, 18Z, 19A, 19B, 19C, 19D, 19E, 19F, 19G, 19H, 19I, 19J, 19K, 19L, 19M, 19N, 19O, 19P, 19Q, 19R, 19S, 19T, 19U, 19V, 19W, 19X, 19Y, 19Z, 20A, 20B, 20C, 20D, 20E, 20F, 20G, 20H, 20I, 20J, 20K, 20L, 20M, 20N, 20O, 20P, 20Q, 20R, 20S, 20T, 20U, 20V, 20W, 20X, 20Y, 20Z, 21A, 21B, 21C, 21D, 21E, 21F, 21G, 21H, 21I, 21J, 21K, 21L, 21M, 21N, 21O, 21P, 21Q, 21R, 21S, 21T, 21U, 21V, 21W, 21X, 21Y, 21Z, 22A, 22B, 22C, 22D, 22E, 22F, 22G, 22H, 22I, 22J, 22K, 22L, 22M, 22N, 22O, 22P, 22Q, 22R, 22S, 22T, 22U, 22V, 22W, 22X, 22Y, 22Z, 23A, 23B, 23C, 23D, 23E, 23F, 23G, 23H, 23I, 23J, 23K, 23L, 23M, 23N, 23O, 23P, 23Q, 23R, 23S, 23T, 23U, 23V, 23W, 23X, 23Y, 23Z, 24A, 24B, 24C, 24D, 24E, 24F, 24G, 24H, 24I, 24J, 24K, 24L, 24M, 24N, 24O, 24P, 24Q, 24R, 24S, 24T, 24U, 24V, 24W, 24X, 24Y, 24Z, 25A, 25B, 25C, 25D, 25E, 25F, 25G, 25H, 25I, 25J, 25K, 25L, 25M, 25N, 25O, 25P, 25Q, 25R, 25S, 25T, 25U, 25V, 25W, 25X, 25Y, 25Z, 26A, 26B, 26C, 26D, 26E, 26F, 26G, 26H, 26I, 26J, 26K, 26L, 26M, 26N, 26O, 26P, 26Q, 26R, 26S, 26T, 26U, 26V, 26W, 26X, 26Y, 26Z, 27A, 27B, 27C, 27D, 27E, 27F, 27G, 27H, 27I, 27J, 27K, 27L, 27M, 27N, 27O, 27P, 27Q, 27R, 27S, 27T, 27U, 27V, 27W, 27X, 27Y, 27Z, 28A, 28B, 28C, 28D, 28E, 28F, 28G, 28H, 28I, 28J, 28K, 28L, 28M, 28N, 28O, 28P, 28Q, 28R, 28S, 28T, 28U, 28V, 28W, 28X, 28Y, 28Z, 29A, 29B, 29C, 29D, 29E, 29F, 29G, 29H, 29I, 29J, 29K, 29L, 29M, 29N, 29O, 29P, 29Q, 29R, 29S, 29T, 29U, 29V, 29W, 29X, 29Y, 29Z, 30A, 30B, 30C, 30D, 30E, 30F, 30G, 30H, 30I, 30J, 30K, 30L, 30M, 30N, 30O, 30P, 30Q, 30R, 30S, 30T, 30U, 30V, 30W, 30X, 30Y, 30Z, 31A, 31B, 31C, 31D, 31E, 31F, 31G, 31H, 31I, 31J, 31K, 31L, 31M, 31N, 31O, 31P, 31Q, 31R, 31S, 31T, 31U, 31V, 31W, 31X, 31Y, 31Z, 32A, 32B, 32C, 32D, 32E, 32F, 32G, 32H, 32I, 32J, 32K, 32L, 32M, 32N, 32O, 32P, 32Q, 32R, 32S, 32T, 32U, 32V, 32W, 32X, 32Y, 32Z, 33A, 33B, 33C, 33D, 33E, 33F, 33G, 33H, 33I, 33J, 33K, 33L, 33M, 33N, 33O, 33P, 33Q, 33R, 33S, 33T, 33U, 33V, 33W, 33X, 33Y, 33Z, 34A, 34B, 34C, 34D, 34E, 34F, 34G, 34H, 34I, 34J, 34K, 34L, 34M, 34N, 34O, 34P, 34Q, 34R, 34S, 34T, 34U, 34V, 34W, 34X, 34Y, 34Z, 35A, 35B, 35C, 35D, 35E, 35F, 35G, 35H, 35I, 35J, 35K, 35L, 35M, 35N, 35O, 35P, 35Q, 35R, 35S, 35T, 35U, 35V, 35W, 35X, 35Y, 35Z, 36A, 36B, 36C, 36D, 36E, 36F, 36G, 36H, 36I, 36J, 36K, 36L, 36M, 36N, 36O, 36P, 36Q, 36R, 36S, 36T, 36U, 36V, 36W, 36X, 36Y, 36Z, 37A, 37B, 37C, 37D, 37E, 37F, 37G, 37H, 37I, 37J, 37K, 37L, 37M, 37N, 37O, 37P, 37Q, 37R, 37S, 37T, 37U, 37V, 37W, 37X, 37Y, 37Z, 38A, 38B, 38C, 38D, 38E, 38F, 38G, 38H, 38I, 38J, 38K, 38L, 38M, 38N, 38O, 38P, 38Q, 38R, 38S, 38T, 38U, 38V, 38W, 38X, 38Y, 38Z, 39A, 39B, 39C, 39D, 39E, 39F, 39G, 39H, 39I, 39J, 39K, 39L, 39M, 39N, 39O, 39P, 39Q, 39R, 39S, 39T, 39U, 39V, 39W, 39X, 39Y, 39Z, 40A, 40B, 40C, 40D, 40E, 40F, 40G, 40H, 40I, 40J, 40K, 40L, 40M, 40N, 40O, 40P, 40Q, 40R, 40S, 40T, 40U, 40V, 40W, 40X, 40Y, 40Z, 41A, 41B, 41C, 41D, 41E, 41F, 41G, 41H, 41I, 41J, 41K, 41L, 41M, 41N, 41O, 41P, 41Q, 41R, 41S, 41T, 41U, 41V, 41W, 41X, 41Y, 41Z, 42A, 42B, 42C, 42D, 42E, 42F, 42G, 42H, 42I, 42J, 42K, 42L, 42M, 42N, 42O, 42P, 42Q, 42R, 42S, 42T, 42U, 42V, 42W, 42X, 42Y, 42Z, 43A, 43B, 43C, 43D, 43E, 43F, 43G, 43H, 43I, 43J, 43K, 43L, 43M, 43N, 43O, 43P, 43Q, 43R, 43S, 43T, 43U, 43V, 43W, 43X, 43Y, 43Z, 44A, 44B, 44C, 44D, 44E, 44F, 44G, 44H, 44I, 44J, 44K, 44L, 44M, 44N, 44O, 44P, 44Q, 44R, 44S, 44T, 44U, 44V, 44W, 44X, 44Y, 44Z, 45A, 45B, 45C, 45D, 45E, 45F, 45G, 45H, 45I, 45J, 45K, 45L, 45M, 45N, 45O, 45P, 45Q, 45R, 45S, 45T, 45U, 45V, 45W, 45X, 45Y, 45Z, 46A, 46B, 46C, 46D, 46E, 46F, 46G, 46H, 46I, 46J, 46K, 46L, 46M, 46N, 46O, 46P, 46Q, 46R, 46S, 46T, 46U, 46V, 46W, 46X, 46Y, 46Z, 47A, 47B, 47C, 47D, 47E, 47F, 47G, 47H, 47I, 47J, 47K, 47L, 47M, 47N, 47O, 47P, 47Q, 47R, 47S, 47T, 47U, 47V, 47W, 47X, 47Y, 47Z, 48A, 48B, 48C, 48D, 48E, 48F, 48G, 48H, 48I, 48J, 48K, 48L, 48M, 48N, 48O, 48P, 48Q, 48R, 48S, 48T, 48U, 48V, 48W, 48X, 48Y, 48Z, 49A, 49B, 49C, 49D, 49E, 49F, 49G, 49H, 49I, 49J, 49K, 49L, 49M, 49N, 49O, 49P, 49Q, 49R, 49S, 49T, 49U, 49V, 49W, 49X, 49Y, 49Z, 50A, 50B, 50C, 50D, 50E, 50F, 50G, 50H, 50I, 50J, 50K, 50L, 50M, 50N, 50O, 50P, 50Q, 50R, 50S, 50T, 50U, 50V, 50W, 50X, 50Y, 50Z, 51A, 51B, 51C, 51D, 51E, 51F, 51G, 51H, 51I, 51J, 51K, 51L, 51M, 51N, 51O, 51P, 51Q, 51R, 51S, 51T, 51U, 51V, 51W, 51X, 51Y, 51Z, 52A, 52B, 52C, 52D, 52E, 52F, 52G, 52H, 52I, 52J, 52K, 52L, 52M, 52N, 52O, 52P, 52Q, 52R, 52S, 52T, 52U, 52V, 52W, 52X, 52Y, 52Z, 53A, 53B, 53C, 53D, 53E, 53F, 53G, 53H, 53I, 53J, 53K, 53L, 53M, 53N, 53O, 53P, 53Q, 53R, 53S, 53T, 53U, 53V, 53W, 53X, 53Y, 53Z, 54A, 54B, 54C, 54D, 54E, 54F, 54G, 54H, 54I, 54J, 54K, 54L, 54M, 54N, 54O, 54P, 54Q, 54R, 54S, 54T, 54U, 54V, 54W, 54X, 54Y, 54Z, 55A, 55B, 55C, 55D, 55E, 55F, 55G, 55H, 55I, 55J, 55K, 55L, 55M, 55N, 55O, 55P, 55Q, 55R, 55S, 55T, 55U, 55V, 55W, 55X, 55Y, 55Z, 56A, 56B, 56C, 56D, 56E, 56F, 56G, 56H, 56I, 56J, 56K, 56L, 56M, 56N, 56O, 56P, 56Q, 56R, 56S, 56T, 56U, 56V, 56W, 56X, 56Y, 56Z, 57A, 57B, 57C, 57D, 57E, 57F, 57G, 57H, 57I, 57J, 57K, 57L, 57M, 57N, 57O, 57P, 57Q, 57R, 57S, 57T, 57U, 57V, 57W, 57X, 57Y, 57Z, 58A, 58B, 58C, 58D, 58E, 58F, 58G, 58H, 58I, 58J, 58K, 58L, 58M, 58N, 58O, 58P, 58Q, 58R, 58S, 58T, 58U, 58V, 58W, 58X, 58Y, 58Z, 59A, 59B, 59C, 59D, 59E, 59F, 59G, 59H, 59I, 59J, 59K, 59L, 59M, 59N, 59O, 59P, 59Q, 59R, 59S, 59T, 59U, 59V, 59W, 59X, 59Y, 59Z, 60A, 60B, 60C, 60D, 60E, 60F, 60G, 60H, 60I, 60J, 60K, 60L, 60M, 60N, 60O, 60P, 60Q, 60R, 60S, 60T, 60U, 60V, 60W, 60X, 60Y, 60Z, 61A, 61B, 61C, 61D, 61E, 61F, 61G, 61H, 61I, 61J, 61K, 61L, 61M, 61N, 61O, 61P, 61Q, 61R, 61S, 61T, 61U, 61V, 61W, 61X, 61Y, 61Z, 62A, 62B, 62C, 62D, 62E, 62F, 62G, 62H, 62I, 62J, 62K, 62L, 62M, 62N, 62O, 62P, 62Q, 62R, 62S, 62T, 62U, 62V, 62W, 62X, 62Y, 62Z, 63A, 63B, 63C, 63D, 63E, 63F, 63G, 63H, 63I, 63J, 63K, 63L, 63M, 63N, 63O, 63P, 63Q, 63R, 63S, 63T, 63U, 63V, 63W, 63X, 63Y, 63Z, 64A, 64B, 64C, 64D, 64E, 64F, 64G, 64H, 64I, 64J, 64K, 64L, 64M, 64N, 64O, 64P, 64Q, 64R, 64S, 64T, 64U, 64V, 64W, 64X, 64Y, 64Z, 65A, 65B, 65C, 65D, 65E, 65F, 65G, 65H, 65I, 65J, 65K, 65L, 65M, 65N, 65O, 65P, 65Q, 65R, 65S, 65T, 65U, 65V, 65W, 65X, 65Y, 65Z, 66A, 66B, 66C, 66D, 66E, 66F, 66G, 66H, 66I, 66J, 66K, 66L, 66M, 66N, 66O, 66P, 66Q, 66R, 66S, 66T, 66U, 66V, 66W, 66X, 66Y, 66Z, 67A, 67B, 67C, 67D, 67E, 67F, 67G, 67H, 67I, 67J, 67K, 67L, 67M, 67N, 67O, 67P, 67Q, 67R, 67S, 67T, 67U, 67V, 67W, 67X, 67Y, 67Z, 68A, 68B, 68C, 68D, 68E, 68F, 68G, 68H, 68I, 68J, 68K, 68L, 68M, 68N, 68O, 68P, 68Q, 68R, 68S, 68T, 68U, 68V, 68W, 68X, 68Y, 68Z, 69A, 69B, 69C, 69D, 69E, 69F, 69G, 69H, 69I, 69J, 69K, 69L, 69M, 69N, 69O, 69P, 69Q, 69R, 69S, 69T, 69U, 69V, 69W, 69X, 69Y, 69Z, 70A, 70B, 70C, 70D, 70E, 70F, 70G, 70H, 70I, 70J, 70K, 70L, 70M, 70N, 70O, 70P, 70Q, 70R, 70S, 70T, 70U, 70V, 70W, 70X, 70Y, 70Z, 71A, 71B, 71C, 71D, 71E, 71F, 71G, 71H, 71I, 71J, 71K, 71L, 71M, 71N, 71O, 71P, 71Q, 71R, 71S, 71T, 71U, 71V, 71W, 71X, 71Y, 71Z, 72A, 72B, 72C, 72D, 72E, 72F, 72G, 72H, 72I, 72J, 72K, 72L, 72M, 72N, 72O, 72P, 72Q, 72R, 72S, 72T, 72U, 72V, 72W, 72X, 72Y, 72Z, 73A, 73B, 73C, 73D, 73E, 73F, 73G, 73H, 73I, 73J, 73K, 73L, 73M, 73N, 73O, 73P, 73Q, 73R, 73S, 73T, 73U, 73V, 73W, 73X, 73Y, 73Z, 74A, 74B, 74C, 74D, 74E, 74F, 74G, 74H, 74I, 74J, 74K, 74L, 74M, 74N, 74O, 74P, 74Q, 74R, 74S, 74T, 74U, 74V, 74W, 74X, 74Y, 74Z, 75A, 75B, 75C, 75D, 75E, 75F, 75G, 75H, 75I, 75J, 75K, 75L, 75M, 75N, 75O, 75P, 75Q, 75R, 75S, 75T, 75U, 75V, 75W, 75X, 75Y, 75Z, 76A, 76B, 76C, 76D, 76E, 76F, 76G, 76H, 76I, 76J, 76K, 76L, 76M, 76N, 76O, 76P, 76Q, 76R, 76S, 76T, 76U, 76V, 76W, 76X, 76Y, 76Z, 77A, 77B, 77C, 77D, 77E, 77F, 77G, 77H, 77I, 77J, 77K, 77L, 77M, 77N, 77O, 77P, 77Q, 77R, 77S, 77T, 77U, 77V, 77W, 77X, 77Y, 77Z, 78A, 78B, 78C, 78D, 78E, 78F, 78G, 78H, 78I, 78J, 78K, 78L, 78M, 78N, 78O, 78P, 78Q, 78R, 78S, 78T, 78U, 78V, 78W, 78X, 78Y, 78Z, 79A, 79B, 79C, 79D, 79E, 79F, 79G, 79H, 79I, 79J, 79K, 79L, 79M, 79N, 79O, 79P, 79Q, 79R, 79S, 79T, 79U, 79V, 79W, 79X, 79Y, 79Z, 80A, 80B, 80C, 80D, 80E, 80F, 80G, 80H, 80I, 80J, 80K, 80L, 80M, 80N, 80O, 80P, 80Q, 80R, 80S, 80T, 80U, 80V, 80W, 80X, 80Y, 80Z, 81A, 81B, 81C, 81D, 81E, 81F, 81G, 81H, 81I, 81J, 81K, 81L, 81M, 81N, 81O, 81P, 81Q, 81R, 81S, 81T, 81U, 81V, 81W, 81X, 81Y, 81Z, 82A, 82B, 82C, 82D, 82E, 82F, 82G, 82H, 82I, 82J, 82K, 82L, 82M, 82N, 82O, 82P, 82Q, 82R, 82S, 82T, 82U, 82V, 82W, 82X, 82Y, 82Z, 83A, 83B, 83C, 83D, 83E, 83F, 83G, 83H, 83I, 83J, 83K, 83L, 83M, 83N, 83O, 83P, 83Q, 83R, 83S, 83T, 83U, 83V, 83W, 83X, 83Y, 83Z, 84A, 84B, 84C, 84D, 84E, 84F, 84G, 84H, 84I, 84J, 84K, 84L, 84M, 84N, 84O, 84P, 84Q, 84R, 84S, 84T, 84U, 84V, 84W, 84X, 84Y, 84Z, 85A, 85B, 85C, 85D, 85E, 85F, 85G, 85H, 85I, 85J, 85K, 85L, 85M, 85N, 85O, 85P, 85Q, 85R, 85S, 85T, 85U, 85V, 85W, 85X, 85Y, 85Z, 86A, 86B, 86C, 86D, 86E, 86F, 86G, 86H, 86I, 86J, 86K, 86L, 86M, 86N, 86O, 86P, 86Q, 86R, 86S, 86T, 86U, 86V, 86W, 86X, 86Y, 86Z, 87A, 87B, 87C, 87D, 87E, 87F, 87G, 87H, 87I, 87J, 87K, 87L, 87M, 87N, 87O, 87P, 87Q, 87R, 87S, 87T, 87U, 87V, 87W, 87X, 87Y, 87Z, 88A, 88B, 88C, 88D, 88E, 88F, 88G, 88H, 88I, 88J, 88K, 88L, 88M, 88N, 88O, 88P, 88Q, 88R, 88S, 88T, 88U, 88V, 88W, 88X, 88Y, 88Z, 89A, 89B, 89C, 89D, 89E, 89F, 89G, 89H, 89I, 89J, 89K, 89L, 89M, 89N, 89O, 89P, 89Q, 89R, 89S, 89T, 89U, 89V, 89W, 89X, 89Y, 89Z, 90A, 90B, 90C, 90D, 90E, 90F, 90G, 90H, 90I, 90J, 90K, 90L, 90M, 90N, 90O, 90P, 90Q, 90R, 90S, 90T, 90U, 90V, 90W, 90X, 90Y, 90Z, 91A, 91B, 91C, 91D, 91E, 91F, 91G, 91H, 91I, 91J, 91K, 91L, 91M, 91N, 91O, 91P, 91Q, 91R, 91S, 91T, 91U, 91V, 91W, 91X, 91Y, 91Z, 92A, 92B, 92C, 92D, 92E, 92F, 92G, 92H, 92I, 92J, 92K, 92L, 92M, 92N, 92O, 92P, 92Q, 92R, 92S, 92T, 92U, 92V, 92W, 92X, 92Y, 92Z, 93A, 93B, 93C, 93D, 93E, 93F, 93G, 93H, 93I, 93J, 93K, 93L, 93M, 93N, 93O, 93P, 93Q, 93R, 93S, 93T, 93U, 93V, 93W, 93X, 93Y, 93Z, 94A, 94B, 94C, 94D, 94E, 94F, 94G, 94H, 94I, 94J, 94K, 94L, 94M, 94N, 94O, 94P, 94Q, 94R, 94S, 94T, 94U, 94V, 94W, 94X, 94Y, 94Z, 95A, 95B, 95C, 95D, 95E, 95F, 95G, 95H, 95I, 95J, 95K, 95L, 95M, 95N, 95O, 95P, 95Q, 95R, 95S, 95T, 95U, 95V, 95W, 95X, 95Y, 95Z, 96A, 96B, 96C, 96D, 96E, 96F, 96G, 96H, 96I, 96J, 96K, 96L, 96M, 96N, 96O, 96P, 96Q, 96R, 96S, 96T, 96U, 96V, 96W, 96X, 96Y, 96Z, 97A, 97B, 97C, 97D, 97E, 97F, 97G, 97H, 97I, 97J, 97K, 97L, 97M, 97N, 97O, 97P, 97Q, 97R, 97S, 97T, 97U, 97V, 97W, 97X, 97Y, 97Z, 98A, 98B, 98C, 98D, 98E, 98F, 98G, 98H, 98I, 98J, 98K, 98L, 98M, 98N, 98O, 98P, 98Q, 98R, 98S, 98T, 98U, 98V, 98W, 98X, 98Y, 98Z, 99A, 99B, 99C, 99D, 99E, 99F, 99G, 99H, 99I, 99J, 99K, 99L, 99M, 99N, 99O, 99P, 99Q, 99R, 99S, 99T, 99U, 99V, 99W, 99X, 99Y, 99Z, 100A, 100B, 100C, 100D, 100E, 100F, 100G, 100H, 100I, 100J, 100K, 100L, 100M, 100N, 100O, 100P, 100Q, 100R, 100S, 100T, 100U, 100V, 100W, 100X, 100Y, 100Z.

## EXHIBIT B







ITEM 26

# Northwestern, Resler, Hunter Foster Rezoning

PZRZ22-00009

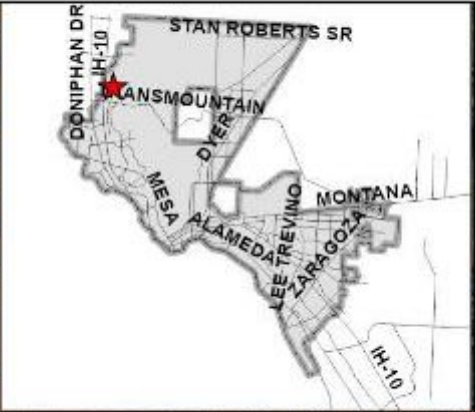
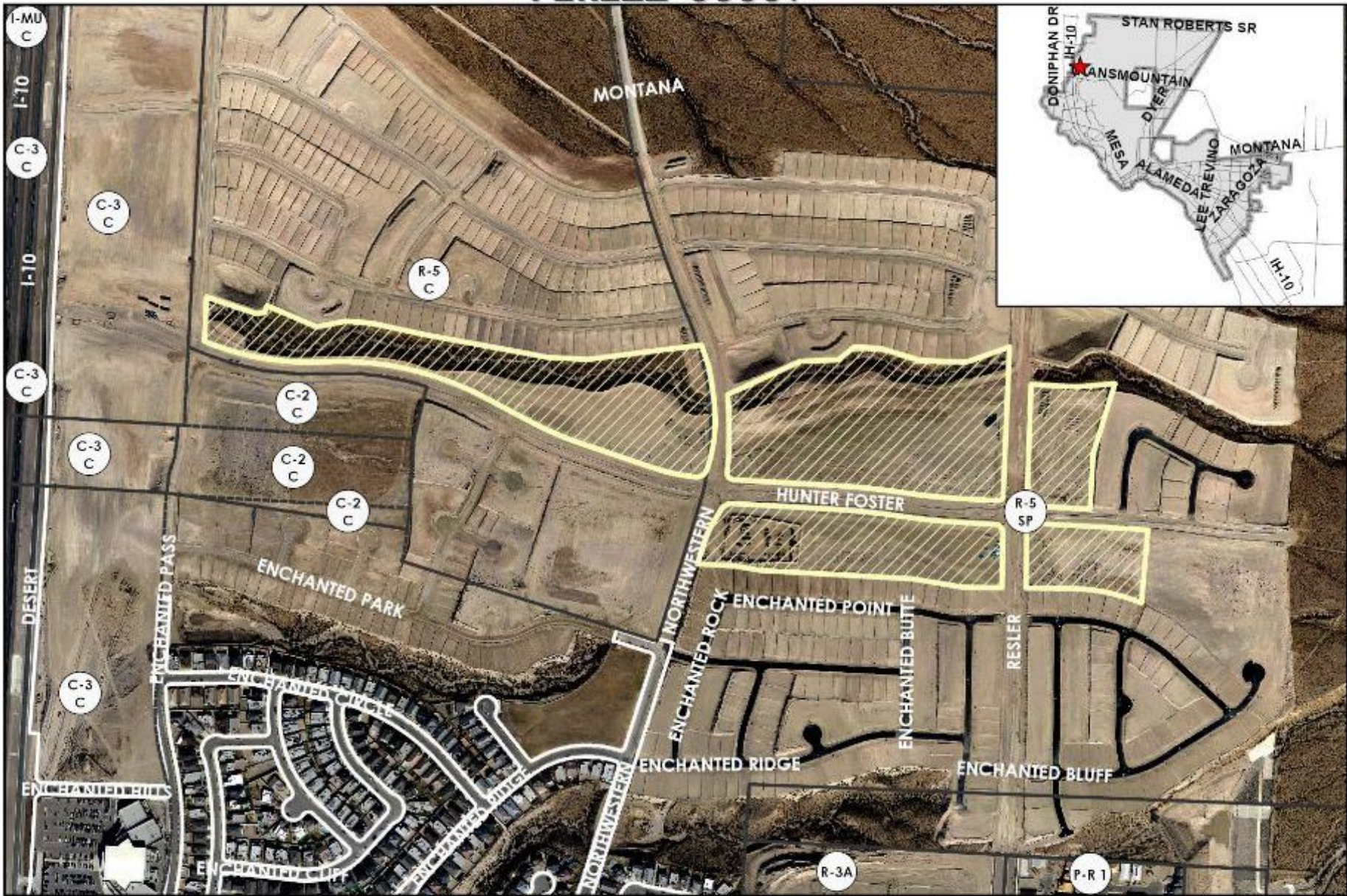


**Strategic Goal 3.**

Promote the Visual Image of  
El Paso



# Aerial



This map is designed for illustrative purposes only. The features depicted here are approximate and more site-specific studies may be required to create accurate conclusions. Engagement of this map to scales greater than its original can induce errors and may lead to misinterpretations of the data. The Planning & Inspection Department Planning Division makes no claim to its accuracy or completeness.

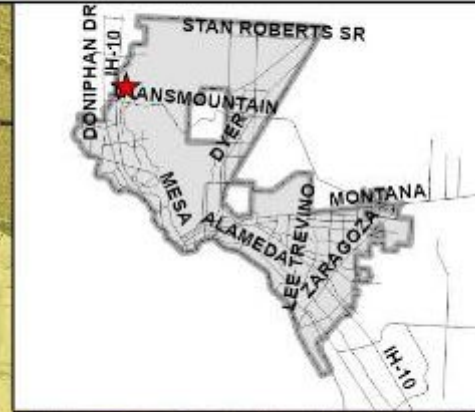
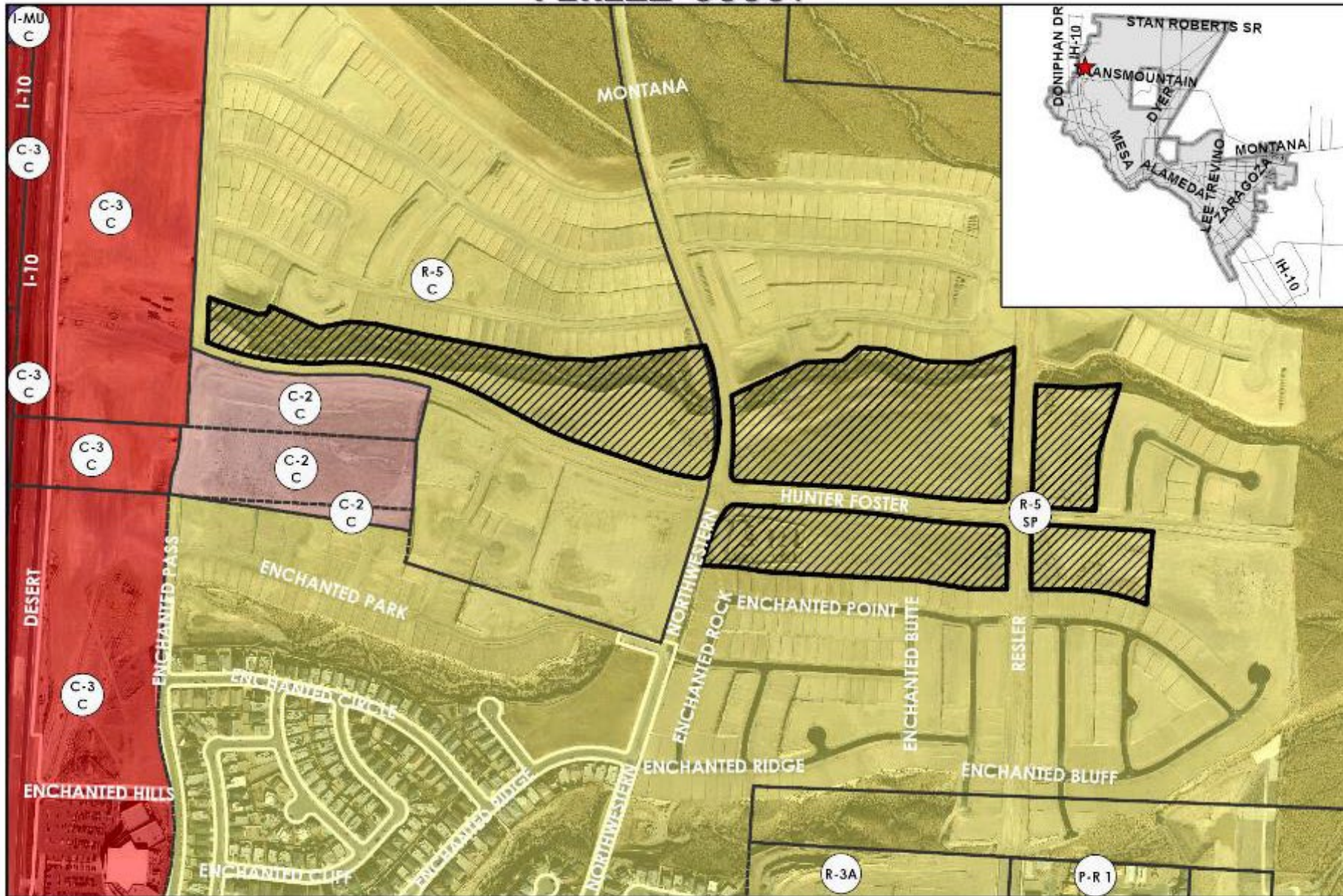


Subject Property





# Existing Zoning



This map is designed for illustrative purposes only. The features depicted here are approximate and more site-specific studies may be required to draw accurate conclusions. Engagement of this map to scales greater than its original can induce errors and may lead to misinterpretations of the data. The Planning & Inspection Department Planning Division makes no claim to its accuracy or completeness.



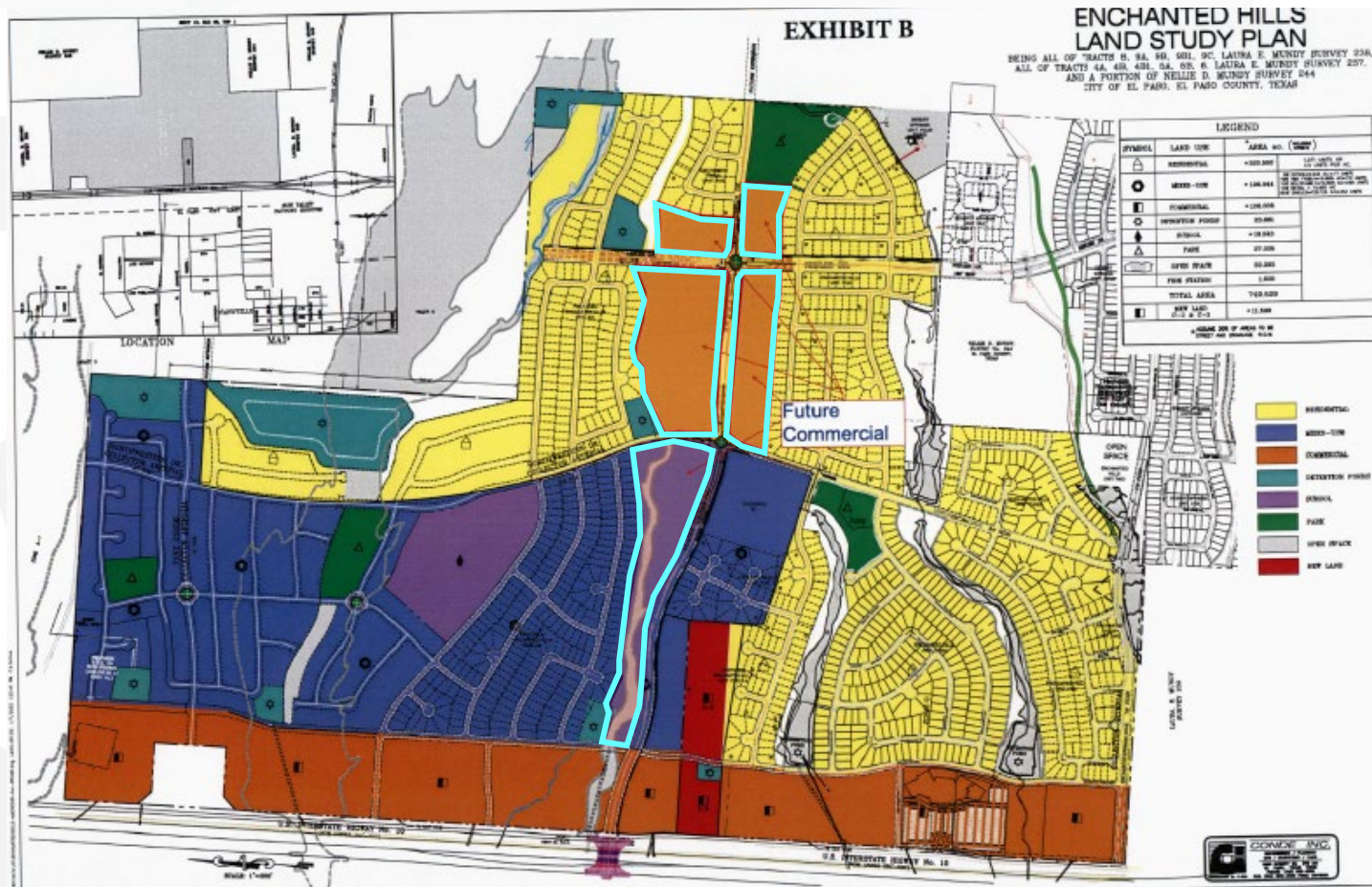
 Subject Property





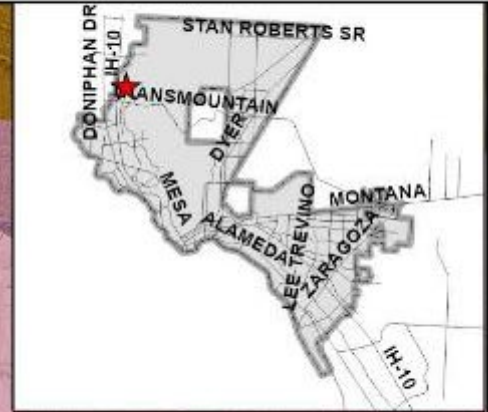
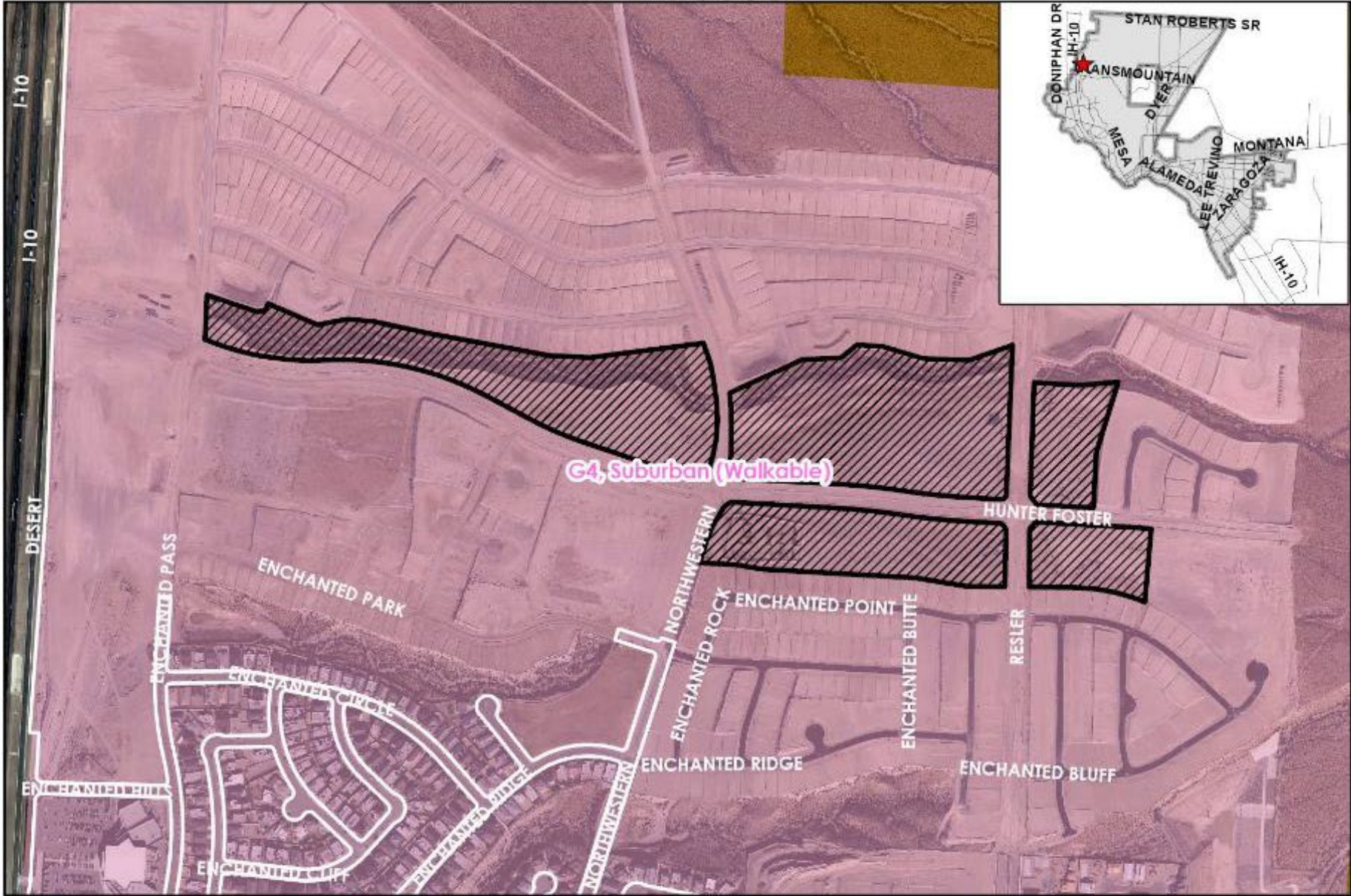
1. On Parcel 2, a ten-foot (10') landscaped buffer with high-profile native or naturalized trees of at least two-inch (2") caliper and ten feet (10') in height shall be placed at thirty feet (30') on center along the property lines adjacent to residential zone districts or uses. The landscaped buffer shall be irrigated and maintained by the property owner at all times and shall be installed prior to the issuance of any certificates of occupancy.
2. That a detailed site development plan shall be reviewed and approved per the El Paso City Code prior to the issuance of building permits for Parcel 2.
3. That a detailed site development plan shall be reviewed and approved per the El Paso City Code prior to the issuance of building permits for Parcel 3.
4. That prior to the issuance of certificates of occupancy for Parcel 1, 2, and 3, the rezonings for the properties identified as "future commercial" on Exhibit B be submitted and processed by the City.

# Condition No. 4





# Future Land Use



This map is designed for illustrative purposes only. The features depicted here are approximate and more site-specific studies may be required to create accurate conclusions. Engagement of this map to scales greater than its original can induce errors and may lead to misinterpretations of the data. The Planning & Inspection Department Planning Division makes no claim to its accuracy or completeness.

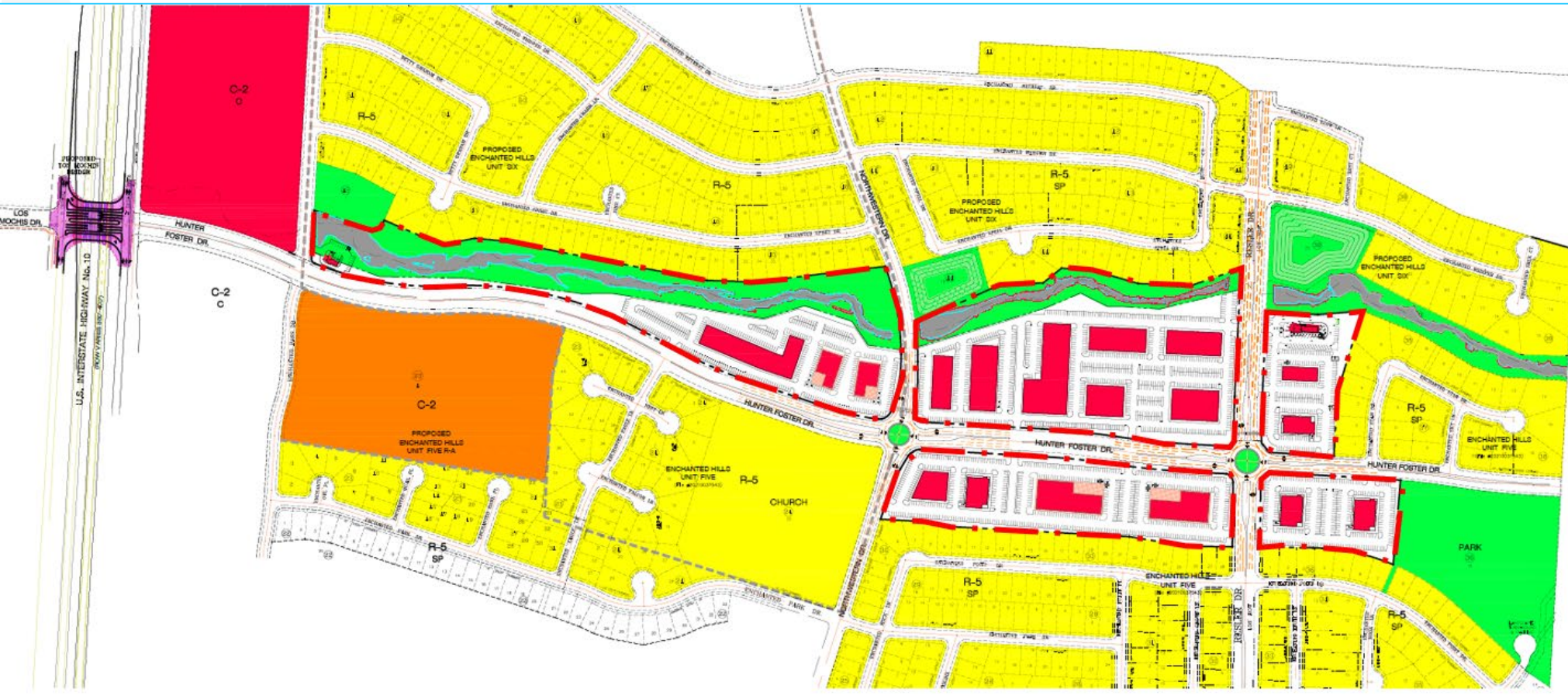


 Subject Property





# Conceptual Plan





# Subject Property





# Surrounding Development



N



W



S



# Public Input

- Notices were mailed to property owners within 300 feet on April 21, 2022.
- The Planning Division has not received any communications in support nor opposition to the request.



# Recommendation

- Staff, OSAB, and CPC recommended approval of the rezoning request with the following conditions:
  1. That a ten-foot (10') landscaped buffer with high-profile native or naturalized trees of at least two-inch (2") caliper and ten feet (10') in height shall be placed at twenty feet (20') on center along the property lines adjacent to residential zone districts or uses. The landscaped buffer shall be irrigated and maintained by the property owner at all times and shall be installed prior to the issuance of any certificates of occupancy.
    - a. This condition shall not apply where the existing arroyo will serve as a natural buffer between the subject properties and residential zone districts or uses.
    - b. The landscaping required under this condition will count towards the landscaping required under Title 18.
  2. That a detailed site development plan shall be reviewed and approved per the El Paso City Code prior to the issuance of building permits.
  3. That a minimum 500-foot distance be required between any establishments meeting both of the following criteria:
    - a. Establishment deriving 51% or more of their income from the sale of alcoholic beverages for on-premise consumption; and
    - b. Providing outdoor amplified sound.



## Mission

Deliver exceptional services to support a high quality of life and place for our community



## Vision

Develop a vibrant regional economy, safe and beautiful neighborhoods and exceptional recreational, cultural and educational opportunities powered by a high performing government



## Values

Integrity, Respect, Excellence, Accountability, People



---

File #: 22-848, Version: 1

---

**CITY OF EL PASO, TEXAS  
LEGISTAR AGENDA ITEM SUMMARY FORM**

**DISTRICT, DEPARTMENT, CONTACT INFORMATION:**

*Please choose District and Department from drop down menu. Please post exactly as example below.  
No Title's, No emails. Please use ARIAL 10 Font.*

**District 4**

Planning and Inspections, Philip F. Etiwe, (915) 212-1553  
Planning and Inspections, Nina Rodriguez, (915) 212-1561

**AGENDA LANGUAGE:**

*This is the language that will be posted to the agenda. Please use ARIAL 11 Font.*

An Ordinance changing the zoning of a portion of the East 300 feet of North 150 feet of South 165 feet of Tract 9-D, First Supplemental Map of Parkland Addition, City of El Paso, El Paso County, Texas from R-4 (Residential) to A-O (Apartment/Office) and imposing conditions. The penalty is as provided for in Chapter 20.24 of the El Paso City Code.

The proposed rezoning meets the intent of the Future Land Use designation for the property and is in accordance with Plan El Paso, the City's Comprehensive Plan.

Subject Property: North of Woodrow Bean Transmountain Drive and East of Bomarc Street  
Applicant: CEA Group, PZRZ22-00015

**CITY OF EL PASO, TEXAS  
AGENDA ITEM  
DEPARTMENT HEAD'S SUMMARY FORM**

**AGENDA DATE:** July 6, 2022  
**PUBLIC HEARING DATE:** August 2, 2022

**CONTACT PERSON(S) NAME AND PHONE NUMBER:** Philip F. Etiwe, (915) 212-1553  
Nina Rodriguez, (915) 212-1561

**DISTRICT(S) AFFECTED:** District 4

**STRATEGIC GOAL:** #3 Promote the Visual Image of El Paso

**SUBGOAL:** 3.2 Set one standard for infrastructure across the city

**SUBJECT:**

An Ordinance changing the zoning of a portion of the East 300 feet of North 150 feet of South 165 feet of Tract 9-D, First Supplemental Map of Parkland Addition, City of El Paso, El Paso County, Texas from R-4 (Residential) to A-O (Apartment/Office) and imposing conditions. The penalty is as provided for in Chapter 20.24 of the El Paso City Code.

The proposed rezoning meets the intent of the Future Land Use designation for the property and is in accordance with *Plan El Paso*, the City's Comprehensive Plan.

Subject Property: North of Woodrow Bean Transmountain Drive and East of Bomarc Street  
Applicant: CEA Group, PZRZ22-00015

**BACKGROUND / DISCUSSION:**

The applicant is requesting to rezone to allow apartment use. City Plan Commission recommended 7-0 to approve the proposed rezoning on June 16, 2022. As of July 20, 2022, the Planning Division has received two (2) emails in opposition to the request. See attached staff report for additional information.

**PRIOR COUNCIL ACTION:**

N/A

**AMOUNT AND SOURCE OF FUNDING:**

N/A

**HAVE ALL AFFECTED DEPARTMENTS BEEN NOTIFIED?**  YES  NO

**PRIMARY DEPARTMENT:** Planning & Inspections, Planning Division

**SECONDARY DEPARTMENT:** N/A

---

\*\*\*\*\*REQUIRED AUTHORIZATION\*\*\*\*\*

**DEPARTMENT HEAD:**

*Philip Etiwe*

---

ORDINANCE NO. \_\_\_\_\_

AN ORDINANCE CHANGING THE ZONING OF A PORTION OF THE EAST 300 FEET OF NORTH 150 FEET OF SOUTH 165 FEET OF TRACT 9-D, FIRST SUPPLEMENTAL MAP OF PARKLAND ADDITION, CITY OF EL PASO, EL PASO COUNTY, TEXAS FROM R-4 (RESIDENTIAL) TO A-O (APARTMENT/OFFICE) AND IMPOSING CONDITIONS. THE PENALTY IS AS PROVIDED FOR IN CHAPTER 20.24 OF THE EL PASO CITY CODE.

NOW THEREFORE, BE IT ORDAINED BY THE CITY COUNCIL OF THE CITY OF EL PASO:

Pursuant to Section 20.04.360 of the El Paso City Code, that the zoning of a portion of the East 300 feet of North 150 feet of South 165 feet of Tract 9-D, First Supplemental Map of Parkland Addition, located in the City of El Paso, El Paso County, Texas, be changed from R-4 (Residential) to A-O (Apartment/Office), as defined in Section 20.06.020, and that the zoning map of the City of El Paso be revised accordingly.

Further, that the property described above be subject to the following conditions which are necessitated by and attributable to the health and safety of the community, generated by the change of zoning in order to protect the health, safety and welfare of the residents of the City:

1. Structures shall not exceed more than two-stories.
2. That a five-foot (5') landscaped buffer with high-profile native or naturalized trees of at least two-inch (2") caliper and ten feet (10') in height shall be placed at twenty feet (20') on center along the property lines adjacent to residential zone districts or uses. The landscaped buffer shall be irrigated and maintained by the property owner at all times and shall be installed prior to the issuance of any certificates of occupancy.
3. Prior to issuing a certificate of occupancy, property owner must install an eight-foot (8') privacy fence along the northern property line.
4. Trash receptacles shall be located a minimum of seventy-five feet (75') away from residential lots located to the north of the property.

The penalties for violating the standards imposed through this rezoning ordinance are found in Section 20.24 of the El Paso City Code.

ADOPTED this \_\_\_\_\_ day of \_\_\_\_\_, 2022.

THE CITY OF EL PASO:


ATTEST:

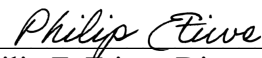
\_\_\_\_\_  
Oscar Leeser  
Mayor

\_\_\_\_\_  
Laura D. Prine  
City Clerk

APPROVED AS TO FORM:

APPROVED AS TO CONTENT:

  
\_\_\_\_\_  
Russell T. Abeln  
Assistant City Attorney

  
\_\_\_\_\_  
Philip F. Etiwe, Director  
Planning & Inspections Department

ORDINANCE NO. \_\_\_\_\_

Zoning Case No: PZRZ22-00015

# North of Woodrow Bean Transmountain Drive and East of Bomarc Street



REZONING

City Plan Commission — June 16, 2022 **REVISED**

**CASE NUMBER:** PZRZ22-00015  
**CASE MANAGER:** Nina Rodriguez, (915) 212-1561, RodriguezNA@elpasotexas.gov  
**PROPERTY OWNER:** The Venice Group, LLC  
**REPRESENTATIVE:** CEA Group  
**LOCATION:** North of Woodrow Bean Transmountain Dr. and East of Bomarc St. (District 4)  
**PROPERTY AREA:** 1.03 acres  
**REQUEST:** Rezone from R-4 (Residential) to A-O (Apartment/Office)  
**RELATED APPLICATIONS:** None  
**PUBLIC INPUT:** 2 emails in opposition received as of July 20, 2022

**SUMMARY OF REQUEST:** The applicant is requesting a rezone from R-4 (Residential) to A-O (Apartment/Office) to allow for apartments.

**STAFF RECOMMENDATION:** Staff recommends **APPROVAL WITH CONDITIONS** of the rezoning request based on its consistency with *Plan El Paso*, the City’s Comprehensive Plan and the G-3, Post-War future land use designation. The conditions are as follows:

1. Structures shall not exceed more than two-stories.
2. That a **five-foot (5')** landscaped buffer with high-profile native or naturalized trees of at least two-inch (2") caliper and ten feet (10') in height shall be placed at twenty feet (20') on center along the property lines adjacent to residential zone districts or uses. The landscaped buffer shall be irrigated and maintained by the property owner at all times and shall be installed prior to the issuance of any certificates of occupancy.
3. Prior to issuing a certificate of occupancy, property owner must install an eight-foot (8') privacy fence along northern property line.
4. Trash receptacles shall be located a minimum of 75' away from residential lots located to the north of property.

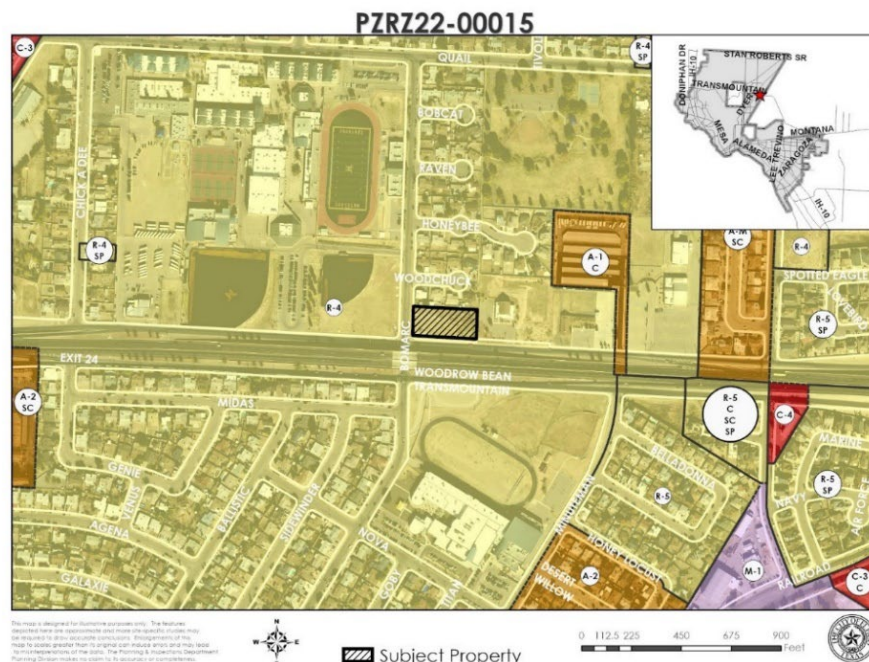


Figure A. Subject Property & Immediate Surroundings



**DESCRIPTION OF REQUEST:** The applicant is requesting to rezone a 1.03-acre property from R-4 (Residential) to A-O (Apartment/Office) to allow for apartments. The conceptual plan shows a twenty-four (24) apartment unit complex. Access to the subject property is proposed from Bomarc Street and Woodrow Bean Transmountain.

**COMPATIBILITY WITH NEIGHBORHOOD CHARACTER:** The proposed apartment use and A-O (Apartment/Office) district is compatible with the residential districts in the immediate area and is in character with the areas surrounding the subject property. The adjacent properties to the north are single-family dwelling uses in an R-4 (Residential) zoning district, and the properties to the west, east, and south are public school and church uses also zoned R-4 (Residential). The subject property is located off the Woodrow Bean Transmountain Drive highway at the Northeast corner of Bomarc Street and has the potential to serve as a buffer between the highway and the single-family dwellings located directly behind. There are existing sidewalks along Woodrow Bean Transmountain Drive. By rezoning the subject property to an A-O (Apartment/Office) district, the area has the potential to provide more diverse residential options. The distance to the nearest school, Parkland High School, is approximately 0.06 miles and the distance to the nearest park, Franklin Park, is 0.28 miles.

<b>COMPLIANCE WITH PLAN EL PASO/REZONING POLICY – When evaluating whether a proposed rezoning is in accordance with Plan El Paso, consider the following factors:</b>	
<b>Criteria</b>	<b>Does the Request Comply?</b>
<p><b>Future Land Use Map:</b> Proposed zone change is compatible with the Future Land Use designation for the property:</p> <p><b>G-3, Post-War:</b> This sector applies to transitional neighborhoods typically developed from the 1950s through the 1980s. Streets were laid out with curvilinear patterns without alleys and shopping centers are located at major intersections behind large parking lots. This sector is generally stable but would benefit from strategic suburban retrofits to supplement the limited housing stock and add missing civic and commercial uses.</p>	<p>Yes. The proposed development is compatible with the future land use designation. The proposed development has the potential to increase the available housing stock in an area facing limited housing stock.</p>
<p><b>Compatibility with Surroundings:</b> The proposed zoning district is compatible with those surrounding the site:</p> <p><b>A-O (Apartment-Office) District:</b> The purpose of these districts is to promote and preserve residential development within the city associated with a landscape more urban in appearance and permitting a mixture of housing types. It is intended that the district regulations allow for medium densities of dwelling units supported by higher intensity land uses located at the periphery of single-family neighborhoods providing that the overall character and architectural integrity of the neighborhood is preserved. The regulations of the districts will permit building types designed for transition from areas of low-density residential neighborhoods to other residential areas, and certain nonresidential uses and support facilities.</p>	<p>Yes. Adjacent properties to the north, south, east and west of the subject property are zoned R-4 (Residential) zones. The proposed A-O (Apartment/Office) zoning district is compatible with the surrounding uses as it also serves to provide residential use purpose. However, by rezoning the subject property from R-4 (Residential) to A-O (Apartment/Office), future developments can achieve more density and more diverse residential uses, thereby serving the community with a variety of housing options.</p>
<p><b>Preferred Development Locations:</b> Located along an arterial (or greater street classification) or the intersection of two collectors (or greater street classification). The site for proposed rezoning is not located mid-block, resulting in it being the only</p>	<p>Yes. Access to the subject property is proposed from Bomarc Street; a local street and Woodrow Bean Drive, a major arterial as classified under the City’s Major Thoroughfare Plan. The classification of these streets are appropriate for the proposed development. While</p>

<b>COMPLIANCE WITH PLAN EL PASO/REZONING POLICY – When evaluating whether a proposed rezoning is in accordance with <i>Plan El Paso</i>, consider the following factors:</b>	
property on the block with an alternative zoning district, density, use and/or land use.	the subject property will be the only A-O (Apartment-Office) zoning district on the corner of the intersection surrounded by R-4 (Residential) zoning districts, changing the zoning designation of the subject property allows for an increase in density and more types of residential uses than allowed in R-4 (Residential) districts. This has the potential to provide the area with more housing units and flexible uses to meet a wider range of needs for the community.
<b>THE PROPOSED ZONING DISTRICT’S EFFECT ON THE PROPERTY AND SURROUNDING PROPERTY, AFTER EVALUATING THE FOLLOWING FACTORS:</b>	
<b>Historic District or Special Designations &amp; Study Area Plans:</b> Any historic district or other special designations that may be applicable. Any adopted small areas plans, including land-use maps in those plans.	This property does not fall within any historic districts, special designations, or study plan areas.
<b>Potential Adverse Effects:</b> Potential adverse effects that might be caused by approval or denial of the requested rezoning.	There are no anticipated adverse impacts.
<b>Natural Environment:</b> Anticipated effects on the natural environment.	The subject property does not involve green field or environmentally sensitive land or arroyo disturbance.
<b>Stability:</b> Whether the area is stable or in transition.	The area is stable with no rezoning cases within the last 10 years.
<b>Socioeconomic &amp; Physical Conditions:</b> Any changed social, economic, or physical conditions that make the existing zoning no longer suitable for the property.	The property directly abuts Woodrow Bean Transmountain Dr. and serves as a buffer along Woodrow Bean Transmountain Dr. for single-family properties located directly behind the subject property. Higher density uses are more desirable in these areas to serve as a buffer. The proposed development would also serve as infill for a currently vacant corner lot.

**ADEQUACY OF PUBLIC FACILITIES, SERVICES AND INFRASTRUCTURE:** Access to the subject property is proposed from Bomarc Street; a local street and Woodrow Bean Transmountain Drive, classified as a freeway per the City of El Paso’s Major Thoroughfare Plan (MTP) and are adequate to support the proposed use of apartments. The proposed development is within walking distance of local schools and parks, and sidewalks are already present along Woodrow Bean Transmountain Drive.

**SUMMARY OF DEPARTMENTAL REVIEW COMMENTS:** No adverse comments were received for the rezoning request from the reviewing departments.

**PUBLIC COMMENT:** The subject property does not reside within the boundaries of any neighborhood or civic associations identified by the City of El Paso. A community meeting was held on June 11, 2022 providing information on the proposed rezoning, five residents attended the meeting. Notice of the proposed rezoning was provided to all property owners within 300 feet of subject property on June 1, 2022. As of July 20, 2022, the Planning Division has received (2) emails in opposition to the request, and no other communication in support nor opposition. One phone call of inquiry was received from the public.

**RELATED APPLICATIONS:** None.

**CITY PLAN COMMISSION OPTIONS:** The purpose of the Zoning Ordinance is to promote the health, safety, morals and general welfare of the City. The City Plan Commission (CPC) has the authority to advise City Council on Zoning matters. In evaluating the request, the CPC may take any of the following actions:

1. **Recommend Approval** of the rezoning request, finding that the request is in conformance with the review criteria of *Plan El Paso* as reflected in the Staff Report, or that the request is in conformance with other criteria that the CPC identifies from the Comprehensive Plan.
2. **Recommend Approval of the rezoning request With Modifications** to bring the request into conformance with the review criteria of *Plan El Paso* as reflected in the Staff Report, or other criteria that the CPC identifies from the Comprehensive Plan. **(Staff Recommendation)**
3. **Recommend Denial** of the rezoning request, finding that the request does not conform to the review criteria of *Plan El Paso* as reflected in the Staff Report, or other criteria that the CPC identifies from the Comprehensive Plan.

**ATTACHMENTS:**


1. Future Land Use Map
2. Neighborhood Notification Boundary Map
3. Generalized Plot Plan
4. Department Comments
5. Public Comment

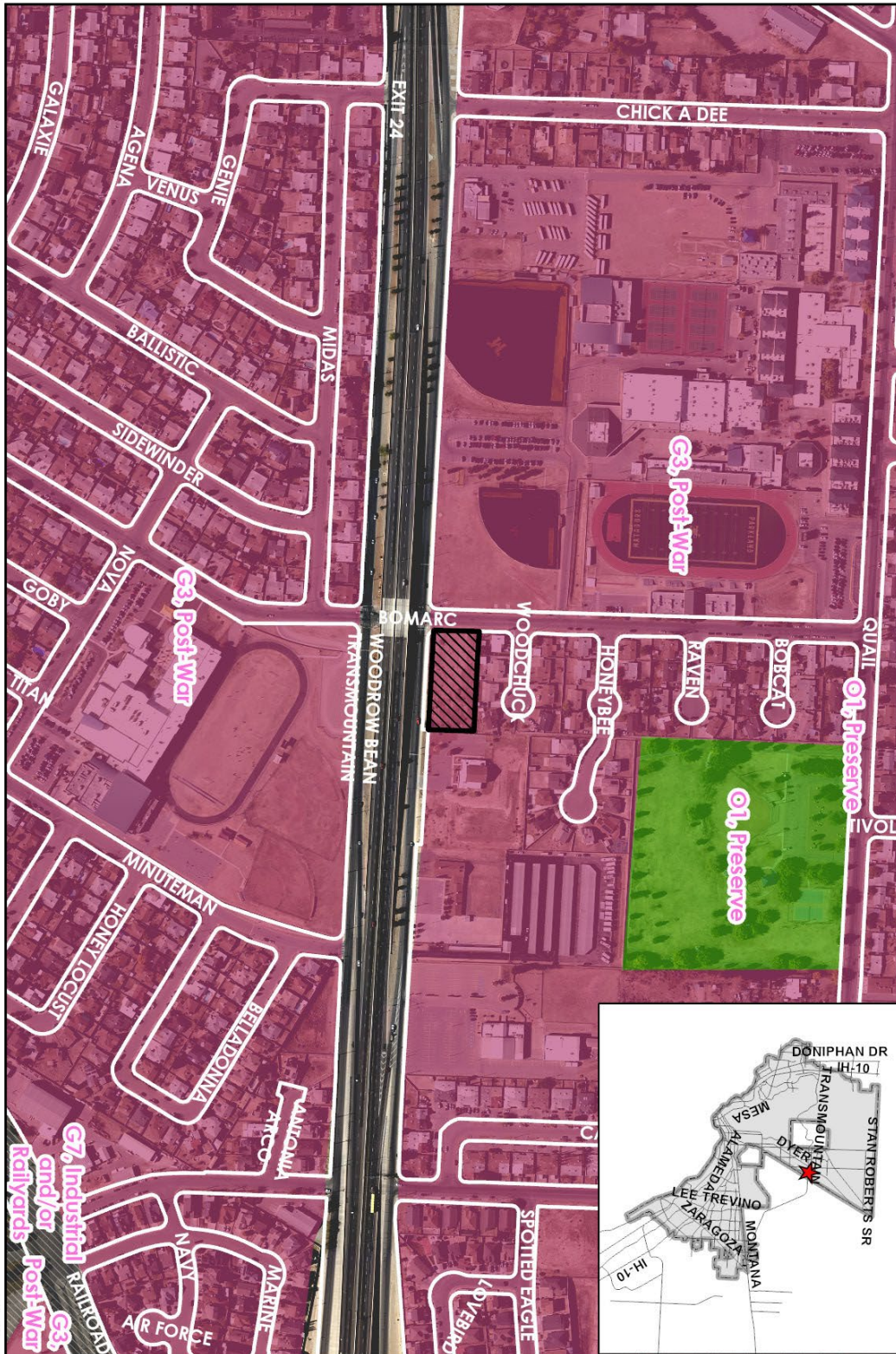
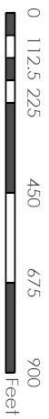


# ATTACHMENT 1

This map is designed for illustrative purposes only. The features depicted here are approximate and more site-specific studies may be required to draw accurate conclusions. Engagements of this map to scales greater than its original can include errors and may lead to misinterpretations of the data. The Planning & Inspection Department Planning Division makes no claim to its accuracy or completeness.



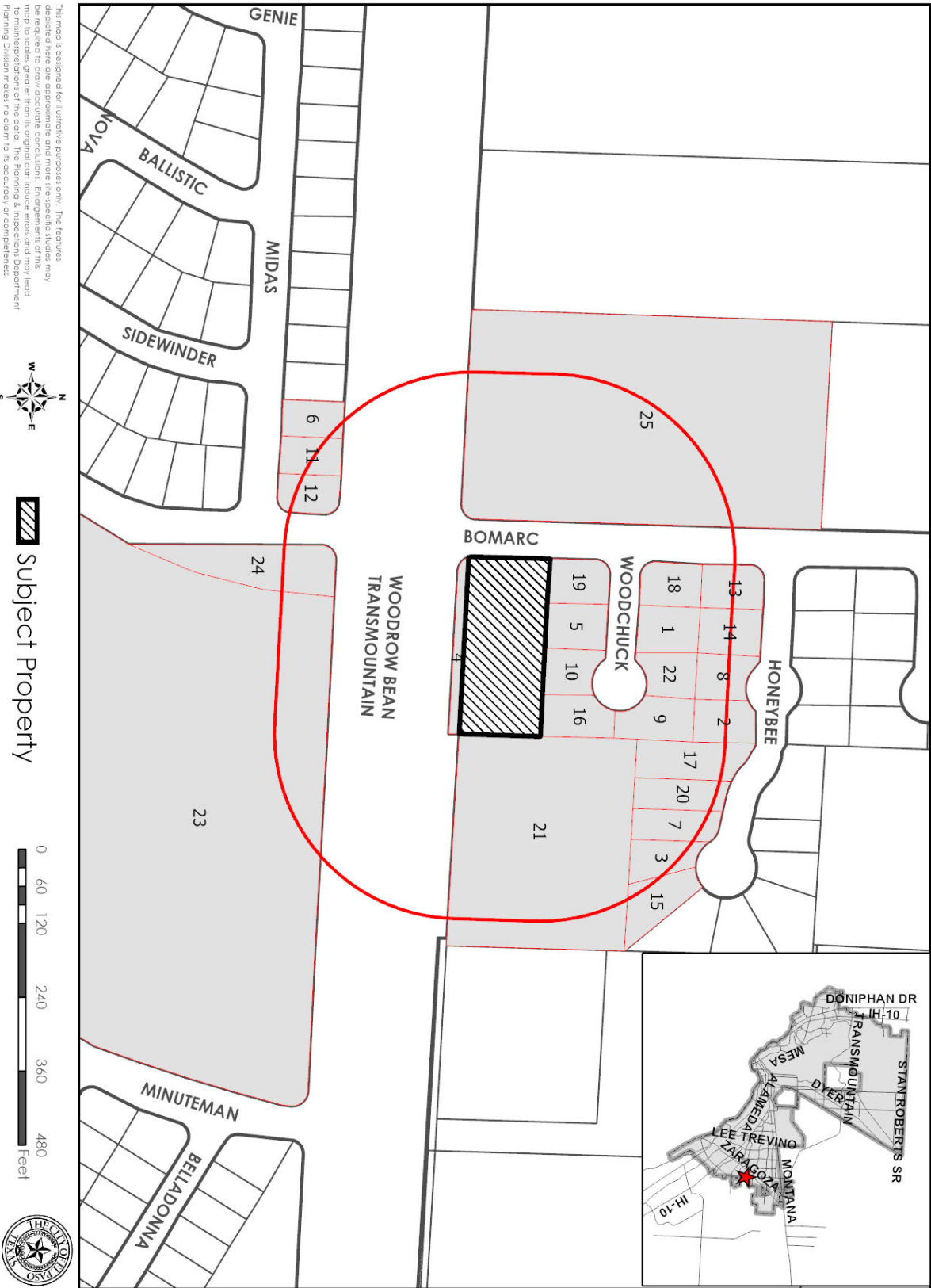
 Subject Property



PZR222-00015

# ATTACHMENT 2

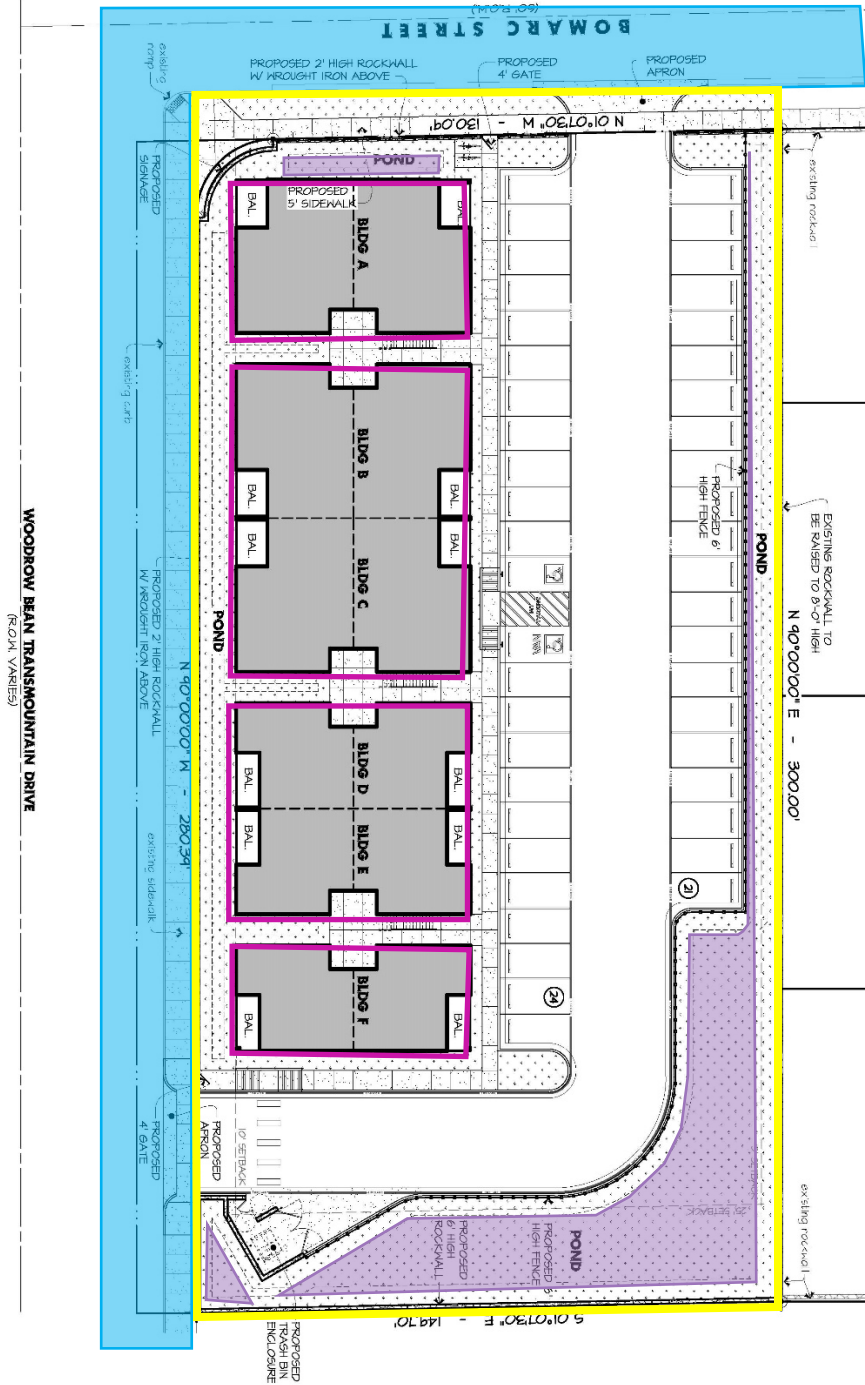
PZR22-00015





# ATTACHMENT 3

- 6 ONE BEDROOM UNIT PER STORY (X 2 STORIES) = 12 UNITS
- 6 TWO BEDROOM UNIT PER STORY (X 2 STORIES) = 12 UNITS
- 24 TOTAL UNITS**
- 42 PARKING SPACES REQUIRED (INCLUDING 2 HANDICAP SPACES)
- 45 PARKING SPACES PROVIDED (INCLUDING 2 HANDICAP SPACES)



**SITE PLAN** (SCHEME "E1")

SCALE: 1" = 20'-0"

**CONCEPTUAL DESIGN**

**SP1.1**  
1 OF 1  
ARCHITECTURAL  
SITE PLAN - SCHEME

JUNE 15, 2022

NEW APARTMENT COMPLEX FOR

# BOMARC APARTMENTS

BOMARC ST. & WOODROW BEAM TRANSMOUNTAIN DR.

EL PASO, TEXAS 79924

**CONCEPTUAL DESIGN**  
THIS DOCUMENT WAS PREPARED BY  
CONCEPTUAL DESIGN ARCHITECTS, INC.  
ON 06-15-2022 FOR THE PROJECT OF  
BOMARC APARTMENTS IN EL PASO, TEXAS.  
IT IS NOT TO BE USED OR REPRODUCED  
WITHOUT THE WRITTEN PERMISSION OF  
CONCEPTUAL DESIGN ARCHITECTS, INC.

ARCHITECT

# **ATTACHMENT 4**

## **Planning and Inspections Department – Planning Division**

Staff recommends approval of the rezoning request with the following conditions:

1. Structures shall not exceed more than two-stories.
2. That a ten-foot (10') landscaped buffer with high-profile native or naturalized trees of at least two-inch (2") caliper and ten feet (10') in height shall be placed at twenty feet (20') on center along the property lines adjacent to residential zone districts or uses. The landscaped buffer shall be irrigated and maintained by the property owner at all times and shall be installed prior to the issuance of any certificates of occupancy.

## **Planning and Inspections Department – Plan Review & Landscaping Division**

The generalized site plan is not being reviewed for conformance due to conceptual nature. No objections to proposed rezoning. At the time of submittal for building permit, the project will need to comply with all applicable provisions of the ICC, TAS and Municipal Code.

## **Planning and Inspections Department – Land Development**

1. Show proposed drainage flow patterns on the site plan and identify the discharge and/or storage location(s) for all storm-water runoff within the subdivision.
2. As per Municipal Code: new developments and redevelopments are required to maintain the pre-development hydrologic response in their post-development state as nearly as practicable in order to reduce flooding. The code also encourages the use of nonstructural storm water management such as the preservation of greenspace, rainwater harvesting within landscaped areas, and other conservation efforts, to the maximum extent practicable, per Chapter 19.19, Section 19.19.010, and Subparagraph A-2 & A-5.

## **Fire Department**

Recommend approval.

## **Police Department**

No comments received.

## **911 District/El Paso County 911 District**

No comments received.

## **Environmental Services**

No comments received.

## **Streets and Maintenance Department**

No comments received.

## **Sun Metro**

No comments received.

## **El Paso Water Utilities**

El Paso Water does not object to this request.

Woodrow Bean is a Texas Department of Transportation (TxDOT) right-of-way. All proposed water and sanitary sewer work to be performed within Woodrow Bean right-of-way requires written permission from TxDOT.

There is an existing 6-inch/8-inch diameter water main along Bomarc St. The water main is located approximately 20-ft west of the eastern right-of-way. This main is available for service.

There is an existing 30-inch diameter flow line along Woodrow Bean Transmountain Rd. This water main is located approximately 17-feet south of the northern right-of-way. This main is not available for service.

Previous water pressure from fire hydrant #08996 located on Woodrow Bean Transmountain Rd., approximately 495-ft east of Bomarc St. has yield a static pressure of 90 (psi), a residual pressure of 84 (psi), and a discharge of 1113 gallons per minute. The owner should, for his own protection and at his own expense, install at the discharge side of each water meter a pressure regulator, strainer and relief valve, to be set for pressure as desired by the customer. The Lot owner shall be responsible for the operation and maintenance of the above-described water pressure regulating device.

**Sanitary Sewer:**

There is an existing 8-inch diameter sanitary sewer main extending along Bomarc St. The sewer main is located approximately 25-feet east of the western right-of-way line. This main is available for service.

**General:**

EPWater requires a new service application to provide service to the property. New service applications are available at 1154 Hawkins, 3rd floor and should be made 6 to 8 weeks in advance of construction to ensure water for construction work. A site plan, utility plan, grading and drainage plans, landscaping plan, the legal description of the property and a certificate-of-compliance are required at the time of application. Service will be provided in accordance with the current EPWater – PSB Rules and Regulations. The applicant is responsible for the costs of any necessary on-site and off-site extensions, relocations or adjustments of water and sanitary sewer lines and appurtenances.

**Stormwater:**

1. As per Municipal Code: new developments and redevelopments are required to maintain the pre-development hydrologic response in their post-development state as nearly as practicable in order to reduce flooding. The code also encourages the use of nonstructural storm water management such as the preservation of greenspace, water harvesting, and other conservation efforts, to the maximum extent practicable, per Chapter 19.19, Section 19.19.010, and Subparagraph A-2 & A-5.
2. The small concrete channel that runs behind this property was not designed to take in this storm sewer runoff.
3. EPWater-SW requires on-site retention of all developed runoff; ensure runoff does not flow off-site.
4. Any proposed ponding area shown, shall have enough capacity to hold the developed runoff for a designated 100-yr. storm event. Label the pond as “Private”.

*Note: To be complied prior to construction*

**Texas Department of Transportation**

Please submit grading and drainage plans for TxDOT review.

*Note: To be complied prior to construction*

**El Paso County Water Improvement District**

No comments received.



# ATTACHEMENT 5

**From:** [David Mullen](#)  
**To:** [Rodriguez, Nina A.](#)  
**Subject:** Case: PZRZ22-00015  
**Date:** Wednesday, June 8, 2022 10:42:46 AM

---

You don't often get email from dmullen69@att.net. [Learn why this is important](#)

**CAUTION:** This email originated from outside of the City of El Paso. Do not click links or open attachments unless you recognize the sender and know the content is safe. If suspicious, use **Phish Alert** or forward to [SpamReport@elpasotexas.gov](mailto:SpamReport@elpasotexas.gov).

To Whom It May Concern:

This email is in regards to a rezoning request for the northeast corner of Loop 375 access road and Bomarc Street.

I strongly oppose this proposal, as it would be unsafe to put an apartment complex on that corner for the following reasons:

1. There is at least one accident at that intersection every quarter and sometimes more. Putting an apartment complex there would only increase the chances of those numbers increasing.
2. The foot traffic during the school year at that intersection is very heavy, both before school and after.
3. During football season, there is barely room to get down Bomarc Street in your vehicle, as attendees to the games park on both sides of the street. With an apartment complex added to the mix, that would be adding to an already crowded area.
4. Most importantly, the safety of the school children would be at an increased risk. And that mostly applies to the children who obey the crossing lights. Those who do not, and there are very many, would be at greater risk.

It is difficult to imagine that the city would even consider this proposal. Just a quick look would indicate the dangers this complex would bring to this neighborhood.

We strongly oppose this action!

Very Respectfully,

David & Blanca Mullen  
6024 Honeybee Ct  
El Paso, TX 79924  
(915) 471-9409

**From:** [David Mullen](#)  
**To:** [Rodriguez, Nina A.](#)  
**Subject:** Rezoning at Loop 375 and Bomarc Streeta - PZRZ-22-00015  
**Date:** Tuesday, July 19, 2022 6:59:28 PM

---

You don't often get email from dmullen69@att.net. [Learn why this is important](#)

**CAUTION:** This email originated from outside of the City of El Paso. Do not click links or open attachments unless you recognize the sender and know the content is safe. If suspicious, use **Phish Alert** or forward to [SpamReport@elpasotexas.gov](mailto:SpamReport@elpasotexas.gov).

**Good Day:**

Attached are photos of an accident that occurred on 16 June 2022, at the corner you are proposing to put an apartment complex.

Accidents occur at this corner at least once every three to four months. The children in this area would be in greater danger if an apartment complex is built on this corner, as you would be adding to the number of children who would cross the intersection.

If this is approved, even for a business, accidents will increase.

For the sake of the children, do not allow this proposal go forward.

Thank you for your attention in this matter.

**El Capitan**







**From:** [Jorge Azcarate](#)  
**To:** [Rodriguez, Nina A.](#)  
**Cc:** [Carlos Silveyra](#); [Garcia, Raul](#)  
**Subject:** Fwd: Open Records Request :: W109742-060922  
**Date:** Monday, June 13, 2022 12:34:46 PM

---

**CAUTION:** This email originated from outside of the City of El Paso. Do not click links or open attachments unless you recognize the sender and know the content is safe. If suspicious, use **Phish Alert** or forward to [SpamReport@elpasotexas.gov](mailto:SpamReport@elpasotexas.gov).

Nina,

Please see below on responses from El Paso Police Dept. On our open records request. Thank you.

Sincerely,  
Jorge L. Azcarate, P.E., CFM

---

**From:** The City of El Paso <[ElPaso@govqa.us](mailto:ElPaso@govqa.us)>  
**Sent:** Saturday, June 11, 2022 11:22 AM  
**To:** Jorge Azcarate <[jazcarate@ceagroup.net](mailto:jazcarate@ceagroup.net)>  
**Subject:** Open Records Request :: W109742-060922

--- Please respond above this line ---



06/11/2022

VIA ELECTRONIC MAIL ([jazcarate@ceagroup.net](mailto:jazcarate@ceagroup.net))

President Jorge Azcarate 4712  
Woodrow Bean, Suite F

El Paso TX 79924

Re: Open Records Request #W109742-060922

Dear President Jorge Azcarate:

Your request, received 06/09/2022, has been forwarded to me and is being treated as a request for records under the Texas Public Information Act (Tex. Gov't Code Ann. §552.001 *et seq.*). You requested the following information:

*"...Accidents information for the intersection of Bomarc and Woodrow Bean (Trans-mountain) in NE El Paso. Any fatalities at the intersection.*

*Information being requested is for the last 3 years. Information being used for a Traffic Study."*

Please be advised that I have been informed that there are no responsive documents pertaining to your request. As no responsive documents have been located, there is no charge associated with this response and your request is now considered closed. PLEASE CONTACT TEXAS DEPARTMENT OF TRANSPORTATION

Sincerely,

Alexis Esquivel,C1722  
Police Records Specialist/Open Records



---

File #: 22-920, Version: 1

---

**CITY OF EL PASO, TEXAS  
LEGISTAR AGENDA ITEM SUMMARY FORM**

**DISTRICT, DEPARTMENT, CONTACT INFORMATION:**

*Please choose District and Department from drop down menu. Please post exactly as example below.  
No Title's, No emails. Please use ARIAL 10 Font.*

**District 8**

Planning and Inspections, Philip F. Etiwe, (915) 212-1553

Planning and Inspections, Armida R. Martinez, (915) 212-1605

**AGENDA LANGUAGE:**

*This is the language that will be posted to the agenda. Please use ARIAL 11 Font.*

An Ordinance granting a Special Privilege License to 1031 Firestone, LLC to permit the construction, installation, maintenance use and repair of an aerial encroachment of an outdoor stairway for additional access to the property located at 1025 Texas Avenue, El Paso, Texas; setting the License term for a term of fifteen years (15) with one (1) renewable fifteen (15) year term.

Subject Property: 1025 Texas

Applicant: 1031 Firestone, LLC., NESV2022-00002

**CITY OF EL PASO, TEXAS  
AGENDA ITEM  
DEPARTMENT HEAD'S SUMMARY FORM**

**AGENDA DATE:** July 19, 2022  
**PUBLIC HEARING DATE:** August 2, 2022

**CONTACT PERSON(S) NAME AND PHONE NUMBER:** Philip F. Etiwe, (915) 212-1553  
Armida R. Martinez, (915) 212-1605

**DISTRICT(S) AFFECTED:** District 8

**STRATEGIC GOAL:** #3 Promote the Visual Image of El Paso

**SUBGOAL:** 3.2 Set one standard for infrastructure across the city

**SUBJECT:**

An Ordinance granting a Special Privilege License to 1031 Firestone, LLC to permit the construction, installation, maintenance use and repair of an aerial encroachment of an outdoor stairway for additional access to the property located at 1025 Texas Avenue, El Paso, Texas; setting the License term for a term of fifteen years (15) with one(1) renewable fifteen (15) year term.

Subject Property: 1025 Texas  
Applicant: 1031 Firestone, LLC, NESV2022-00002

**BACKGROUND / DISCUSSION:**

The applicant is requesting the stairway as a second point of access to the second floor of the building. The applicant is opting to construct the stairway behind the building in the alley due to budget concerns and disruption of the floor layout.

**PRIOR COUNCIL ACTION:**

N/A

**AMOUNT AND SOURCE OF FUNDING:**

N/A

**HAVE ALL AFFECTED DEPARTMENTS BEEN NOTIFIED?**  YES  NO

**PRIMARY DEPARTMENT:** Planning & Inspections, Planning Division

**SECONDARY DEPARTMENT:** N/A

---

\*\*\*\*\*REQUIRED AUTHORIZATION\*\*\*\*\*

**DEPARTMENT HEAD:**

*Philip Etiwe*

---



ORDINANCE NO. \_\_\_\_\_

**AN ORDINANCE GRANTING A SPECIAL PRIVILEGE LICENSE TO 1031 FIRESTONE, LLC TO PERMIT THE CONSTRUCTION, INSTALLATION, MAINTENANCE, USE, AND REPAIR OF AN AERIAL ENCROACHMENT OF AN OUTDOOR STAIRWAY FOR ADDITIONAL ACCESS TO THE PROPERTY LOCATED AT 1025 TEXAS AVENUE, EL PASO, TEXAS; SETTING THE LICENSE TERM FOR A TERM OF FIFTEEN YEARS (15) WITH ONE (1) RENEWABLE FIFTEEN (15) YEAR TERM.**

**NOW THEREFORE BE IT ORDAINED BY THE CITY COUNCIL OF THE CITY OF EL PASO:**

**SECTION 1. DESCRIPTION**

The City of El Paso (hereinafter called “City”) hereby grants a Special Privilege License (hereinafter called “License”) to **1031 FIRESTONE, LLC** (hereinafter referred to as the “Grantee”), to permit the construction, installation, future maintenance, use and repair of an aerial encroachment of an outdoor stairway encroaching a total of 225 square feet onto the public right-of-way over a portion of City right-of-way along the alley located behind the property located at 1025 Texas Avenue more particularly described as *Exhibit “A,”* which is made a part hereof for all purposes (hereinafter referred to as the “License Area”)

**SECTION 2. LICENSE AREA**

The aerial rights granted herein over a portion of right-of-way along the alley behind the property located at 1025 Texas Avenue and legally described as being a portion of a 20’ alley, Block 3, Franklin Heights Addition, City of El Paso, El Paso County Texas, to permit the construction, installation, future maintenance, use and repair of the outdoor stairway is more particularly shown in *Exhibits “B”* which is made a part hereof for all purposes (hereinafter referred to as the “License Area”).

**SECTION 3. USE OF PROPERTY**

This License is granted solely for the encroachment onto City right of way, which includes the requirement and responsibility for construction, installation, future maintenance, use, and repair of the outdoor stairway encroachment. Grantee agrees to maintain the License Area in proper working condition and in accordance with all applicable City specifications, which includes

NESV2022-00002

restoration to allow and not impede the City's use of the right of way for pedestrian and vehicular access.

Except for the waiver of fees as provided herein, this Special Privilege License shall not be construed to waive any City permit requirements. Grantee shall be responsible for all maintenance. Grantee, at no cost to the City, shall clean up all litter and debris within the License Area, leaving City rights-of-way in a clean and orderly condition at all times.

This License shall not permit or be construed to permit any other private use of the City right-of-way that impairs its function as a City right-of-way. Except for maintenance of the outdoor stairway as provided herein, Grantee shall not construct any additional improvements, or make any additions or alterations on, above, or below the City right-of-way, without prior written consent of the El Paso City Manager or designee.

#### **SECTION 4. REGULATION OF CONSTRUCTION**

The work done by Grantee in installation, replacing, repairing, reconstructing, or maintaining the outdoor stairway shall be subject to all applicable laws, rules and regulation of the City, State, and laws that are applicable to the construction, maintenance and repair of the outdoor stairway. Work done in connection with the installation, repair and maintenance of the outdoor stairway is subject to the continuing police power of the City.

In the event that Grantee desires to reconstruct, repair, maintain, or replace the outdoor stairway built hereunder, Grantee shall obtain all applicable permits required by the City. Where proposed, any excavation or trenching and other construction in the License Area shall be so carried out as to interfere as little as practical with the surface use of the License Area in accordance with any lawful and reasonable direction given by or under the authority of the governing body of the City under the police and regulatory powers necessary to provide for public convenience.

Grantee covenants and agrees that Grantee shall, at Grantee's own expense, repair all water lines, storm and sanitary sewer lines, service lines and water meters owned by the City that Grantee,

Grantee's employees, contractors, agents or assigns damage so that such repair of the water lines, storm and sanitary sewer lines and water meters shall comply with any applicable City codes.

The City shall have the power at any time to order and require Grantee to remove and abate any portion of the License Area that is dangerous to life or property; Should Grantee, after notice, fail or refuse to comply within a reasonable time, the City shall have the power or abate the same, at the expense of Grantee. In the event City removes or abates the License Area as provided herein, Grantee shall not be compensated for the loss of the License Area, or revenues associated with the area, nor shall the City be liable to the Grantee for any direct, indirect or consequential damages due to the removal or abatement of the License Area.

#### **SECTION 5. TERM**

This Special Privilege shall be for a term of FIFTEEN (15) years from the effective date hereof, unless terminated earlier as provided herein. At the end of this term, the City shall have the unilateral option of renewing this Special Privilege for One (1) additional FIFTEEN (15) year term upon the request of the Grantee and approval of the City Manager. If Grantee wishes the City to renew this License, Grantee shall submit a request in writing to the City no later than three (3) months prior to the expiration date of this License. Should Grantee fail to submit such request for the extension of this License to the City as herein required, the License shall expire upon the expiration date. Grantee understands, agrees, and accepts that the city may require the terms, conditions, and provisions of this License be modified as a condition for renewing the grant of the encroachment within the License Area as permitted by this License.

#### **SECTION 6. WORK DONE BY OTHERS**

Throughout the term of this License, the City expressly reserves the right to install, repair, or reconstruct the City right-of-way used or occupied by Grantee, any streets or alleys and all ancillary public uses, usual and customary in connection with streets and alleys, expressly including but not limited to, drainage facilities and structures.

The City reserves the right, subject to further conditions described in this paragraph, to lay and permit to be laid, utility lines including, but not limited to, storm and sanitary sewer, gas, water, and other

NESV2022-00002

pipelines or cables, and to do and permit to be done, any underground and overhead installation or improvement that may be deemed necessary or proper by the governing body of the City in, across, along, over or under the License Area occupied by Grantee, and to change any geometrics of the right-of-way. The City shall notify Grantee of work to be performed as herein described. The City shall not be liable to Grantee for any damage resulting there from, nor shall the City be liable to Grantee for any damages arising out of the performance of any work by the City, its contractors or subcontractors, not willfully and unnecessarily occasioned; provided, however, nothing herein shall relieve any other persons or entities from liability for damage to the License Area.

#### **SECTION 7. RESERVATION OF SURFACE, SUBSURFACE, AND AIRSPACE RIGHTS**

The City reserves the right to use the surface or subsurface or airspace within the License Area for any public purposes allowed by law and deemed necessary by the City and to do or permit to be done any work in connection therewith which may be deemed necessary or proper by the City on, across, along, under or over said License Area occupied by Grantee provided such use does not interfere with Grantee's use of the License Area. Whenever by reason of said work in connection with said purposes it shall be deemed necessary by the City to alter, change, adapt, conform or relocate portions of the outdoor stairway encroachment such alteration or change or relocation shall be made by Grantee when ordered in writing by the City Manager or designee without any claim for reimbursement or damages against the City.

#### **SECTION 8. CONSIDERATION**

As consideration for this special Privilege License, the Grantee shall pay to the City ONE THOUSAND SIXTY AND 00/100 DOLLARS (\$1,060) per year. The annual fee shall remain the same for a period of one year from the date of execution by the El Paso City Council and shall be subject to change after each one year period the License remains in effect. The El Paso City Council retains the right to increase or decrease the annual fee specified in this License.

The City shall notify the Grantee of any proposed changes in fees as prescribed in Section 15 (Notice) of this License. This License is granted on the condition the Grantee pay for all costs associated with the outdoor stairway, as well as all costs for the restoration of the License Area upon the termination of the License.

The first annual consideration shall be due and owing prior to the El Paso City Council approval of the License. The advance payment shall be in the form of a cashier's check or business check payable to "The City of El Paso" and delivered to the Planning and Inspections Department for remittance to the Financial Services Department. If the Special Privilege is disapproved by the El Paso City Council, a full refund of the payment shall be made by the Financial Services Department within fifteen (15) days of the denial action. Subsequent annual considerations shall be due the first day of the month in which the License has been granted by the El Paso City Council and remitted to the Financial Services Department.

**ADVANCE PAYMENT OPTION:**

Grantee shall have the option of pre-paying the City the entire amount for the FIFTEEN (15) year term of the License, prior to the execution of this License. The FIFTEEN (15) year amount is equal to THIRTEEN THOUSAND THIRTY THREE AND 84/100 DOLLARS (\$13,033.84). Said \$13,033.84 reflects the net present value (NPV) at a three percent (3%) discount rate of the annual fees for the entire FIFTEEN (15) year term of the License. Should Grantee select the advance payment option, Grantee shall not be entitled to a refund of the consideration paid to the City in case of cancellation by the City and/or the Grantee prior to the expiration of the 15 year term.

Both the annual consideration and the advance payment shall be exclusive of and in addition to all general municipal taxes of whatever nature, including, but not limited to, ad valorem taxes, assessments for public improvements or any other assessments that may be enacted during the term of this License or any renewal, except hereinafter provided. The fee established in this section shall not be affected by any relocation of Grantee's outdoor stairway required by the City pursuant to this License.

The fee payment shall be exclusive of and in addition to all costs of obtaining required permits, plans and other approvals as necessary to conform to all other applicable City Special Privileges and regulations.

**SECTION 9. INSURANCE**

Prior to commencement of any future construction, repairs, or maintenance operations during the term of this License, Grantee's Contractors or Agents shall provide the City with a certificate of insurance

NESV2022-00002

and shall maintain such insurance in effect during the term of this License. The City shall be named as an additional insured on all of the Grantee's insurance policies that are required by this License. Failure to maintain insurance after receipt of notice of default and thirty (30) days to cure shall be a material breach of this License and a basis for termination of this License by the City.

Grantee's contractors or agents shall obtain and provide a general liability policy with a one million dollar (\$1,000,000.00) limit, per occurrence, for personal injury, death, and property damage, with a minimum two million dollar (\$2,000,000.00) general aggregate limit. These amounts are not a limitation upon the Grantee's Contractors or Agents agreement to indemnify and hold the City harmless.

Grantee shall procure said insurance with a solvent insurance company authorized to do business in Texas. Grantee shall provide a policy or certificate shall provide that the insurance cannot be canceled, modified or the amount of coverage changed without thirty (30) days prior written notice to the Financial Services Department, or ten (10) days prior written notice to the Financial Services Department for cancellation based on non-payment of insurance premiums. Grantee shall file a copy of the policy of insurance with Financial Services Department and the Planning and Inspections Department. If the policy is not kept in full force and effect throughout the term of this License, the License shall automatically become void.

#### **SECTION 10. INDEMNITY**

**AS A CONDITION OF THIS LICENSE, GRANTEE SHALL INDEMNIFY, DEFEND AND HOLD HARMLESS THE CITY, ITS OFFICERS, AGENTS, SERVANTS AND EMPLOYEES FROM AND AGAINST ANY AND ALL COSTS, CLAIMS, LIENS, DAMAGES, LOSSES, EXPENSES (INCLUDING BUT NOT LIMITED TO ATTORNEYS' FEES AND COSTS), FEES, FINES, PENALTIES, PROCEEDINGS, DEMANDS, CAUSES OF ACTION, LIABILITY AND SUITS OF ANY KIND AND NATURE, INCLUDING BUT NOT LIMITED TO, PERSONAL INJURY OR DEATH OR PROPERTY DAMAGE, ARISING OUT OF, RESULTING FROM OR RELATED TO THE GRANTEE'S ACTIVITIES UNDER THIS LICENSE, INCLUDING ANY ACT OR OMISSION BY THE GRANTEE, THE GRANTEE'S AGENTS, EMPLOYEES OR SUBCONTRACTORS, ALL,**

NESV2022-00002

**WITHOUT, HOWEVER, WAIVING GOVERNMENTAL IMMUNITY AVAILABLE TO THE CITY, HEREAFTER, THE “DAMAGES”. THIS INDEMNIFICATION SHALL APPLY EVEN WHERE SUCH DAMAGES DESCRIBED ABOVE INVOLVE THE NEGLIGENCE OR ALLEGATIONS OF NEGLIGENCE ON THE PART OF THE CITY, ITS OFFICERS, AGENTS OR EMPLOYEES.**

The provisions of this indemnification are solely for the benefit of the parties hereto and not intended to create or grant any rights, contractual or otherwise, to any person or entity. Without modifying the conditions of preserving, asserting, or enforcing any legal liability against the City as required by the City Charter or any law, the City will promptly forward to the Grantee every demand, notice, summons, or other process received by the City in any claim or legal proceeding contemplated herein. Grantee shall investigate or cause the investigation of accidents or occurrences involving such damages, negotiate or cause to be negotiated the claim as the Grantee may deem expedient, and defend or cause to be defended on behalf of the City all suites for damages, even if groundless, false or fraudulent brought because of such damages. Grantee shall pay all judgments finally establishing liability of the City in actions defended by Grantee pursuant to this section, along with all attorneys’ fees and costs incurred by the City, including interest accruing to the date of payment by Grantee and premiums on any appeal bonds.

The City, at its election, will have the right to participate in any such negotiations or legal proceedings to the extent of its interest. In addition, the Grantee shall promptly advise the City in writing of any claim or demand against the City or the Grantee known to the Grantee related to or arising out of the Grantee’s activities under this License. **The City will not be responsible for any loss of or damage to the Grantee’s property from any cause.**

**SECTION 11. RIGHTS IN THE EVENT OF ABANDONMENT**

As an express condition of this License, and not as a mere covenant, in the event Grantee abandons the outdoor stairway or a portion thereof or ceases to use the outdoor stairway for the purposes enumerated herein for any period of six (6) months or longer, other than the time elapsing between the Effective Date of this license and the completion of construction of the outdoor stairway, this

License shall automatically terminate, free and clear of any right, title, or interest in Grantee without the necessity of any notice to Grantee or any re-entry by the City.

## **SECTION 12. CANCELLATION**

Grantee shall have the option to terminate this License at any time upon giving the City written notice thirty (30) days in advance of such termination. In addition, the City shall have the option to cancel and terminate this License for failure of Grantee to comply with any material provision or requirement contained in this agreement after thirty (30) days written notice to Grantee. However, if said breach or failure to comply cannot be reasonably cured within thirty (30) days, if Grantee shall proceed promptly to cure the same with due diligence, the time for curing such failure to comply shall be extended for such period of time as may be deemed reasonably necessary by the City to complete such curing unless such breach involves public safety.

The City shall have the option to terminate this License at any time upon giving the Grantee written notice thirty (30) days in advance of such termination, at no cost to the City and may take possession of the City right-of-way. All rights of the Grantee for the City right-of-way shall then be terminated. If the License is cancelled by the City, Grantee shall not be entitled to a refund of the paid annual consideration for the months remaining in the License year (the twelve month period beginning on the effective date of this License). If this License is cancelled due to Grantee's failure to cure any default under this License, abandonment or cancellation by Grantee, Grantee shall not be entitled to a refund of consideration paid to the City.

Upon termination of this License, prior to the expiration of the original term for any reason, Grantee shall remove Grantee's outdoor stairway located in the License Area at no cost to the City. Grantee shall restore the License Area to the reasonable satisfaction of the City Engineer and in accordance with City specifications, at Grantee's own cost and expense. Any such restoration shall be subject to the reasonable approval of the City. If the Grantee fails to restore the License Area as required herein, the City may at its option restore the License Area and charge such costs to Grantee who shall be responsible for payment of such repair and restoration costs.



The City shall have the option to terminate this License at any time or assure that the property is maintained in good order throughout the term of the license upon written notice thirty (30) days in advance of such termination, at no cost to the City and may take possession of the City right-of-way. All rights of the Grantee for the City right-of-way shall then be terminated, unless upon termination of this License, the City agrees to the sale of the land to the Grantee, which upon payment of a fair valuation therefore, the land shall be and become the property of the Grantee.

**SECTION 13. RECORDS**

The El Paso City Council and the El Paso City Manager or designee shall be kept fully informed by Grantee as to matters pertaining in any way to Grantee’s exercise of Grantee’s rights under this License, including the construction, replacement, future maintenance, use and repair of the outdoor stairway within the License Area. Obtaining all applicable City permits shall be deemed sufficient to keep such parties informed. Grantee shall keep complete and accurate maps, construction drawings, and specifications describing the location of the structure(s) within the City right-of-way. The City shall have the right, at reasonable times to inspect such maps, construction drawings, and specifications.

**SECTION 14. NOTICE**

Any notice or communication required in the administration of this License shall be sent in writing by prepaid certified mail, return receipt requested, to the following addresses:

CITY: City of El Paso  
Attn: City Manager  
300 North Campbell Street  
El Paso, Texas 79901

with copy to: City of El Paso  
ATTN: Planning and Inspections Department  
811 Texas Avenue  
El Paso, Texas 79901

with copy to: City of El Paso  
ATTN: Financial Services Department –  
Financial Accounting & Reporting  
300 North Campbell Street  
El Paso, Texas 79901

GRANTEE: 1031 Firestone, LLC  
2223 Montana Avenue  
El Paso, Texas 79903

or to such other addresses as Grantee may designate from time to time by written notice as required in this paragraph.

**SECTION 15. ASSIGNMENT**

The rights granted by this License inure to the benefit of the Grantee, and any parent, subsidiary, or successor entity now or hereafter existing. The rights shall not be assignable without the express advanced written consent of the El Paso City Manager.

**SECTION 16. LEASING OR DEDICATION OF FACILITIES**

Grantee, without the advanced written consent of the El Paso City Manager or designee, shall not lease the License Area to any non-grantee person or entity.

**SECTION 17. ADMINISTRATION OF LICENSE**

The El Paso City Manager or designee is the principal City official responsible for the administration of this License. Grantee recognizes that questions regarding the interpretation or application of this License shall be referred to the El Paso City Manager or designee.

**SECTION 18. NO PROPERTY RIGHTS**

Nothing herein shall grant any real property interest to the Grantee nor give rise to any vested right in the Grantee, Grantee's assigns or successors in interest, none of whom shall have a cause of action for damages upon revocation or termination of this License in accordance with the terms

NESV2022-00002

herein.

**SECTION 19. LIENS AND ENCUMBRANCES**

Grantee shall defend and indemnify the City against any liability and loss of any type arising from any lien or encumbrance on the License Area that arises or is alleged to have arisen from Grantee's use of the Licensed Area.

**SECTION 20. RIGHT OF ENTRY AND INSPECTION**

The City's authorized representative shall have the right to enter upon the licensed area at all reasonable times for the purpose of inspecting the same and determining compliance with the terms of this License.

**SECTION 21. LAWS AND ORDINANCES**

Grantee shall comply with all applicable statutes, laws, codes and ordinances applicable to Grantee's construction, repair, renovation, alteration or use of the License Area.

**SECTION 22. ENTIRE AGREEMENT**

This document contains all of the agreements between the parties and may not be modified, except by an agreement in writing signed by both parties.

**SECTION 23. SEVERABILITY**

Every provision of this license is intended to be severable. If any term or provision hereof is illegal or invalid for any reason whatsoever, such illegality shall not affect the validity of the remainder of this license.

**SECTION 24. LAWS GOVERNING/VENUE**

The laws of the State of Texas shall govern the validity, performances, and enforcement of this license and if legal action is necessary to enforce it, exclusive venue shall be in El Paso County, Texas.

**SECTION 25. RESTRICTIONS AND RESERVATIONS**

This License is subject to all rights-of-way, easements, dedications, restrictions, reservations and other encumbrances of record and running with the land. If, at any time during the initial term of this license, or any extension thereof, any such rights-of-way, easements, dedications, restrictions, reservations and other encumbrances of record and running with the land, preclude, interrupt or interfere with Grantee’s use of the License Area, Grantee shall have the right to terminate this License upon giving the City prior written notice of its intent to do so.

**SECTION 26. EFFECTIVE DATE**

The Effective Date of this License shall be the date last entered below. This License shall not take effect unless Grantee files Grantee’s written acceptance with the City prior to the enactment of this License by the El Paso City Council.

**PASSED AND APPROVED** this \_\_\_\_ day of \_\_\_\_\_, 2022

(Signatures begin on the following page)

**WITNESS THE FOLLOWING SIGNATURES AND SEALS**

**THE CITY OF EL PASO:**

---

Oscar Leeser  
Mayor

**ATTEST:**

---

Laura D. Prine  
City Clerk

**APPROVED AS TO FORM:**

*Wendi N. Vineyard*

---

Wendi N. Vineyard  
Assistant City Attorney

**APPROVED AS TO CONTENT:**

*Philip F. Etiwe*

---

Philip F. Etiwe, Director  
Planning and Inspections Department

**ACCEPTANCE**

The above instrument, with all conditions thereof, is here by accepted this 24 day of May, 2022.

**GRANTEE:**

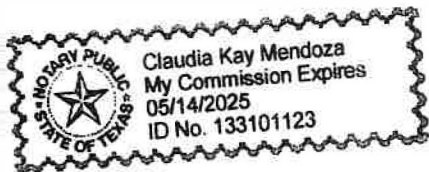
1031 FIRESTONE, LLC.

By: \_\_\_\_\_  
Name: Mike Luccan  
Title: President

**ACKNOWLEDGMENT**

THE STATE OF TEXAS )  
)  
COUNTY OF EL PASO )

This instrument is acknowledged before me on this 24 day of May, 2022, by \_\_\_\_\_ as Grantee.



Claudia Kay Mendoza  
Notary Public, State of Texas  
Claudia Kay Mendoza  
Notary's Printed or Typed Name  
5/14/25  
My Commission Expires

EXHIBIT A

Being a Portion of a 20' Alley, Block 3  
Franklin Heights,  
City of El Paso, El Paso County, Texas  
February 4, 2022

**METES AND BOUNDS DESCRIPTION**  
1025 Texas Avenue  
Exhibit "A"

**FIELD NOTE DESCRIPTION** of a Portion of a 20' Alley, Block 3, Franklin Heights, City of El Paso, El Paso County, Texas, being more particularly described by metes and bounds as follows:


**COMMENCING FOR REFERENCE** at a found city monument 10' offset North of the centerline intersection of Octavia Street (70' R.O.W.) and Texas Avenue (72' R.O.W.); **THENCE**, along said centerline right-of-way of Octavia Street, North 37°37'00" West, a distance of 146.00 feet to a point along said centerline right-of-way line; **THENCE**, leaving said centerline right-of-way, South 52°23'00" West, a distance of 35.00 feet to point at the northeast corner of Lot 32, Block 3, Franklin Heights, same being the common boundary corner of the westerly right-of-way line of Octavia Street (70' R.O.W.) and the southerly right-of-way line of a 20' Alley; **THENCE**, leaving said westerly right-of-way line and along the southerly right-of-way line of a 20' Alley, South 52°23'00" West, a distance of 56.17 feet to the **POINT OF BEGINNING** of the herein described parcel;

**THENCE**, along said westerly right-of-way line of a 20' Alley, South 52°23'00" West, a distance of 45.00 feet to a point for corner along said westerly right-of-way line;

**THENCE**, leaving said westerly right-of-way line, North 37°37'00" West, a distance of 5.00 feet to a point for corner;

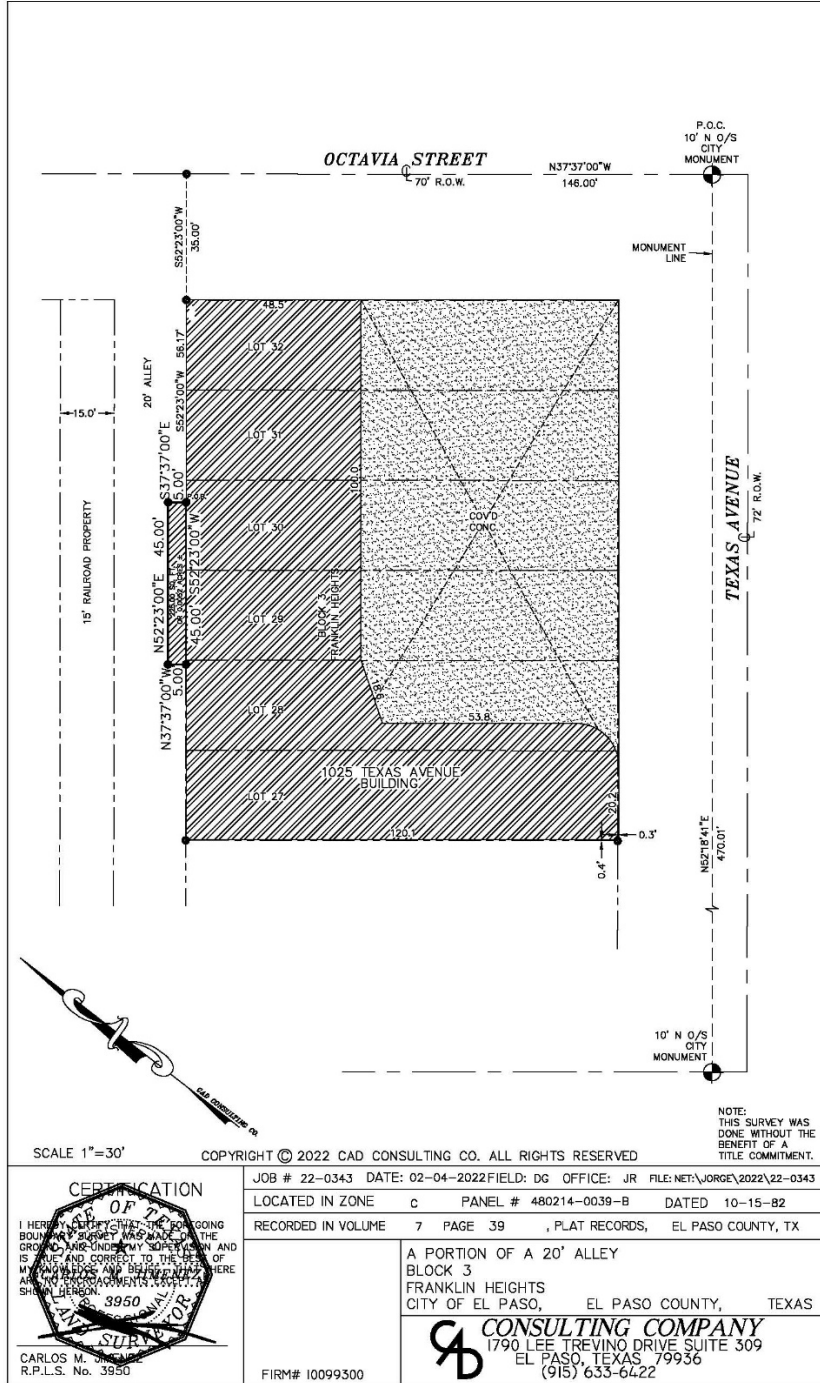
**THENCE**, North 52°23'00" East, a distance of 45.00 feet to a point for corner;

**THENCE**, South 37°37'00" East, a distance of 5.00 feet to the **POINT OF BEGINNING** of the herein described parcel and containing 225.00 square feet or 0.0052 acres of land more or less.

  
CAD Consulting Co.  
1790 Lee Trevino Drive, Suite 309  
El Paso, Texas 79936  
(915) 633-6422  
I:\M&B\2021\21-2435\_1025 Texas (stairs)

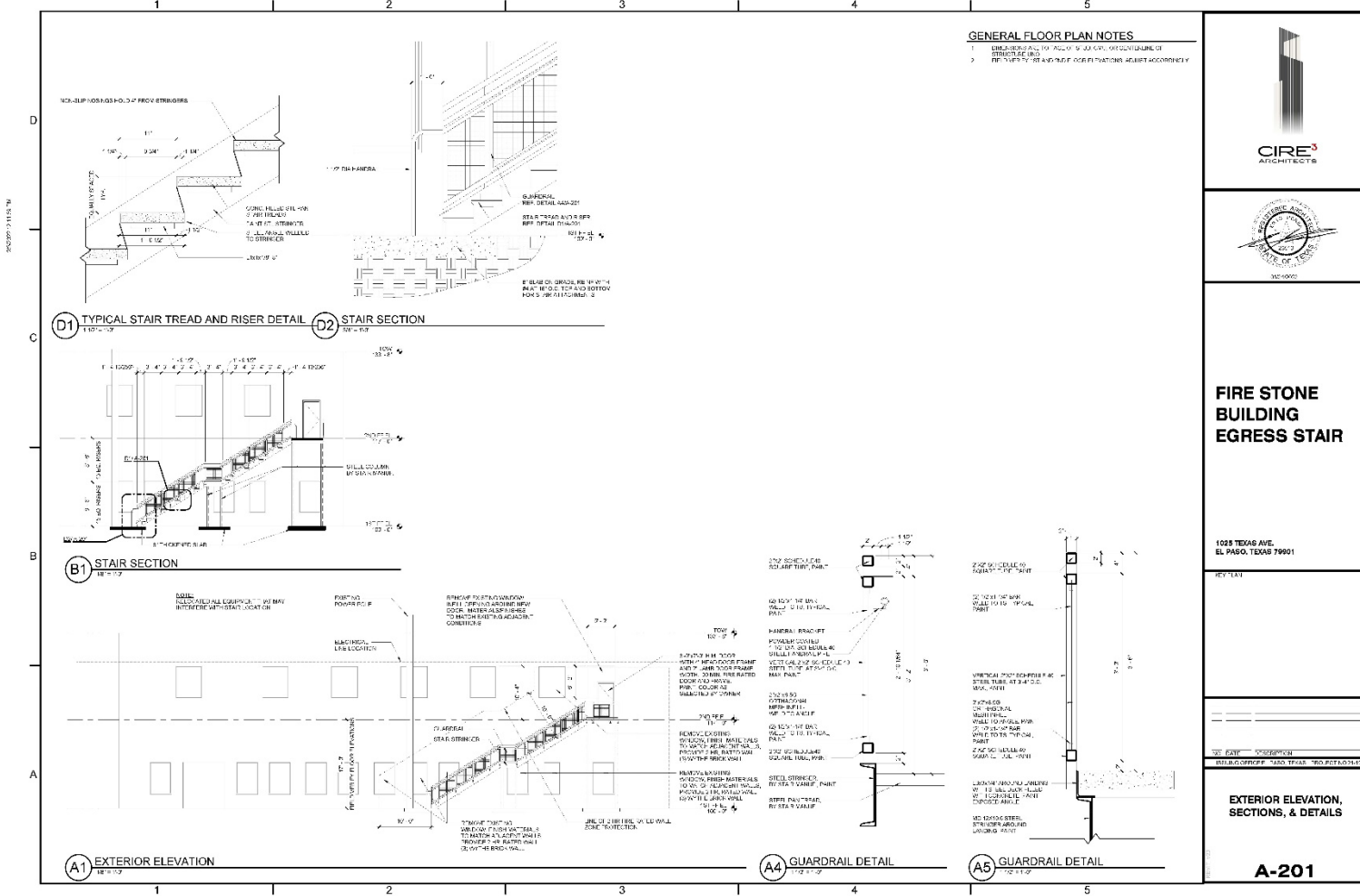


EXHIBITS B



JOB # 22-0343 DATE: 02-04-2022 FIELD: DG OFFICE: JR FILE: NET:\JORGE\2022\22-0343	
LOCATED IN ZONE	C PANEL # 480214-0039-B DATED 10-15-82
RECORDED IN VOLUME	7 PAGE 39 PLAT RECORDS, EL PASO COUNTY, TX
A PORTION OF A 20' ALLEY BLOCK 3 FRANKLIN HEIGHTS CITY OF EL PASO, EL PASO COUNTY, TEXAS	
<b>CONSULTING COMPANY</b> 1790 LEE TREVINO DRIVE SUITE 309 EL PASO, TEXAS 79936 (915) 633-6422	
FIRM#	10099300





**FIRE STONE BUILDING EGRESS STAIR**

1025 TEXAS AVE.  
EL PASO, TEXAS 79901

DATE: 05/11/2022  
DRAWN: C. ROBERTSON

NESV2022-00002

22-1007-2903 | 1170627  
NESV22-00002 1031 Firestone | Ordinance  
WNV



Legislation Text

---

File #: 22-861, Version: 1

---

**CITY OF EL PASO, TEXAS  
LEGISTAR AGENDA ITEM SUMMARY FORM**

**DISTRICT, DEPARTMENT, CONTACT INFORMATION:**

*Please choose District and Department from drop down menu. Please post exactly as example below.  
No Title's, No emails. Please use ARIAL 10 Font.*

**Districts 2 and 4**

Streets and Maintenance, Randy Garcia, (915) 212-7005

**AGENDA LANGUAGE:**

*This is the language that will be posted to the agenda. Please use ARIAL 11 Font.*

An Ordinance amending Title 12 (Vehicles and Traffic), Chapter 12.88 (Schedules), Section 12.88.150 (Schedule XIV-Speed Limits), to amend paragraph N (Speed limits on the following of Pershing Drive and Dyer Street) subparagraph 2; and to amend by deleting paragraph N-(Speed limits on the following of Pershing Drive and Dyer Street) subparagraph 3, to amend by deleting paragraph N (Speed limits on the following of Pershing Drive and Dyer Street) subparagraph 4; and to amend by deleting paragraph N (Speed limits on the following of Pershing Drive and Dyer street) subparagraph 5; the penalty being provided in Chapter 12.84 of the El Paso City Code.

**CITY OF EL PASO, TEXAS  
AGENDA ITEM  
DEPARTMENT HEAD'S SUMMARY FORM**

**INTRODUCTION DATE:** July 19, 2022  
**PUBLIC HEARING DATE:** August 2, 2022

**CONTACT PERSON(S) NAME AND PHONE NUMBER:** Randy Garcia, 915-212-7005

**DISTRICT(S) AFFECTED:** 2 & 4

**STRATEGIC GOAL:** 7 – Enhance and Sustain El Paso's Infrastructure Network

**SUBGOAL:** 7.3 – Enhance a regional comprehensive transportation system

**SUBJECT:**

An ordinance amending Title 12 (Vehicles and Traffic), Chapter 12.88 (Schedules), Section 12.88.150 (Schedule XIV-Speed Limits), to amend paragraph N (Speed limits on the following of Pershing Drive and Dyer Street) subparagraph 2; and to amend by deleting paragraph N (Speed limits on the following of Pershing Drive and Dyer Street) subparagraph 3, to amend by deleting paragraph N (Speed limits on the following of Pershing Drive and Dyer Street) subparagraph 4; and to amend by deleting paragraph N (Speed limits on the following of Pershing Drive and Dyer street) subparagraph 5; the penalty being provided in Chapter 12.84 of the El Paso City Code.

**BACKGROUND / DISCUSSION:**

To set a single uniform speed limit, of 40 M.P.H. on Dyer St. from Pershing Dr. to Quail Ave. based on recommendations from a speed study completed by TxDOT. This will allow the City to coordinate future pedestrian HAWK signal installation with EPISD and TxDOT for Chapin High School.

**PRIOR COUNCIL ACTION:**

N/A

**AMOUNT AND SOURCE OF FUNDING:**

**HAVE ALL AFFECTED DEPARTMENTS BEEN NOTIFIED?**  YES  NO

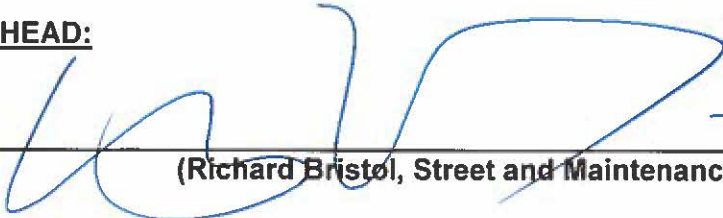
**PRIMARY DEPARTMENT:** Streets and Maintenance

**SECONDARY DEPARTMENT:** N/A

---

\*\*\*\*\*REQUIRED AUTHORIZATION\*\*\*\*\*

**DEPARTMENT HEAD:**

  
7-8-22  
\_\_\_\_\_  
(Richard Bristol, Street and Maintenance Director)

ORDINANCE NO. \_\_\_\_\_

**AN ORDINANCE AMENDING TITLE 12 (VEHICLES AND TRAFFIC), CHAPTER 12.88 (SCHEDULES), SECTION 12.88.150 (SCHEDULE XIV-SPEED LIMITS), TO AMEND PARAGRAPH N (SPEED LIMITS ON THE FOLLOWING OF PERSHING DRIVE AND DYER STREET) SUBPARAGRAPH 2; AND TO AMEND BY DELETING PARAGRAPH N (SPEED LIMITS ON THE FOLLOWING OF PERSHING DRIVE AND DYER STREET) SUBPARAGRAPH 3, TO AMEND BY DELETING PARAGRAPH N (SPEED LIMITS ON THE FOLLOWING OF PERSHING DRIVE AND DYER STREET) SUBPARAGRAPH 4; AND TO AMEND BY DELETING PARAGRAPH N (SPEED LIMITS ON THE FOLLOWING OF PERSHING DRIVE AND DYER STREET) SUBPARAGRAPH 5; THE PENALTY BEING PROVIDED IN CHAPTER 12.84 OF THE EL PASO CITY CODE.**

**NOW, THEREFORE, BE IT ORDAINED BY THE CITY COUNCIL OF THE CITY OF EL PASO:**

**SECTION 1.** That Title 12 (Vehicles and Traffic), Chapter 12.88 (Schedules), Section 12.88.150 (Schedule XIV-Speed limits), Paragraph N (Speed limits on the following parts of Pershing Drive and Dyer Street :), Subparagraph 2, be amended to read as follows:

2. 40 m.p.h. on Dyer Street from Pershing Drive to Quail Avenue

**SECTION 2.** Delete Title 12 (Vehicles and Traffic), Chapter 12.88 (Schedules), Section 12.88.150 (Schedule XIV-Speed limits), Paragraph N (Speed limits on the following parts of Pershing Drive and Dyer Street), Subparagraph 3, be amended to read as follows:

3. 45 m.p.h. on Dyer Street from Kemp Avenue to Gateway South

**SECTION 3.** Delete Title 12 (Vehicles and Traffic), Chapter 12.88 (Schedules), Section 12.88.150 (Schedule XIV-Speed limits), Paragraph N (Speed limits on the following parts of Pershing Drive and Dyer Street), Subparagraph 4, be amended to read as follows:

4. 40 m.p.h. on Dyer Street from Gateway South Boulevard to a point 500 feet north of Rushing Boulevard to Quail Avenue

**SECTION 4.** Delete Title 12 (Vehicles and Traffic), Chapter 12.88 (Schedules), Section 12.88.150 (Schedule XIV-Speed limits), Paragraph N (Speed limits on the following parts of Pershing Drive and Dyer Street), Subparagraph 5, be amended to read as follows:

5. 45 m.p.h. on Dyer Street from a point 500 feet north of Rushing Boulevard to Quail Avenue

**SECTION 5.** Except as herein amended, Title 12 of the El Paso City Code shall remain in full force and effect.

ADOPTED this \_\_\_\_ day of \_\_\_\_\_, 2022.


**CITY OF EL PASO**

\_\_\_\_\_  
Oscar Leeser, Mayor

**ATTEST:**

\_\_\_\_\_  
Laura D. Princ City Clerk

**APPROVED AS TO FORM:**

  
\_\_\_\_\_  
Evy A Sotelo  
Assistant City Attorney

**APPROVED AS TO CONTENT:**

  
\_\_\_\_\_  
Richard Bristol, Director  
Streets & Maintenance Department



# Ordinance Amending Title 12.88.150

*Amend ordinance to decrease speed limit on  
portions of Dyer Street*

District(s): 2 & 4

Introduction: July 19, 2022

Public Hearing: August 2, 2022



# Strategic Plan

Goal 7: Enhance and Sustain El Paso's Infrastructure Network

7.3 – Enhance regional comprehensive transportation system

---

# Purpose of Amendment

Decrease the speed limit from 45 MPH to 40 MPH on portions of Dyer St as recommended by TxDOT.

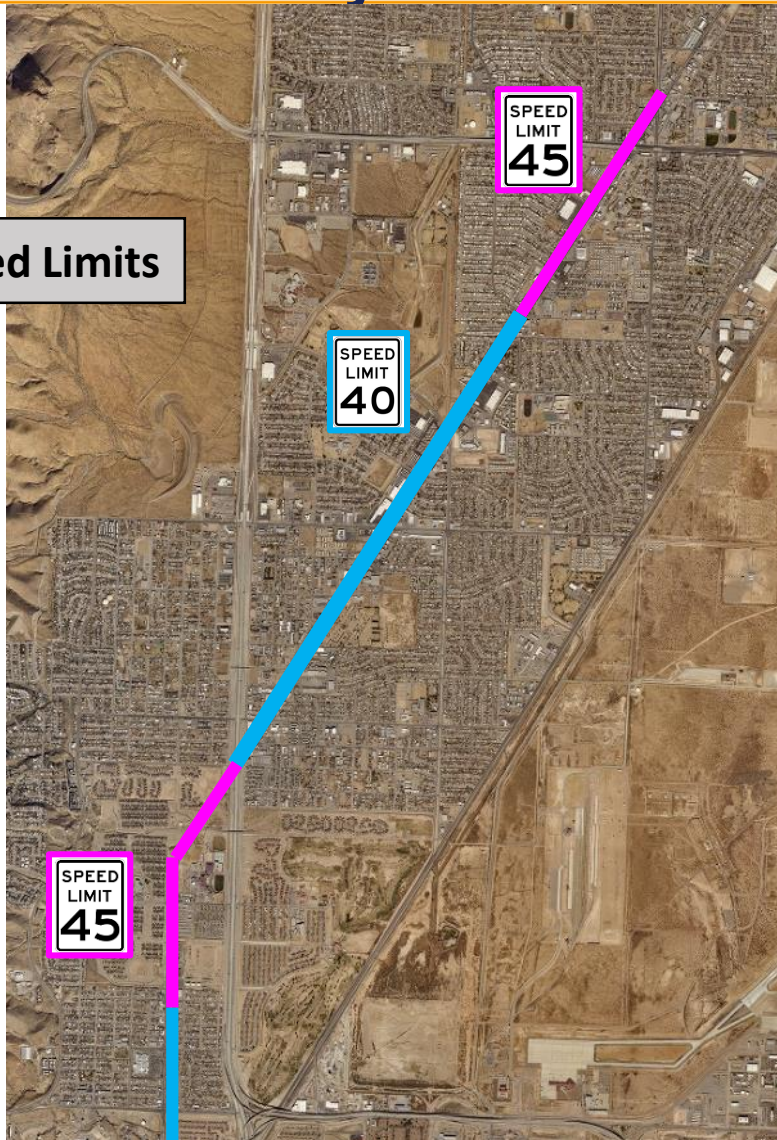
- TxDOT ROW
  - TxDOT performed speed study
  - 40 MPH recommended
  - Increase in developments and driveways
- **PROPOSED** - Installation of new School Zone for Chapin High School
  - Agreement pending – EPISD, TxDOT & City of El Paso
  - Construction of HAWK Pedestrian System
  - Construction of Mid Block crossing
- Uniform speed limit on Dyer ST from Quail Ave to Pershing Dr. specified by Ordinance Amendment of Title 12.88.150



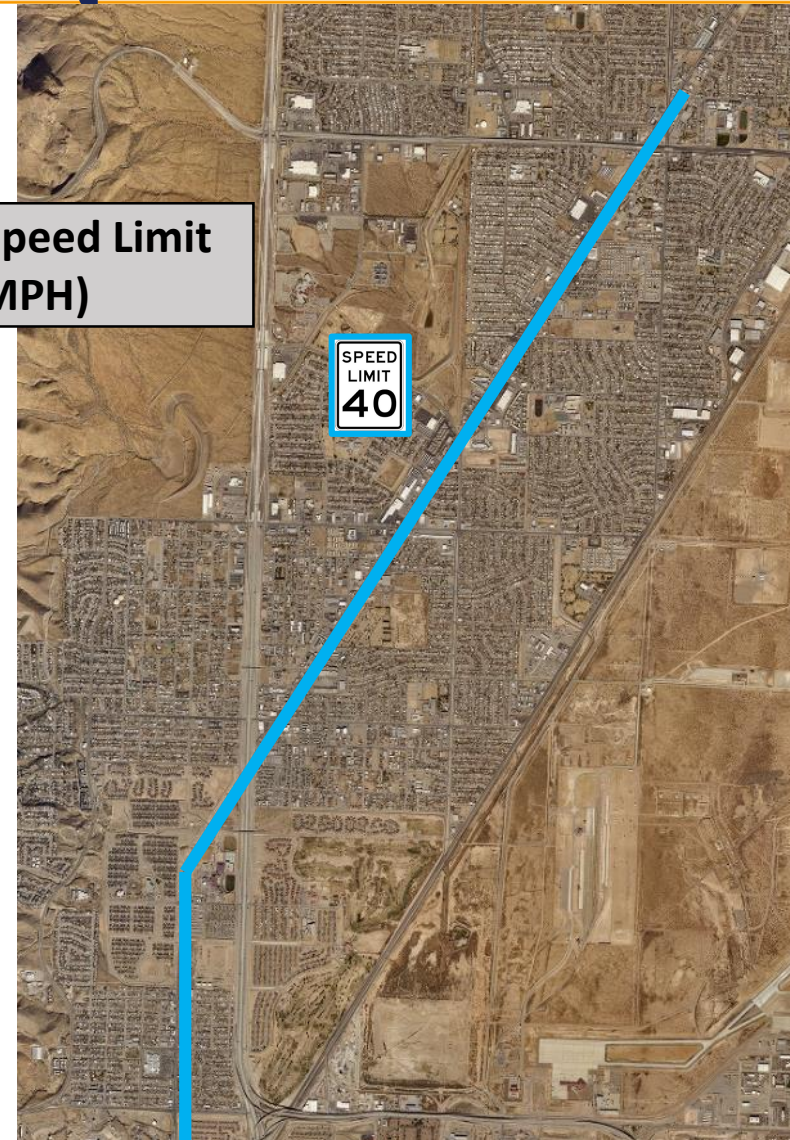


# Dyer St. from Kemp Ave to Quail Ave

Existing Speed Limits



Proposed Speed Limit  
(40 MPH)





# Dyer St. from Kemp Ave to Gateway South



**Proposed Speed Limit  
(40 MPH)**

# Dyer St. from Rushing Blvd to Quail Ave





# Requested Council Action

---



**AN ORDINANCE AMENDING TITLE 12 (VEHICLES AND TRAFFIC), CHAPTER 12.88 (SCHEDULES), SECTION 12.88.150 (SCHEDULE XIV-SPEED LIMITS), TO AMEND PARAGRAPH N (SPEED LIMITS ON THE FOLLOWING OF PERSHING DRIVE AND DYER STREET) SUBPARAGRAPH 2; AND TO AMEND BY DELETING PARAGRAPH N (SPEED LIMITS ON THE FOLLOWING OF PERSHING DRIVE AND DYER STREET) SUBPARAGRAPH 3, TO AMEND BY DELETING PARAGRAPH N (SPEED LIMITS ON THE FOLLOWING OF PERSHING DRIVE AND DYER STREET) SUBPARAGRAPH 4; AND TO AMEND BY DELETING PARAGRAPH N (SPEED LIMITS ON THE FOLLOWING OF PERSHING DRIVE AND DYER STREET) SUBPARAGRAPH 5; THE PENALTY BEING PROVIDED IN CHAPTER 12.84 OF THE EL PASO CITY CODE.**

**NOW, THEREFORE, BE IT ORDAINED BY THE CITY COUNCIL OF THE CITY OF EL PASO:**

- **SECTION 1.** That Title 12 (Vehicles and Traffic), Chapter 12.88 (Schedules), Section 12.88.150 (Schedule XIV-Speed limits), Paragraph N (Speed limits on the following parts of Pershing Drive and Dyer Street :), Subparagraph 2, be amended to read as follows:
  - 2. 40 m.p.h. on Dyer Street from Pershing Drive to Quail Avenue



# Requested Council Action

---



Continued

- **SECTION 2.** Delete Title 12 (Vehicles and Traffic), Chapter 12.88 (Schedules), Section 12.88.150 (Schedule XIV-Speed limits), Paragraph N (Speed limits on the following parts of Pershing Drive and Dyer Street), Subparagraph 3, be amended to read as follows:
  - 3. 45 m.p.h. on Dyer Street from Kemp Avenue to Gateway South
- **SECTION 3.** Delete Title 12 (Vehicles and Traffic), Chapter 12.88 (Schedules), Section 12.88.150 (Schedule XIV-Speed limits), Paragraph N (Speed limits on the following parts of Pershing Drive and Dyer Street), Subparagraph 4, be amended to read as follows:
  - 4. 40 m.p.h. on Dyer Street from Gateway South Boulevard to a point 500 feet north of Rushing Boulevard to Quail Avenue



# Requested Council Action

---



Continued

- **SECTION 4.** Delete Title 12 (Vehicles and Traffic), Chapter 12.88 (Schedules), Section 12.88.150 (Schedule XIV-Speed limits), Paragraph N (Speed limits on the following parts of Pershing Drive and Dyer Street), Subparagraph 5, be amended to read as follows:
  - 5. 45 m.p.h. on Dyer Street from a point 500 feet north of Rushing Boulevard to Quail Avenue
- **SECTION 5.** Except as herein amended, Title 12 of the El Paso City Code shall remain in full force and effect.





## Mission

Deliver exceptional services to support a high quality of life and place for our community



## Values

Integrity, **R**espect, **E**xcellence,  
**A**ccountability, **P**eople



## Vision

Develop a vibrant regional economy, safe and beautiful neighborhoods and exceptional recreational, cultural and educational opportunities powered by a high performing government



## Misión

Brindar servicios excepcionales para respaldar una vida y un lugar de alta calidad para nuestra comunidad

## Valores

Integridad, **R**espeto, **E**xcelencia, **R**esponsabilidad, **P**ersonas

## Visión

Desarrollar una economía regional vibrante, vecindarios seguros y hermosos y oportunidades recreativas, culturales y educativas excepcionales impulsadas por un gobierno de alto desempeño





# Ordinance Amending Title 12.88.150

*Amend ordinance to decrease speed limit on  
portions of Dyer Street*

District(s): 2 & 4

Introduction: July 19, 2022

Public Hearing: August 2, 2022





# Strategic Plan

Goal 7: Enhance and Sustain El Paso's Infrastructure Network

7.3 – Enhance regional comprehensive transportation system

# Purpose of Amendment

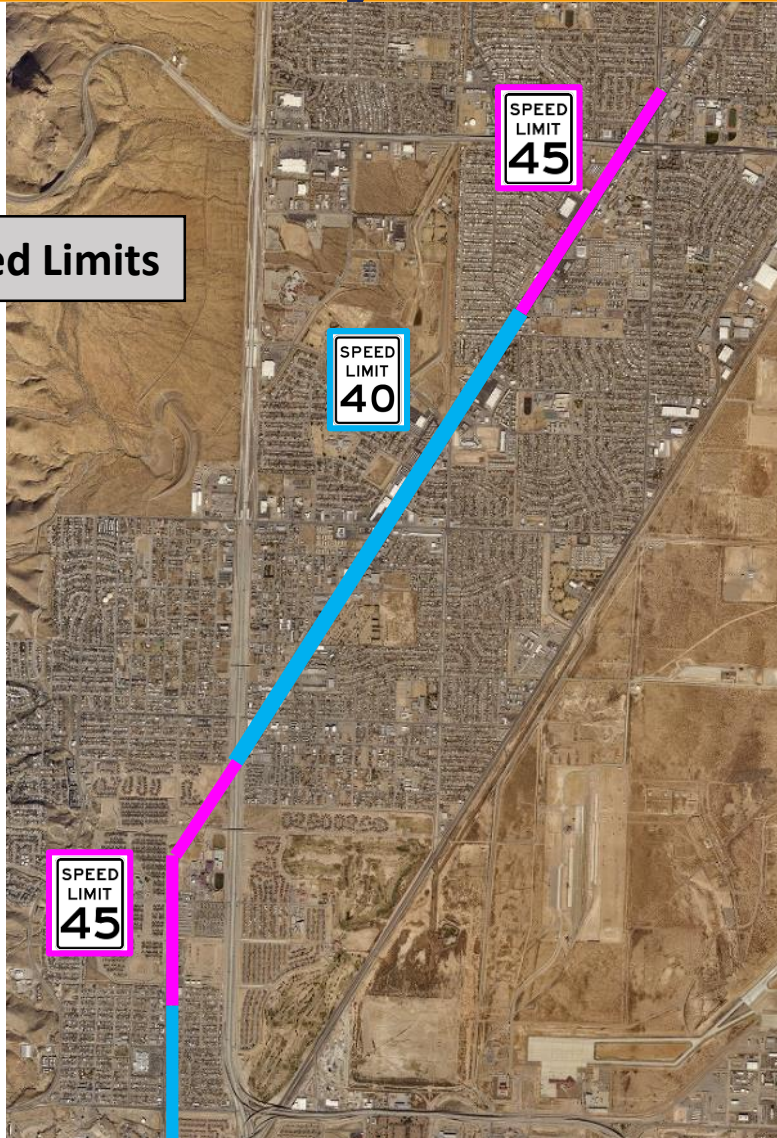
Decrease the speed limit from 45 MPH to 40 MPH on portions of Dyer St as recommended by TxDOT.

- TxDOT ROW
  - TxDOT performed speed study
  - 40 MPH recommended
  - Increase in developments and driveways
- **PROPOSED** - Installation of new School Zone for Chapin High School
  - Agreement pending – EPISD, TxDOT & City of El Paso
  - Construction of HAWK Pedestrian System
  - Construction of Mid Block crossing
- Uniform speed limit on Dyer ST from Quail Ave to Pershing Dr. specified by Ordinance Amendment of Title 12.88.150

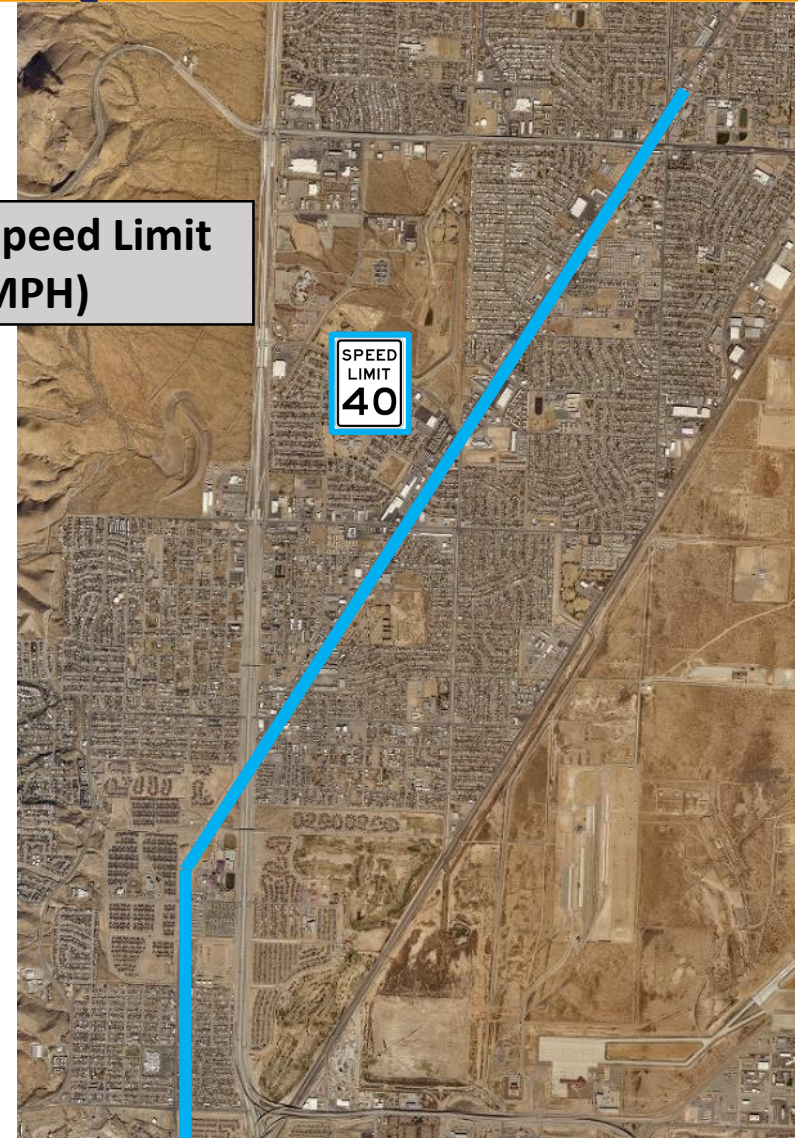


# Dyer St. from Kemp Ave to Quail Ave

Existing Speed Limits



Proposed Speed Limit  
(40 MPH)





# Dyer St. from Kemp Ave to Gateway South



**Proposed Speed Limit  
(40 MPH)**

# Dyer St. from Rushing Blvd to Quail Ave





# Requested Council Action

---



**AN ORDINANCE AMENDING TITLE 12 (VEHICLES AND TRAFFIC), CHAPTER 12.88 (SCHEDULES), SECTION 12.88.150 (SCHEDULE XIV-SPEED LIMITS), TO AMEND PARAGRAPH N (SPEED LIMITS ON THE FOLLOWING OF PERSHING DRIVE AND DYER STREET) SUBPARAGRAPH 2; AND TO AMEND BY DELETING PARAGRAPH N (SPEED LIMITS ON THE FOLLOWING OF PERSHING DRIVE AND DYER STREET) SUBPARAGRAPH 3, TO AMEND BY DELETING PARAGRAPH N (SPEED LIMITS ON THE FOLLOWING OF PERSHING DRIVE AND DYER STREET) SUBPARAGRAPH 4; AND TO AMEND BY DELETING PARAGRAPH N (SPEED LIMITS ON THE FOLLOWING OF PERSHING DRIVE AND DYER STREET) SUBPARAGRAPH 5; THE PENALTY BEING PROVIDED IN CHAPTER 12.84 OF THE EL PASO CITY CODE.**

**NOW, THEREFORE, BE IT ORDAINED BY THE CITY COUNCIL OF THE CITY OF EL PASO:**

- **SECTION 1.** That Title 12 (Vehicles and Traffic), Chapter 12.88 (Schedules), Section 12.88.150 (Schedule XIV-Speed limits), Paragraph N (Speed limits on the following parts of Pershing Drive and Dyer Street :), Subparagraph 2, be amended to read as follows:
  - 2. 40 m.p.h. on Dyer Street from Pershing Drive to Quail Avenue



# Requested Council Action

---



Continued

- **SECTION 2.** Delete Title 12 (Vehicles and Traffic), Chapter 12.88 (Schedules), Section 12.88.150 (Schedule XIV-Speed limits), Paragraph N (Speed limits on the following parts of Pershing Drive and Dyer Street), Subparagraph 3, be amended to read as follows:
  - 3. 45 m.p.h. on Dyer Street from Kemp Avenue to Gateway South
- **SECTION 3.** Delete Title 12 (Vehicles and Traffic), Chapter 12.88 (Schedules), Section 12.88.150 (Schedule XIV-Speed limits), Paragraph N (Speed limits on the following parts of Pershing Drive and Dyer Street), Subparagraph 4, be amended to read as follows:
  - 4. 40 m.p.h. on Dyer Street from Gateway South Boulevard to a point 500 feet north of Rushing Boulevard to Quail Avenue



# Requested Council Action

---



Continued

- **SECTION 4.** Delete Title 12 (Vehicles and Traffic), Chapter 12.88 (Schedules), Section 12.88.150 (Schedule XIV-Speed limits), Paragraph N (Speed limits on the following parts of Pershing Drive and Dyer Street), Subparagraph 5, be amended to read as follows:
  - 5. 45 m.p.h. on Dyer Street from a point 500 feet north of Rushing Boulevard to Quail Avenue
- **SECTION 5.** Except as herein amended, Title 12 of the El Paso City Code shall remain in full force and effect.





## Mission

Deliver exceptional services to support a high quality of life and place for our community



## Values

Integrity, **R**espect, **E**xcellence,  
**A**ccountability, **P**eople



## Vision

Develop a vibrant regional economy, safe and beautiful neighborhoods and exceptional recreational, cultural and educational opportunities powered by a high performing government





## Misión

Brindar servicios excepcionales para respaldar una vida y un lugar de alta calidad para nuestra comunidad

## Valores

Integridad, **R**espeto, **E**xcelencia, **R**esponsabilidad, **P**ersonas

## Visión

Desarrollar una economía regional vibrante, vecindarios seguros y hermosos y oportunidades recreativas, culturales y educativas excepcionales impulsadas por un gobierno de alto desempeño





Legislation Text

---

**File #: 22-972, Version: 1**

---

**CITY OF EL PASO, TEXAS  
LEGISTAR AGENDA ITEM SUMMARY FORM**

**DISTRICT, DEPARTMENT, CONTACT INFORMATION:**

*Please choose District and Department from drop down menu. Please post exactly as example below.  
No Title's, No emails. Please use ARIAL 10 Font.*

**All Districts**

Airport, Sam Rodriguez, (915) 212-7301

**AGENDA LANGUAGE:**

*This is the language that will be posted to the agenda. Please use ARIAL 11 Font.*

Discussion and action on the approval of a Resolution to authorize the Director of Aviation to sign and submit a grant application and related documentation to the Federal Aviation Administration (FAA) and be designated the official representative of the City of El Paso to act in connection with the application process for the Airport Improvement Program (AIP) Project No. 3-48-0077-047-2022. That upon approval and issuance of such grant by the FAA, the City Manager be authorized to accept and sign the grant agreement, any related grant modifications, and other necessary documents when the form and substance of those documents has been reviewed and approved by the City Attorney's Office, and that such authorization will include the ability to accept and sign multiple agreements and documents, as the FAA grant may be issued in various disbursements. That the City Manager be authorized to approve and sign any budget transfers needed to establish appropriations in connection with this grant. The total grant amount shall include a federal estimated share of \$13,070,029 and an estimated match of \$2,002,565 to be paid for with Airport Enterprise Funds, totaling \$15,072,594 for the following projects: RWY 8R-26L & Connecting Taxiways Rehabilitation, and RWY 8R-26L Reconstruction - Taxiway U from Customs Ramp to TWY V Reconstruction.

**CITY OF EL PASO, TEXAS  
AGENDA ITEM  
DEPARTMENT HEAD'S SUMMARY FORM**

**DEPARTMENT:** Aviation  
**AGENDA DATE:** August 2, 2022  
**CONTACT PERSON/PHONE:** Sam Rodriguez, PE – Director of Aviation – 212-7301  
**DISTRICT(S) AFFECTED:** All  
**STRATEGIC GOALS:** No. 1: Create an Environment Conducive to Strong, Sustainable Economic Development

**SUBJECT:**

Approval of a resolution to authorize the Director of Aviation to sign and submit a grant application and related documentation to the Federal Aviation Administration (FAA) and be designated the official representative of the City of El Paso to act in connection with the application process for the Airport Improvement Program (AIP) Project No. 3-48-0077-047-2022. That upon approval and issuance of such grant by the FAA, the City Manager be authorized to accept and sign the grant agreement, any related grant modifications, and other necessary documents when the form and substance of those documents has been reviewed and approved by the City Attorney's Office, and that such authorization will include the ability to accept and sign multiple agreements and documents, as the FAA grant may be issued in various disbursements. That the City Manager be authorized to approve and sign any budget transfers needed to establish appropriations in connection with this grant. The total grant amount shall include a federal estimated share of \$13,070,029 and an estimated match of \$2,002,565 to be paid for with Airport Enterprise Funds, totaling \$15,072,594 for the following projects: RWY 8R-26L & Connecting Taxiways Rehabilitation, and RWY 8R-26L Reconstruction - Taxiway U from Customs Ramp to TWY V Reconstruction.

**BACKGROUND / DISCUSSION:**

The Department of Aviation is submitting this FAA grant application for FY2022 entitlements and discretionary funding for the following projects:

- RWY 8R-26L & Connecting Taxiways Rehabilitation
- RWY 8R-26L Reconstruction - Taxiway U from Customs Ramp to TWY V Reconstruction

This specific grant application will be in the amount of \$13,070,029 with a match of \$2,002,565, to be paid for with Airport Enterprise Funds.

Project	AIP Entitlement (Grant 47)	AIP Discretionary (Grant 47)	Airport Enterprise Funds	Total Project Cost
RWY 8R-26L & Connecting Taxiways Rehabilitation	\$5,170,029	\$4,285,772	\$1,050,645	\$10,506,446
RWY 8R-26L Reconstruction - Taxiway U from Customs Ramp to TWY V Reconstruction	\$0	\$3,614,228	\$951,920	\$4,566,148
<b>Total</b>	<b>\$5,170,029</b>	<b>\$7,900,000</b>	<b>\$2,002,565</b>	<b>\$15,072,594</b>

**PRIOR COUNCIL ACTION:**

N/A

**AMOUNT AND SOURCE OF FUNDING:**

FAA Airport Improvement Program Grants - \$5,170,029  
FAA Airport Improvement Program Discretionary - \$7,900,000  
Airport Enterprise Funds - \$2,002,565


**BOARD / COMMISSION ACTION:**

N/A

\*\*\*\*\*REQUIRED AUTHORIZATION\*\*\*\*\*

**LEGAL:** (if required) \_\_\_\_\_ **FINANCE:** (if required) \_\_\_\_\_

**DEPARTMENT HEAD:**

 *for Sam Rodriguez*  
(Example: if RCA is initiated by Purchasing, client department should sign also)  
*Information copy to appropriate Deputy City Manager*

**APPROVED FOR AGENDA:**

**CITY MANAGER:** \_\_\_\_\_

**DATE:** \_\_\_\_\_

# RESOLUTION

## BE IT RESOLVED BY THE CITY COUNCIL OF THE CITY OF EL PASO:

That the Director of Aviation be authorized to sign and submit a grant application and related documentation to the Federal Aviation Administration (FAA) and be designated the official representative of the City of El Paso to act in connection with the application process for the Airport Improvement Program (AIP) Project No. 3-48-0077-047-2022;

That upon approval and issuance of such grant by the FAA, the City Manager be authorized to accept and sign the grant agreement, any related grant modifications, and other necessary documents when the form and substance of those documents have been reviewed and approved by the City Attorney's Office, and that such authorization will include the ability to accept and sign multiple agreements and documents, as the FAA grant may be issued in various disbursements;

That the City Manager be authorized to approve and sign any budget transfers needed to establish appropriations in connection with this grant.

The total grant amount shall include a federal estimated share of \$13,070,029 and an estimated match of \$2,002,565 to be paid for with Airport Enterprise Funds, totaling \$15,072,594 for the following projects:

- RWY 8R-26L & Connecting Taxiways Rehabilitation
- RWY 8R-26L Reconstruction - Taxiway U from Customs Ramp to TWY V Reconstruction.

PASSED AND APPROVED THIS \_\_\_\_ DAY OF \_\_\_\_\_, 2022.

### CITY OF EL PASO

**ATTEST:**

\_\_\_\_\_  
Oscar Leaser, Mayor

\_\_\_\_\_  
Laura D. Prine, City Clerk

**APPROVED AS TO FORM:**

*L. B. Jean-Pierre* (for)  
\_\_\_\_\_  
Leslie B. Jean-Pierre  
Assistant City Attorney

**APPROVED AS TO CONTENT:**

*S. Rodriguez* *for*  
\_\_\_\_\_  
Samuel Rodriguez, P.E.  
Director of Aviation



El Paso, TX

300 N. Campbell  
El Paso, TX

Legislation Text

---

**File #: 22-978, Version: 1**

---

**CITY OF EL PASO, TEXAS  
LEGISTAR AGENDA ITEM SUMMARY FORM**

**DISTRICT, DEPARTMENT, CONTACT INFORMATION:**

*Please choose District and Department from drop down menu. Please post exactly as example below.*

*No Title's, No emails. Please use ARIAL 10 Font.*

City Attorney's Office, Kristen Hamilton-Karam, (915) 212-0033

**AGENDA LANGUAGE:**

*This is the language that will be posted to the agenda. Please use ARIAL 11 Font.*

Consultation with attorney regarding a petition for charter amendments. Matter No. 22-1065-153 (551.071)



El Paso, TX

300 N. Campbell  
El Paso, TX

Legislation Text

---

**File #: 22-977, Version: 1**

---

**CITY OF EL PASO, TEXAS  
LEGISTAR AGENDA ITEM SUMMARY FORM**

**DISTRICT, DEPARTMENT, CONTACT INFORMATION:**

*Please choose District and Department from drop down menu. Please post exactly as example below.*

*No Title's, No emails. Please use ARIAL 10 Font.*

City Attorney's Office, Mathew Engelbaum, (915) 212-0033

**AGENDA LANGUAGE:**

*This is the language that will be posted to the agenda. Please use ARIAL 11 Font.*

Rubio, Arturo vs. City of El Paso; Cause No. 2021DCV2074. Matter No. 21-1036-3478 (551.071)



El Paso, TX

300 N. Campbell  
El Paso, TX

Legislation Text

---

**File #: 22-979, Version: 1**

---

**CITY OF EL PASO, TEXAS  
LEGISTAR AGENDA ITEM SUMMARY FORM**

**DISTRICT, DEPARTMENT, CONTACT INFORMATION:**

*Please choose District and Department from drop down menu. Please post exactly as example below.*

*No Title's, No emails. Please use ARIAL 10 Font.*

City Attorney's Office, Donald Davie, (915) 212-0033

**AGENDA LANGUAGE:**

*This is the language that will be posted to the agenda. Please use ARIAL 11 Font.*

Application of El Paso Electric Company to Change Rates to Open Access Transmission Tariff, Federal Energy Regulatory Commission (FERC); Docket No. ER22-282-000. Matter No. 21-1008-183 (551.071)





El Paso, TX

300 N. Campbell  
El Paso, TX

Legislation Text

---

**File #: 22-980, Version: 1**

---

**CITY OF EL PASO, TEXAS  
LEGISTAR AGENDA ITEM SUMMARY FORM**

**DISTRICT, DEPARTMENT, CONTACT INFORMATION:**

*Please choose District and Department from drop down menu. Please post exactly as example below.*

*No Title's, No emails. Please use ARIAL 10 Font.*

City Attorney's Office, Donald Davie, (915) 212-0033

**AGENDA LANGUAGE:**

*This is the language that will be posted to the agenda. Please use ARIAL 11 Font.*

Application for Approval of Advanced Metering System (AMS) Deployment Plan, AMS Surcharge, and Non-Standard Metering Service Fees, Public Utility Commission of Texas Docket No. 52040. Matter No 21-1008-168 (551.071)



El Paso, TX

300 N. Campbell  
El Paso, TX

Legislation Text

---

**File #: 22-983, Version: 1**

---

**CITY OF EL PASO, TEXAS  
LEGISTAR AGENDA ITEM SUMMARY FORM**

**DISTRICT, DEPARTMENT, CONTACT INFORMATION:**

*Please choose District and Department from drop down menu. Please post exactly as example below.*

*No Title's, No emails. Please use ARIAL 10 Font.*

Economic and International Development, Karina Brasgalla, (915) 212-1570

**AGENDA LANGUAGE:**

*This is the language that will be posted to the agenda. Please use ARIAL 11 Font.*

Purchase, lease, exchange of real property located in El Paso, Texas. Matter No. 22-1004-1402 (551.072)